

STABILITY DEFINED



Sri Lanka Insurance
Corporation Ltd

ANNUAL REPORT 2014







STABILITY DEFINED

Sri Lanka Insurance Corporation Ltd.
Annual Report 2014



Sri Lanka Insurance
Corporation Ltd

GSARN[®] Global Standard Annual Report Number[®]
LKA8532SLICX0140000E155
www.gsarn.org



This Annual Report is Carbon Neutral

This Sri Lanka Insurance Corporation Ltd. annual report has been produced by Smart Media The Annual Report Company, a certified carbon neutral organisation. Additionally, the greenhouse gas emissions resulting from activities outsourced by Smart Media in the production of this annual report, including the usage of paper and printing, are offset through verified sources.



The
ANNUAL REPORT
Company

www.smart.lk



www.carbonfund.org

STABILITY DEFINED

When one has an unblemished history of over 53 years of successful enterprise, providing premium insurance products and services to people across the Nation; when one can claim leadership in the field through aspects such as market share and the largest asset base and life fund amongst all insurers in the country; when one's diversification and reach is unparalleled...one can justifiably 'look in the mirror' and see a reflection of 'STABILITY' staring back.

This is Sri Lanka Insurance Corporation today...the current definition of stability.

OUR VISION

To be the trusted insurer to the nation.

OUR MISSION

To be a customer-focused company that is trusted, which constantly innovates in providing insurance services of best value to our customers, whilst rewarding our employees and adding value to our shareholders.

Contents

1.0	Highlights	1 – 2
1.1.0	Financial Highlights	1
1.2.0	Operational Highlights	2
2.0	Messages	3 – 18
2.1.0	Chairman’s Message	4
2.2.0	Managing Director’s Review	12
3.0	Management Discussion and Analysis	19 – 54
3.1.0	Operating Environment	20
3.2.0	Financial Review	25
3.3.0	Operations Review	44
4.0	Corporate Governance	55 – 69
4.1.0	Board at the Helm of Stewardship	56
4.2.0	Board of Directors	59
4.3.0	Senior Management Team	64
4.4.0	Organisational Structure	68
5.0	Enterprise Risk Management	70 – 90
6.0	Audit and Compliance Committee Report	91

7.0	Financial Reports	97 – 254
7.1.0	Annual Report of the Board of Directors of the Company	99
7.2.0	Statement of Directors' Responsibility	107
7.3.0	Chief Executive Officer's and Chief Financial Officer's Responsibility Statement	108
7.4.0	Certificate of Actuary of the Insurer	110
7.5.0	Liability Adequacy Test	111
7.6.0	Certification of Incurred But Not (Enough) Reported Claims	112
7.7.0	Independent Auditors' Report	113
7.8.0	Statement of Financial Position	116
7.9.0	Statements of Profit or Loss and Other Comprehensive Income	118
7.10.0	Statement of Changes in Equity	120
7.11.0	Statements of Cash Flows	124
7.12.0	Segmental Review: Statement of Income	126
7.13.0	Segmental Review: Statement of Financial Position	130
7.14.0	Notes to the Financial Statements	134
8.0	Supplementary Information	255 – 281
8.1.0	Statement of Financial Position of the Life Insurance	256
8.2.0	Notes to the Financial Statements – Life Insurance Fund	257
8.3.0	Ten Year Summary	266
8.4.0	Glossary	274
8.5.0	Branch Offices	275
8.6.0	Corporate Information	278
8.7.0	Notice of Annual General Meeting	280
	Form of Proxy	Enclosed

1.1.0 FINANCIAL HIGHLIGHTS

	2014 Rs. million	2013 Rs. million	Change %
Total Revenue	29,302	27,981	4.7
Gross Written Premium	20,666	21,351	-3.2
Net Earned Premium	17,805	17,805	0.0
Profit Before Taxation (PBT)	4,373	6,355	31.18
Profit After Taxation (PAT)	3,257	4,655	30.00
Total Assets	162,192	143,556	13.0
Return on Assets (%)	2.0	3.2	34.375
General Insurance			
General Insurance Fund	13,196	13,289	-0.7
Net Claims Ratio (%)	63	52	21.7
Expense Ratio (%)	40.43	27.08	13.35
Life Insurance			
Life Insurance Fund	74,706	66,511	12.3
Expense Ratio (%)	46	40	12.5
Face Value Bonus	4,764	4,462	6.8
Ratings			
Fitch Ratings			
National Insurer Financial Strength	AA (Ika)	AA (Ika)	
National Long-Term Rating	AA (Ika)	AA (Ika)	
Outlook	Stable	Stable	
Lanka Rating			
Long-Term Claims Paying Ability	AAA	AAA	
Short-Term Claims Paying Ability	P1	P1	
Outlook	Stable	Stable	

Profit for the year
over

Rs. 3 billion

Total Assets
over

Rs. 162 billion
(Company)

Size of the
Life Fund

Rs. 75 billion

Total Bonus
issued for the year

Rs. 4.8 billion

1.2.0 OPERATIONAL HIGHLIGHTS

Customers		
Market share	Number of customers (Policies in force)	New customers acquired in 2014
Life Insurance 18.19% (No. 2 in the Industry)	Life Insurance 553,271	Life Insurance 57,426
General Insurance 21.47% (No. 1 in the Industry)	General Insurance 1,179,937	General Insurance 364,021
A network of 117 Branches and 5 Customer Service Centres		Rated by Fitch, Lanka Ratings

Employees		
A staff strength of 2,349 personnel	122 training and development programmes held during the year	Investments in training and development for the year exceeds Rs. 9 million

Society, Government and Economy
Contribution to the Government as taxes over Rs. 2.4 billion

2.0
Messages

*A VIEW FROM THE
TOP – THE YEAR GONE BY;
THE COMPANY’S
PERFORMANCE HIGHLIGHTS
IN CONTEXT AGAINST ITS
STRATEGIES; AND THE FUTURE*

2.1.0 CHAIRMAN’S MESSAGE

Looking back over a year that has undoubtedly been a turning point for the country, where history books have been rewritten and new chapters inked, for Sri Lanka Insurance Corporation Ltd., the macro milieu has been quite advantageous, enabling the Company to move steadily ahead to achieve its vision. Taking over the reins to helm this august institution which has played a dominant role in the national economy since 1962, I have the enviable task of being given the mantle from some of the country’s exemplary leaders who have spearheaded the course of this entity in the past.

This state-owned institution truly underlines the concept of ‘Stability Defined’, having continued to reiterate its prowess within an intensely competitive industry. SLIC has carved historic milestones along its legendary journey including possessing the largest asset base and the largest life fund within the insurance industry. Constantly pioneering, this year’s performance has continued to showcase consistent growth, a facet well evident in this review of the Company’s performance over the last year and one which I’m pleased to present to you, our stakeholder.

OBSERVATIONS ON THE GLOBAL ECONOMY

There was little redress seen in the global economy’s performance over 2014, despite great expectations. The expected momentum did not materialise from developed countries and emerging economies were less dynamic than in the past. There was just marginal growth from 2.5% to 2.6%, while growth in 2015 is believed to stand at 3% and average about 3.3% through 2017. Soft commodity prices, persistently low interest rates and a decline in oil prices since mid 2014 will support global activity and hopefully offset some of the headwinds. However, while the latter will grant some relief to oil-importing developing countries, it will undoubtedly dampen growth prospects for oil-exporting countries.

While the US and UK did see some activity due to labour markets becoming more active and monetary policy being accommodative, on the converse, the legacies of the financial crisis intertwined with structural bottlenecks dogged Japan. China too began undergoing a carefully managed slowdown. Developing countries were disappointing reflecting weak external demand, domestic policy tightening, political uncertainties and supply-side constraints.

According to The World Bank, South Asia continues as the fastest growing region in the world given that the region posted 5.5% growth in 2014, rising from a ten year low of 4.9% in 2013. The upturn was driven by India in strong expansion mode, coupled with favourable oil prices. The South Asia Economic Focus Report posits that regional growth will continue to increase from 7% in 2015 to 7.6% by 2017. India's reforms easing supply constraints, political tensions subsiding in Pakistan, Bangladesh and Nepal posting robust remittances and demand for the region's exports will surely be the panacea in driving this much expected growth, as is maintaining strong consumption and increasing investment.

SRI LANKA CONTINUES CONSISTENT GROWTH PARADIGMS

Showcasing its characteristic resilience and ability to constantly perform under pressure, Sri Lanka's growth continues to outpace its regional counterparts, sitting comfortably at a GDP growth of 7.4%, better than last year's 7.2%. The Central Bank of Sri Lanka's Department of Census and Statistics declares that the lower growth rate, compared to the forecast 7.8% however, was primarily due to the comparatively slow growth of 6.4% recorded in the last quarter of the year. The World Bank said growth in Sri Lanka is expected to decline to 6.9% in 2015 due to slowing construction activity, partially set off by consumption growth observed due to increased public sector wages and higher disposable income.

Sri Lanka has also performed significantly well in global indices including the Global Prosperity Index, Ease of Doing Business Index and the Global Competitiveness Index, been the highest ranked in South Asia in most of these. From a financial perspective, Fitch Ratings affirmed Sri Lanka's long-term foreign and local currency issuer default rating at BB-, reflecting the international investor community's confidence in the economy.

According to analysts, the economy has progressed close to upper middle income category and the main issues facing the country have also transformed. The challenges observed are curtailing corruption and establishing better law and order. Political uncertainties will create short-term volatilities in the economy, but the improved fundamentals will assist to drive the economy at a similar or faster pace than the last five years. While the Colombo Stock Exchange has seen lacklustre price movement, there could be a sentiment of stronger investment opportunities in the market, with better valuations.

Sri Lanka is focusing on long-term strategic and structural development challenges as it strives to transition to an upper middle-income country. This therefore brings forth a slew of diverse challenges including boosting investment and development of human capital, realigning public spending and policy with the needs of a middle-income country and enhancing the role of the private sector. Sri Lanka's growth and competitiveness is constrained by a skills gap that has emerged due to transformations observed in labour market conditions and an educational structure not responding to the needs of the job market.

It is also an economy that's no longer dominated by the agriculture sector but rather by services, followed by industry and manufacturing. Employment patterns have therefore followed these trends, shifting significantly from agriculture to industry and services. Labour productivity levels must be pushed up with the mismatch between graduates and private sector needing particular attention. Fostering a workforce that's employable is a priority to improve the quality of human capital through effective education and skills development.

THE INSURANCE INDUSTRY IN BRIEF

As detailed by the Central Bank of Sri Lanka, the insurance industry posted assets growth of approximately 13%, continuing to remain resilient albeit slowing down compared to the previous year's performance. By end of 2014, Fitch Ratings gave the industry a stable outlook, despite the impending split of composite insurers into life and non-life companies. This is, based on the view that most insurers will maintain stable financial fundamentals in 2015, supported by moderate sector growth. Fitch Ratings also expects economic growth and under-penetration in the market to support the growth of total gross written premiums (GWP), while significant improvement in life penetration in the short term, due to low disposable income will not see more than moderate growth in life premiums. Viewing the split of composites positively, adding that this will add greater transparency and policyholder protection, it also posits that some insurers may face operational uncertainties. Such that, post-split ownership structures and capital requirements may have a bearing on the credit profiles of individual life and non-life companies.

Minimum regulatory capital has been increased to Rs. 500 million from Rs. 100 million, risk-based capital (RBC) will replace the current rule-based solvency regime by 2016 and insurance companies are required to list by 2016 apart from some exemptions. Along with the stringent regulations, there will undoubtedly be market consolidation in the medium to long-term, which will augur well to consolidate and protect the high number of insurers in Sri Lanka.

Weaker capitalisation, sustained losses and a strong macro-economy will be the sensitivities that will impact the insurance industry post 2014. A significant decrease in capitalisation and solvency ratios due to the split of the composites, could lead to a negative outlook as any weakening in risk capital due to profit volatility or higher equity exposure in investments will be negatives for issuer ratings. The industry will also have to contend with growing price competition in motor, leading to weak technical results and significant reduction in investment income due to falling interest rates. Fragmentation of markets due to recent surge of competition is seen to exert downward pricing pressure on market leaders as newer entrants vie for market share at the expense of operating profitability. This will result in sustained losses which would naturally cascade as a negative for the non-life industry. However, the brighter side of the outlook is in the macro-economy, which is expected to showcase significant growth in real GDP product, permeating to higher disposable income and thus, a deeper insurance penetration.

It is this lacklustre penetration that needs to be addressed, given that it remains yet in single digits, despite an industry that has potential to be a significant contributor to the economy and should have matured given its history of well over seven decades. I do believe that the industry has considerable potential for expansion, primarily in the Life sector, especially among the lower and middle income earning communities. The sector contributes a dismal 1.5% of GDP, although the envisaged contribution should ideally be between 2% and 3% at current level of market development. I'm of the view this is the collective responsibility of the entire industry as it is our obligation and duty to ensure that we communicate the quintessence of the advantages of obtaining insurance in a clear, concise and comprehensive manner.

We must ensure that our message is one which is understood by the target market which underlines the fact that insurance is an imperative, rather than an option. It should be featured as an investment proposition aimed at safeguarding the future of not only the policyholder but also his/her family, adding financial security and stability throughout life, rather than being a monetary benefit gained after death. It is absolutely crucial that we communicate this message unequivocally; stating the 'real' positives that accrue to a policyholder, so that they feel compelled to invest and gain the advantages of having a secure and stable future.

CAPITALISING ON OUR FINANCIAL STRENGTHS

The industry did not experience any drastic transformations during the year given the slow growth rate, which reflected on SLIC's performance as well. A complete financial review is available in the Managing Director's Review as well as the Financial Review and Financial Statements found elsewhere in this Report. In synopsis, SLIC experienced a decline of about 3% on pricing and we also lost about 2% of our market share in Life. However, SLIC has always prided itself on its visionary thinking, pragmatism and an insatiable need to overcome challenges. This has driven us to infuse progressive strategies that will enable us to re-capture our market share and definitely work on a strategy that will enable us to grow this share even further. I see immense potential in the plans we are now implementing and coupled with the competencies and skill of our dynamic team, these goals are surely attainable sooner rather than later.

Our asset base of over Rs. 162.19 billion is the largest in the country, as is our Life fund of Rs. 74.7 billion. We also have a policyholder base of 550,000 plus for our life insurance business and 1,179,937 for our general insurance business, which surely places us among those at the zenith of the industry. We have clearly defined targets and mileposts to make these numbers move on an upward spiral in the years ahead. With our financial fundamentals being strong, consistent and well-founded, we have been lauded with numerous rankings that reiterate our financial strength and prowess. We remain the only insurer in Sri Lanka to be ranked AAA by Lanka Ratings and AA (lka) by Fitch Ratings London.

The profit before tax of Rs. 3.3 billion due to life and general premiums recording key performance, have enabled SLIC to continue its sustained growth trajectory, despite emerging volatility both in the macro milieu and market from time to time.

A factor that did impact our business was the pressure on margins, due to the prevalent low interest regime prompting stakeholders to transfer products to gain advantage of product costs. However, the strategic investments made has resulted in an impressive profit on investments, posting an encouraging increase of Rs. 11,217 million, from Rs. 9,275 million posted last year, reiterating our focused strategy on ensuring the right mix within our investment portfolio and a strategic plan that would ensure sustainable returns from these investments.

We have always maintained a prudent risk management milieu, maintaining minimal risk via reinsurance agreements placed with our overseas partners. Reinsurance covers most of the risk undertaken for general insurance, which although impacting our profits, enables us to maintain risk at manageable levels.

SUBSIDIARIES GAIN MOMENTUM

There has always been an overarching rudiment of performance excellence that governs the Group. The need to outperform each year by building and nurturing on the inherent strengths we possess has pushed us to pursue new opportunities pragmatically and with vision.

Sinolanka Hotels & Spa (Pvt) Ltd., a sub-subsidiary of SLIC, is currently engaged in the construction of the Hyatt Regency, Colombo, which is billed for completion by December 2016. This landmark skyscraper has already gained much repute not only as an international hotel chain establishing a strong presence in Sri Lanka and naturally push benchmarks prevalent within the tourism industry to higher realms, but also in construction capabilities, given the hallmark architecture, concept and design it will feature.

Canowin Hotels and Spas (Pvt) Ltd., the subsidiary managing the rest stop on the Southern Expressway has seen significant increase in footfall, auguring well for a higher performance this year. We await further expansion of expressways in Sri Lanka in which we aim to capitalise on the advantages we foresee by expanding our presence and adding value to the infrastructure development being implemented by the State.

The largest importer and supplier of LP Gas in Sri Lanka, Litro Gas operates the country's only import terminal and filling facility. Able to cater to the entire country's LPG requirements given its comprehensive distribution network, Litro Gas also holds the distinction of being the oldest gas supplier in the country. The Company has continued to grow steadily and showcase consistent performance throughout the year, which has impacted the Group's bottomline positively.

The Lanka Hospitals Corporation PLC posted a landmark year, having gained the prestigious Joint Commission International Accreditation, making it a member of the elite collective of just 450 hospitals around the world. It remains one of the most accredited hospitals in the country, etching pioneering pathways including becoming the only healthcare provider in Sri Lanka to ever win the Global Performance Excellence Award conferred by the Asia Pacific Quality Organisation. This means that The Lanka Hospitals also surpassed its vision of being the foremost and preferred healthcare facility in the country in 2014. It also inked a pioneering initiative this year with the establishment of Lanka Hospitals Diagnostic (LHD), the first-ever reference laboratory in the country, equipped with cutting-edge technology designed for faster response times in the diagnostics process.

MOVING AHEAD

I observe considerable opportunity for expansion of our distribution channels, via branches and agents, aimed at making insurance a more inclusive product and an advantage we must afford to the nation's citizenry as an imperative. While technology will be used to optimise our reach, we also remain cognisant to the fact that the Sri Lankan psyche requires the presence of brick and mortar structures to assert presence, where communicating directly with a team member and prompting a dialogue process is important. We will continue having a physical presence in the industry therefore, given that our aim is to grow our business via penetration and by presenting a customer service genre constructed on a one to one communication process. With these, we will surely gain considerable advantage among our competition. Our ultimate goal therefore should be to reach out to more places than any other in the insurance industry.

Having analysed the product portfolio available within the industry, there is considerable potential in product development, where innovative products customised to suit various and diverse customer segments must be presented as options to our clientele. Innovation is the key to gaining market share and studying market trends and paradigms both local and global, coupled with constant feedback from customers and potential customer demographics, will enable us to continually innovate our product portfolio. Reinvigorating products and service levels by revolutionising thought processes and augmenting skills and capabilities will motivate branches and agents to optimise their marketing abilities, given that our products will not only be innovative, but be responsive, have differentiation and be unique in the marketplace.

While the industry is getting more competitive, there is also a danger of it becoming more fragmented if more new players enter the market. It is imperative therefore that the bigger players act and operate responsibly, ethically, accountably and transparently, acknowledging their leadership roles to lead and guide the industry into a milieu of high performance. This also pushes the industry to take collective decisions on its future and be united for higher innovation, better product differentiation and inclusive penetration. The market must be competitive and be a level playing field, eschewing any unethical practices to gain unfair advantage. The collective vision should be in growing the insurance industry for the benefit of the nation and its people; matching growth trends that prevail in China and India.

IN APPRECIATION

Spearheading this legendary insurance entity is certainly a prestigious appointment, but with it also comes a permeating responsibility to ensure that as an industry leader, we must champion the cause to reach new heights, while taking the Company to higher realms. While thanking my Board of Directors, senior management and the team for their support and guidance in ensuring that we make pragmatic decisions that will impact positively for a sustainable business, I look forward to working with you in reiterating SLIC's position at the helm of this industry.

I also extend appreciation to the Insurance Board of Sri Lanka and other germane regulatory authorities for the advice and continuous consultation we have been gaining from you and look forward to a continuance of the dialogue we have now begun. The advice and guidance given by the Ministry of Finance on a timely basis is much valued.

The former Chairmen and Board of Directors have completed a very successful year for SLIC for which I thank them most sincerely, looking forward to building on the positives they have constructed to create a sustainable business entity.

As we embark on a new year, our qualitative and quantitative performance underscores the fact that we have worked within a milieu of 'Stability Defined'. While we have had our share of challenges, these have been used as learning curves to enable us to redefine our plans and create a blueprint that will take us forward. 'Stability Defined' also means that we have to work that much harder to transform our weaknesses into strengths and threats to opportunities, which will enable us to push towards capturing the market share we lost, innovate much more to define our product portfolio and train, develop and motivate our team to always be ahead to optimise on emerging opportunities. It is this that will push us into leadership position in life insurance once again, a goal we have now established to achieve in three years and one that will grow on the base of being a stable progressive visionary organisation built on solid teamwork.



Hemaka D.S. Amarasuriya

Chairman

1st June 2015

2.2.0 MANAGING DIRECTOR'S REVIEW



*THE CONCEPT OF STABILITY IS
CHALLENGING ONE GIVEN THAT IN AN
INTENSELY COMPETITIVE ENVIRONMENT,
MAINTAINING STABILITY IS A
FUNDAMENTAL TO THE SUSTAINABILITY
FOR ANY ORGANISATION*

For Sri Lanka Insurance Corporation Ltd., stability has always remained an overarching tenet, which has been constructed on a strong foundation of financial strength, knowledge prowess and a governance framework that truly defines our stability. It is this that has been the formula for our consistent success and has enabled SLIC to weather the storms of challenges and emerge triumphant, seeking opportunities to grow in multi-faceted ways. This then is how stability is defined and how we have made it our unique competitive advantage.

With the country's development path now looking towards even more aggressive growth plans, an underlying factor in these plans is the crucial role that has and must be played by the financial services industry. Pushing a path of inclusive sustainable growth, the insurance industry will unequivocally be called upon to be a catalyst in this growth paradigm given its stronghold in Government funds which can be one of the imperative tools that will etch this growth pathway. It is in this backdrop that I present my review for the year ending 2014, proudly holding aloft the fact that Sri Lanka Insurance Corporation continues to be the largest insurer in Sri Lanka.

OUR OPERATING ENVIRONMENT

The insurance industry consists of 29 insurance companies. A pervasive factor observed is that most of the interaction by the industry, remains concentrated in urban areas and non-life penetration, albeit yet limited, is better than life penetration. Hence, the potential for business growth is immense, especially in reaching out to the rural and semi-urban areas. One such segment we see growth potential is in agricultural areas, where customised insurance solutions will surely be the value addition to the challenges faced by the farming community and enable a much better economic contribution from this segment of the economy.

The life sector is considered a non-necessity and will be availed upon only as a last resort or when excess disposable income is available, which is a massive shortfall in the perception of life insurance among stakeholders. The industry has been unsuccessful in communicating the importance of life insurance and the value additions it imbues, which has in turn led to a lack of interest in purchasing life insurance and thereby, the insurance companies neglecting the sale of such policies. The cycle must be reversed and to reverse it, the industry must take action to be more persuasive and have clarity in the dialogue process they engage in. Products must be customised to suit each economic segment, being more attuned to the requirements of the stakeholder, rather than a 'one size fits all' policy. The policy must be one that remains tied to the policyholder throughout their life span.

Growth of non-life business remains at a higher level than life due to the compulsory insurance policies required for motor, business and other germane requirements. It is almost rare for customers to seek non-life policies that are not mandatory, content with only the basic cover. Given this mindset, insurers also tend to focus more on non-life business as growth is assured at this level. However, once again, the insurance industry has not focused greatly on penetration and widening the scope of business, being placid in the retention of the business at hand, rather than aggressively seeking opportunities for varied solutions that are currently seen elsewhere in the world.

Increasing penetration is the panacea to growing the industry and this can only be done if the industry itself is well aligned to customer requirements, expectations and aspirations. The industry must customise policies that would meet these needs and thus become an imperative, rather than a choice which can be availed of later. With the per capita income billed to increase to US\$ 4,000 by 2016, the industry must capitalise on the opportunities that arise with this higher level of income and standard of living.

SYNOPSIS OF PERFORMANCE

Having concentrated on increasing penetration, life business, of which we hold 40% of the entire fund in the country, posted growth aligned to industry average, although general insurance, while notching some growth, was less than the industry average. However, the year itself has been a challenging one for SLIC where even though we did post impressive results continuing to remain at the helm in profitability, financial performance and consistent growth, we were challenged in realising the forecast growth.

As we look at your Company's quantitative performance, SLIC recorded a profit before tax of Rs. 3.26 billion for the year, compared to Rs. 4.65 billion recorded last year. Life insurance premium was Rs. 8,121 million, while general insurance premium was Rs. 12,544 million for the period. The life fund is detailed at an impressive Rs. 74.70 billion, which although having paid large maturity and advance payouts to longstanding customers, also showcases that SLIC's entire persona is constructed around stability, especially in financial consistency and financial strength. The combined Gross Written Premium (GWP) recorded Rs. 20.67 billion, with life and non-life business in GWP growing 35.14% and 35.38% respectively over the five years post-re-nationalisation.

One of our biggest strengths and certainly a factor that defines our stability, remains the unprecedented bonuses we declare. Another is the conscious, informed and timely decisions

made on opportunities that evolved in the capital market, enabling us to boost investment income to achieve exceptionally high-levels. This has resulted in the SLIC life fund, largest in the industry, recording consistent growth in investment income.

We have always believed in nurturing the relationships we have with our customers, strengthening their trust in us by delivering on our promises, which also includes astute management of our well-matured life insurance fund and prudent investments. Having honed our customer service to levels that have created strong stakeholder relationships where the commitment of our team to ensure that our policyholders get the best, has seen customer loyalty at a record high. An enviable half a million policyholders is impressive by any standards, undoubtedly reiterating, 'Stability Defined'. I feel very proud to pronounce that SLIC declared an unmatched bonus of Rs. 4.8 billion for the year, the highest ever in the history of the insurance industry of Sri Lanka.

While insurance remains our core business, SLIC has been strategically diversifying, identifying key growth industries and astutely imbuing investments into these business areas. Our investment portfolio's diversified nature is well seen in the fact that we are key investors in tourism, hospitality, energy and health, all earmarked growth industries positing well for good Return on Investments (ROI) on our investments. Already, some of these investments have infused considerable ROIs to our bottomline, while also enabling us to seek other value adding avenues of growth and emerging areas of opportunity. As can be observed, our investments our strategic, pose minimum risk and are certainly well-endowed to augment our investment portfolio quantitatively and qualitatively.

Our business ethos is one of sustainable development, an inherent mindset that permeates the way we do business, product development, customer interaction and stakeholder engagement. For instance, the launch of an innovative health policy this year is geared to ensure the well-being of people, where a healthy nation can undoubtedly contribute towards ambitious economic development being chartered by the country. Similarly, education remains high on our agenda of social responsibility initiative, as by creating pathway to hone knowledge among the younger generation, we will assist in building a competent and skilled force who will add value to national development. The cash rewards presented at the *Life Suba Pathum* scholarship scheme for high achievers in the Grade 5, O/Level and A/Level examinations examples our commitment to sustainable knowledge gain.

GOVERNANCE AND REGULATION

One of the strong fundamentals in the way we operate our business is having a strong governance and compliance culture. This is an imperative in our business practice and is something we remain very cognisant of. Prudent business strategies, operational excellence, astute risk and investment management and far thinking reinsurance practices all form the axis upon which our business revolves on. Adequate liquidity and a portfolio of highly marketable Bonds and Treasury Bills pave the way for SLIC to be ready at any time to meet stakeholder obligations, while product development and innovation leads the way in ensuring insurance solutions that are unique and timely. As the largest Government insurer, we are aware of the responsibility we are tasked with in ensuring that an unshakeable foundation of trust is well- entrenched into both the quantitative and qualitative best practices we permeate. The fact that we are the first and only insurance company in Sri Lanka to be certified with ISO 9001:2008, reiterates our commitment to governance and accurate and timely operational, processes, systems and standards.

Regulated as we are by the Insurance Board of Sri Lanka, the Risk-Based Capital (RBC) framework which was introduced to the industry, aims to protect the interests of stakeholders and minimise the risk of possible financial crises. In the directive under the Insurance Industry (Amendment) Act No. 03 of 2011, capital adequacy requirements and the solvency positions have also been introduced to create a more sound and well governed industry.

PLANS AHEAD

We have now embarked on a three-year Strategic Plan which sets out the blueprint for SLIC to regain its market share thereafter grow incessantly, identifying our strengths and fortifying those even further. Bridging the gaps that exist including transforming inherent weaknesses into advantages and seeking to exploit opportunities that continue to emerge are also within the plan. Our immediate focus is on channel development with emphasis placed on agency growth, which we believe is the way forward for the plans we have mapped out. The current branch network of 117 along with 15 customer service centres will be further expanded, strategically placed to maximise on the geographic location.

Similarly, innovation will be the catalyst in product development. Having always had a pulse on customer expectations and requirements, we intend to hone the feedback and dialogue we have with our customers even further, gaining firsthand knowledge of the solutions they require and customising these insurance solutions innovatively. In tandem, our team, together with our agency force will continue to be motivated. The excellent results they have consistently showcased displays the absolute commitment and dynamism this force, pushing boundaries with a will to win, even in the most intensely competitive eras.

ACKNOWLEDGMENTS

It has undoubtedly been an excellent year for us, while it has also been a learning curve. But through it all, we have been able to uphold the high levels of trust and the responsibility given to us by our customers, a feat that has been daunting but rewarding. Thank you to our policyholders, both individual and corporate, who have continued to drive our success. Our valued business partners including banks, brokers and other financial institutions, your partnerships mean much to the sustainability of our business and we appreciate your input.

I thank the Chairman and Board of Directors for the responsibility given to me to manage this august institution and am appreciative of the direction, guidance and consultation you extend to me so generously. The excellent results posted this year is primarily due to the unwavering commitment of our amazing team, whose professionalism shines above all else and certainly one to be emulated.

Also, we sincerely acknowledge the corporation extended to us by the Board of the Insurance Board of Sri Lanka. We are also grateful to the Ministry of Finance for the directions and guidance given.

As we step into a new chapter in our history, I have steadfast belief that SLIC is now ready to etch new paths in the industry in Sri Lanka. We have always been a leader and this leadership mantle is one which we take seriously, creating benchmarks and industry standards that set the path for others to follow. We will always retain the focus of our mission of being a customer focused company that is trusted, constantly innovating to provide best value to customers, while rewarding employees and adding value to shareholders. Being a lifelong partner to our stakeholders is the crux of our existence, while building a business that makes us the trusted insurer to the nation, as our vision states.

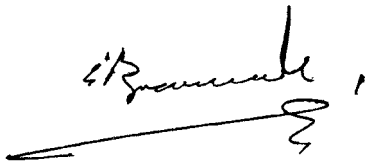

T.M.R. Bangsa Jayah
Managing Director

1st June 2015

*WE ENSURE GOOD BUSINESS
PERFORMANCE THROUGH
OUR UNWAVERING
COMMITMENT TO CREATING
SUSTAINABLE VALUE FOR ALL
OUR STAKEHOLDERS*

3.1.0 OPERATING ENVIRONMENT

3.1.1 GLOBAL ECONOMY

The global economy grew by a modest 3.4% in 2014, reflecting an increased growth momentum in advanced economies and a slowdown in emerging markets and developing economies relative to year 2013.

Growth was divergent among major economies. This was due to improved disposable incomes as a result of lower commodity prices, continued support from accommodative monetary policy stance and moderate fiscal adjustments. The recovery of the US was stronger than expected, with consumption being the main engine of growth. Weak consumption and plummeting residential investment caused Japan to record a weak growth in 2014. The activity in the Euro area was weaker than expected with a favourable outlook for 2015 supported by lower oil prices and higher net exports.

After a decade of very rapid growth, economic activity softened in emerging and developing Europe. This reflects the weak growth in advanced economy trading partners since the global financial crisis, growth moderation in China and also a variety of country-specific factors. However, Asia and Pacific region remained the leader in world economic growth in 2014.

Complex forces which affected global activity in 2014, continued to shape the outlook. These include population aging, declining potential growth, lower oil prices and many country or region specific factors. Accordingly, global growth is projected to rise to 3.5% and 3.8% in 2015 and 2106 respectively. These are in-line with the projections of the January 2015 World Economic Outlook (WEO) Update.

3.1.2 LOCAL ECONOMY

Amid diverse developments in the global economy, Sri Lanka recorded a real GDP growth of 7.4% in 2014, compared to the 7.2% in 2013. The main engine of growth was domestic consumption expenditure that constitutes the largest share of aggregate demand. Investments; construction in particular, provided an impetus to economic expansion during the year as well. On the production side, economic growth was led by the industry and service sectors, whilst adverse weather conditions dampened the performance of the agriculture sector.

3.1.2.1 ECONOMIC GROWTH

The services sector, which accounts for 57.6% of GDP, grew by 6.5% in 2014, compared to the growth of 6.4% in 2013. This was due to significant contribution from wholesale and retail trade, transport, communication, banking, insurance and real estate sub-sectors.

The contribution of the industry sector increased to 32.3% of GDP, recording a growth of 11.4% in 2014, compared to 9.9% in the previous year. The construction sub-sector was the highest contributor to the industry sector with substantial contribution from food, beverages, tobacco, textile, wearing apparel and leather sub-sectors.

The agriculture sector was impacted by adverse weather conditions, growing marginally by 0.3% in 2014, thereby reducing its share in GDP to 10.1% from 10.8% in 2013. Several key sub-sectors including paddy, rubber and minor export crops contracted, largely contributing to the deceleration of growth in the agriculture sector.

3.1.2.2 INFLATION

Inflation remained at single digit levels for the sixth consecutive year, with both year-on-year and annual average inflation declining to 2.1% and 3.3% respectively, by end 2014. The corresponding values were 4.7% and 6.9% respectively at end 2013. This is due to the impact of demand management policies, improved supply conditions, downward revision of administered prices and effectively contained inflation expectations.

3.1.2.3 UNEMPLOYMENT RATE

With increased employment opportunities as well as a reduction in the Labour Force Participation Rate (LFPR), there was a decline in the unemployment rate from 4.4% to 4.3% during the year.

3.1.2.4 EXTERNAL TRADE AND THE BALANCE OF PAYMENT

Sri Lanka's external sector displayed resilience in 2014 with a narrowing of external sector imbalance and a surplus in the overall BOP. Export earnings grew at a healthy rate of 7.1%, supported by improved external demand along with a stable domestic macroeconomic environment. Import expenditure recorded an increase of 7.9% in 2014 year-on-year, led

by imports of intermediate goods and consumer goods, particularly during the second half of the year.

The current account deficit was reduced by the increased inflows from trade in services as well as higher workers' remittances during 2014.

The external debt position of the country increased on account of foreign borrowings, issuances of international sovereign bonds and the international debt securities issued by deposit-taking corporations.

Due to the improvements in the current account and net inflows to the financial account during 2014, the BOP recorded a surplus of US\$ 1,369 million from US\$ 985 million in 2013. Accordingly, the gross official reserves by end 2014 improved to equivalent of 5.1 months of goods imports.

3.1.2.5 ECONOMIC OUTLOOK

Going forward, the Sri Lankan economy is projected to reach upper middle income levels and sustain the favourable high growth and low inflation regime in the medium term, supported by appropriate economic policies. Upholding policies of good governance and transparency, the new Government is expected to support a high growth path through an improved investor friendly environment.

In the medium-term, Sri Lanka is projected to record a real GDP growth of 7.0% in 2015 mainly due to the slowdown in public sector construction activity and conservative sentiment of private investors, though with the resumptions of capital investments in public sector, GDP growth would reach 7.5%. Growth supporting domestic policy framework, improved investor sentiment and improvements anticipated in the global economic activity, is expected to accelerate economic activity which is projected to average 7.8% over 2016 to 2018.

Through improved productivity supported by the adoption of advanced technology, enhanced human resources and new investment initiatives of the private sector, the agriculture, industry and services are expected to bolster economic growth.

Due to capacity expansion through new investment initiatives and prudent monetary policy measures the annual consumer price inflation is anticipated to be 3.0% in 2015 and approximately 4.0% thereafter.

3.1.3 INSURANCE INDUSTRY

The insurance sector, which accounted for 3.4% of the financial sector assets in Sri Lanka, maintained its stability in 2014. At present there are 29 insurance companies operating in Sri Lanka, which are registered with the Insurance Board of Sri Lanka (IBSL). In addition, there were 59 insurance brokering companies concentrating mainly on general insurance businesses. There were approximately 36,518 insurance agents in 2014, through whom most of the insurance business was distributed throughout the country.

The level of expansion of the insurance sector in Sri Lanka is relatively slow as reflected by low penetration and density. Insurance density being the ratio of total premium to total population was Rs. 4,962 million in 2014, compared to Rs. 4,613 million in 2013. This was due to several factors such as attitudes of the general public towards insurance, lack of adequate awareness, inefficiencies in policy management and lack of appreciation for the concept and benefits of insurance.

3.1.3.1 BUSINESS GROWTH

The total assets of insurance companies recorded a healthy growth of 13.2% to Rs. 411.7 billion as at end 2014, compared to 13.0% in 2013. Total assets in respect of long-term insurance business which accounts for 61% of total assets, increased to Rs. 249.9 billion as at the end of 2014.

The Gross Written Premium (GWP) of insurance companies grew by 8.6% in 2014, compared to 8.4% in 2013, thus reversing the continuous moderation since mid 2011. This was due to the relatively high growth in premium income of the general insurance sector, particularly, motor insurance and fire segments.

The GWP for general insurance, accounting for 57.5% of the total GWP, grew by 10.9% to Rs. 59 billion. In comparison, the GWP for long-term insurance, which accounts for 42.5% of the total GWP, grew by 5.6% to Rs. 44 billion. However, with the introduction of different product strategies, such as life insurance, single premium insurance (annuities) etc., there is a huge potential for the long-term insurance business in the future.

3.1.3.2 PROFITABILITY

With the moderation of total investment income and low underwriting profits, the profitability of the insurance sector declined in 2014. Accordingly, the aggregate profit before tax declined by 27.9% to Rs. 9.7 billion compared to Rs. 13.5 billion in the previous year. The total investment income of insurance companies increased by 14.9% to Rs. 33.3 billion during 2014, due to the significant performances of equity market and higher investments in corporate debt securities.

3.1.3.3 CAPITAL AND INVESTMENTS

The soundness of the insurance companies was maintained during the year. All insurance companies, except one, met the statutory solvency margin requirement for general and long-term insurance in 2014. The solvency margin ratio for general insurance decreased marginally to 2.4 times at end 2014 from 2.6 times at end 2013. The solvency margin ratio for long-term insurance increased to 9.8 times from 8.9 times at end 2013. Reflecting the improved capital levels in the insurance sector, the ratio of capital to total assets increased to 63% in 2014 from 57% as at end 2013.

3.1.3.4 STRENGTHENING SOUNDNESS

The minimum regulatory capital of insurance companies has been increased to Rs. 500 million from Rs. 100 million. The current rule based solvency requirement would be replaced by the proposed risk-based capital (RBC) adequacy framework by 2016. This has already encouraged better discipline in the investment function in the sector which would result in greater precision in measurement of capital on a risk-adjusted basis and promote better risk management. In addition, the mandatory public listing by 2016 will improve policyholder protection through greater transparency and better governance.

3.2.0 FINANCIAL REVIEW

3.2.1 FINANCIAL RESULTS

As at 31st December 2014, the Company's asset base reached Rs. 162.19 billion compared to Rs. 143.56 billion in 2013. SLIC also recorded the highest ever Shareholders' Fund of Rs. 64.25 billion in 2014, compared to Rs. 53.18 billion in 2013. In addition, the Life Fund swelled to Rs. 74.70 billion from Rs. 66.51 billion the previous year.

The combined Gross written Premium (GWP) increased to Rs. 20.67 billion from Rs. 21.35 billion in 2013. The net profit for the year is Rs. 3,257 million and Rs. 4,654 million recorded for the year 2013.

3.2.2 SOLVENCY RATIO

SLIC maintained the required solvency margins during the financial years 2014 and 2013. Accordingly, the solvency ratio of the life insurance business was 13.22 whilst the general insurance business was 3.80 for the year 2014. The solvency ratios for the corresponding year for life insurance and general insurance were 11.48 and 4.93 respectively. The admissible assets of the life insurance business amounted to Rs. 82,660 million as against Rs. 73,346 million in 2013. The liabilities for 2014 stood at Rs. 52,065 million compared to Rs. 48,539 million in 2013. Total admissible assets of the general insurance business were Rs. 26,702 million whilst the liabilities amounted to Rs. 16,281 million in 2014. The corresponding values for 2013 for admissible assets and liabilities were Rs. 30,327 million and Rs. 16,498 million respectively.

3.2.3 COMBINED BUSINESS PERFORMANCE

	SLFRS				SLAS
	2014	2013	2012	2011	2010
	Rs. '000	Rs. '000	Rs. '000	Restated Rs. '000	Rs. '000
Revenue	29,301,980	27,980,865	25,644,316	17,207,928	35,011,286
Gross Written Premium	20,665,987	21,350,869	20,172,623	18,220,673	15,276,496
Net Earned Premiums	17,804,907	17,805,056	16,768,442	14,422,101	11,979,746
Benefits, Losses and Expenses	(18,928,978)	(16,467,823)	(15,625,259)	(7,718,624)	(16,768,863)
Investment and Other Income	11,497,075	10,175,809	8,875,874	2,785,827	23,031,540
Interest Expense	(35)	(138)	(223)	(37)	(210)
Operating and Administrative Expenses	(5,999,828)	(5,158,022)	(4,155,575)	(4,054,181)	(3,208,095)
Profit Before Taxation	4,373,139	6,354,868	5,863,255	5,433,086	15,034,118
Taxation	(1,116,126)	(1,700,039)	(1,627,413)	(1,220,547)	(1,994,915)
Profit After Taxation	3,257,013	4,654,843	4,235,842	4,214,539	13,039,203

Combined Gross Written Premium

Rs. million

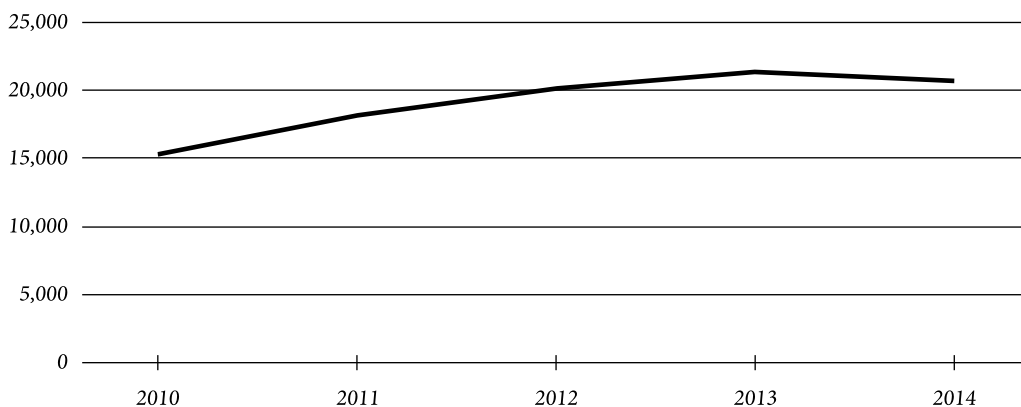

As illustrated above, the combined GWP of the Company has increased by 35.27% over the last five years from Rs. 15,276 million in 2010 to Rs. 20,665 million in 2014. Investment income and other income have also expanded by 12.99% from Rs. 10,175 million in 2013 to Rs. 11,497 million in 2014. The PAT amounted to Rs. 3,257 million in 2014.

3.2.4 GENERAL INSURANCE BUSINESS PERFORMANCE

	SLFRS				SLAS
	2014	2013	2012	2011	2010
	Rs. '000	Rs. '000	Rs. '000	Restated Rs. '000	Rs. '000
Gross Written Premium	12,544,828	12,953,151	12,803,491	11,477,600	9,266,637
Net Earned Premiums	9,820,149	9,504,974	9,487,217	7,828,645	6,034,185
Net Claims Incurred	(6,205,796)	(4,934,075)	(6,194,011)	(4,970,962)	(2,885,793)
Operating and					
Administration Expenses	(3,977,357)	(3,351,580)	(2,528,520)	(2,453,660)	(1,917,779)
Investment and Other Income	2,224,732	2,516,798	2,064,835	(245,498)	10,112,693
Interest Expense	(14)	(51)	(110)	(12)	(98)
Profit Before Taxation	1,861,713	3,736,068	2,829,411	158,513	11,343,207
Taxation	(217,101)	(803,033)	(900,971)	(407,432)	(843,740)
Profit After Taxation	1,644,613	2,933,034	1,928,440	(248,919)	10,499,467

Gross Written Premium – General Insurance Business

Rs. million

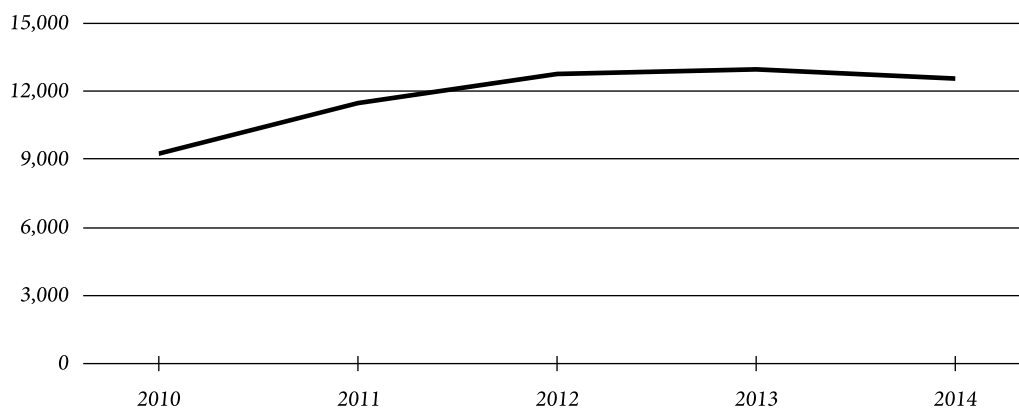

The GWP of the general insurance business reflected an increasing trend over the last five years from Rs. 9,266 million in 2010 to Rs. 12,545 million in 2014, indicating a 35.38% growth. The general insurance business for the years 2014 and 2013 amounted to Rs. 2,224 million and Rs. 2,516 million respectively. The PAT for the year was Rs. 1,645 million.

3.2.4.1 STABILITY OF GENERAL INSURANCE BUSINESS

Insurers are required to maintain sound solvency margins for both life and general insurance businesses, as per Section 26 (1) of the Regulation of Insurance Industry Act. The solvency margins maintained by the Company for both life and general businesses are given below:

	SLFRS				SLAS
	2014	2013	2012	2011	2010
	Rs. '000	Rs. '000	Rs. '000	Restated Rs. '000	Rs. '000
Net Assets Value	45,697,972	38,909,641	30,748,097	25,298,629	27,323,020
Solvency Ratio	3.80	4.30	3.27	1.94	2.11

Net Assets Value – General Insurance

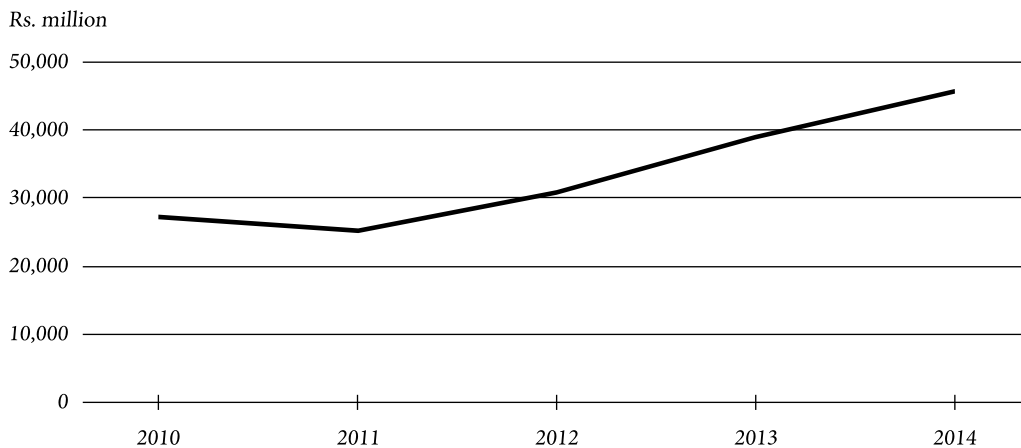

3.2.4.2 APPROVED ASSETS OF GENERAL INSURANCE BUSINESS

	2014 Rs. million	2013 Rs. million	2012 Rs. million	2011 Rs. million	2010 Rs. million
Approved Assets for Technical Reserves	16,808	22,760	20,720	17,983	15,030
Technical Reserve Values	11,929	11,881	12,570	11,740	11,001
Approved Assets in Excess Technical Reserves	4,879	10,879	8,150	6,243	4,029

3.2.5 LIFE INSURANCE BUSINESS PERFORMANCE

	SLFRS				SLAS
	2014 Rs. '000	2013 Rs. '000	2012 Rs. '000	2011 Restated Rs. '000	2010 Rs. '000
Gross Written Premium	8,121,159	8,397,718	7,369,029	6,743,073	6,009,859
Net Written Premium	7,984,758	8,300,082	7,281,225	6,593,457	5,945,561
Investment and Other Income	9,272,541	7,659,011	6,811,040	3,031,325	13,026,350
Claims Incurred	(5,733,524)	(4,870,410)	(4,089,231)	(3,592,818)	(4,957,675)
Commission Expenses	(1,127,919)	(1,053,299)	(1,088,644)	(933,627)	(648,033)
Management Expenses	(2,507,813)	(2,307,020)	(2,147,076)	(1,924,534)	(1,483,218)
Increase in Life Fund Before Taxation	7,887,844	7,728,364	6,767,314	3,173,803	11,882,985
Taxation	(899,025)	(897,006)	(726,442)	(813,114)	(1,151,175)
Increase in Life Fund	6,988,818	6,831,358	6,040,872	2,360,689	10,731,810

Gross Written Premium – Life Insurance Business

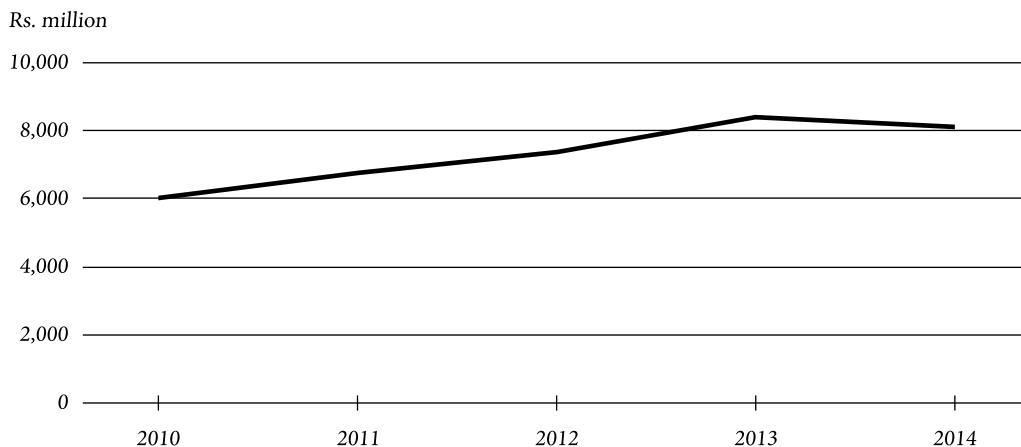

As illustrated above, the GWP of life insurance business has increased over the last five years from Rs. 6,009 million in 2010 to Rs. 8,121 million in 2014, recording a growth of 35.14% over the 5 years. The investment income and other income of the life insurance business also recorded a 21.02% growth year-on-year, from Rs. 7,659 million in 2013 to Rs. 9,272 million for the year 2014. The life fund increased by 12.32% compared to 2013.

3.2.5.1 STABILITY OF LIFE INSURANCE BUSINESS

	SLFRS				SLAS
	2014	2013	2012	2011	2010
	Rs. '000	Rs. '000	Restated Rs. '000	Rs. '000	Rs. '000
Life Fund	74,706,065	66,511,606	60,084,899	55,860,476	49,569,355
Net Assets Value	18,625,842	14,373,046	17,547,244	16,627,365	31,295,966
Solvency Ratio	13.22	11.48	10.14	9.95	6.11

Increase in Life Fund

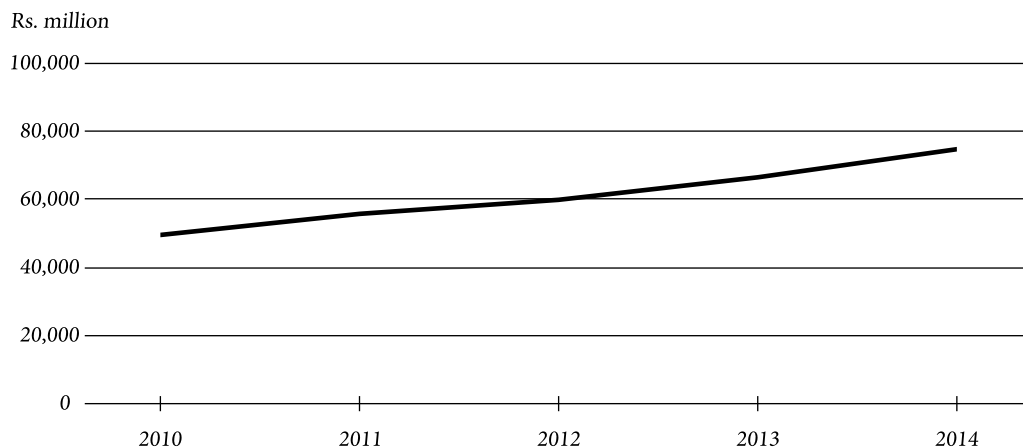

The solvency ratio for the life insurance business remained at a two digit level indicating the highest level of stability. Accordingly, the solvency ratio stood at 13.22 in 2014, whilst it was 11.48 times in the corresponding year.

SLIC recorded the highest life fund in the industry amounting to Rs. 74,706 million in 2014 and Rs. 66,512 million for 2013.

3.2.5.2 APPROVED ASSETS OF LIFE INSURANCE BUSINESS

	2014 Rs. million	2013 Rs. million	2012 Rs. million	2011 Rs. million	2010 Rs. million	2009 Rs. million
Approved Assets for Life Fund	77,715	69,740	61,428	57,911	52,247	44,918
Life Fund Values	74,706	66,511	60,085	55,860	49,569	41,484
Approved Assets in Excess Life Fund	3,012	3,229	1,343	2,051	2,678	3,434

FACE VALUE OF BONUS

SLIC has consistently declared an increasing bonus to its policyholders. Accordingly, the bonus declared for the financial year 2014 amounted to Rs. 4.7 billion, reflecting a growth of 6.77%.

Year	Face Value of Bonus Rs. million
2010	3,438
2011	4,014
2012	4,183
2013	4,462
2014	4,764

Face Value of Bonus

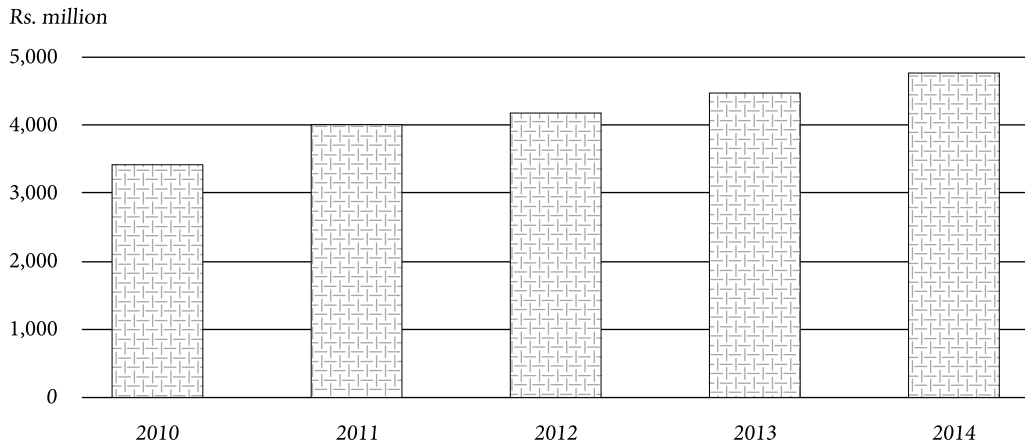

3.2.6 VALUE ADDED STATEMENT OF THE COMPANY

	2014 Rs. '000	2013 Rs. '000
Net Earned Premium	17,805	17,805
Investment and Other Income	11,497	10,176
	29,302	27,981
Less		
Net Claims and Benefit	11,939	9,804
Cost to External Services	3,527	2,735
Value Addition	13,836	15,442
Distribution of Value Added		
To Employees		
Salaries and Other Benefits	2,335	2,007
To Intermediaries		
Acquisition Cost	1,613	1,554
To Government		
Income Tax	1,116	1,700
To Life Policyholders		
Increase in Life Insurance Fund	5,376	5,109
To Shareholders		
Dividend Paid	1,002	1,200
To Expansion and Growth		
Retained as Depreciation	138	418
Retained as Reserves	2,255	3,454
	13,836	15,442

Distribution of Income – 2013

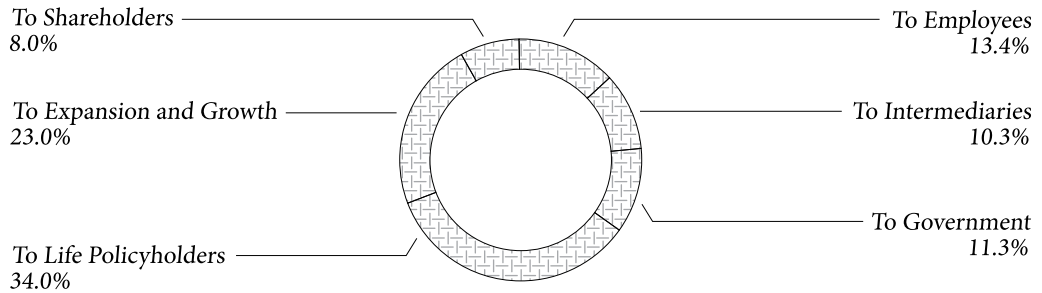

Distribution of Income – 2014

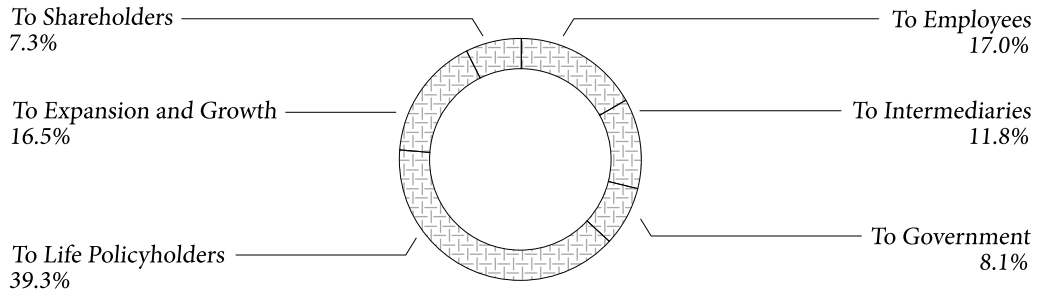

The value added statement reflects the manner in which the value addition is distributed among the employees, intermediaries, government, life policyholders and for expansion and growth.

3.2.7 INVESTMENTS

3.2.7.1 INVESTMENT STRATEGY

The investment strategy of SLIC is geared to achieve the optimal balance in safety, income and asset growth. Through prudent investment management principles within applicable regulations of the IBSL, the strategy is aimed at meeting the obligations of the Fund.

3.2.7.2 INVESTMENT COMMITTEE

The Investment Committee has a range of responsibilities including, the management of SLIC's investment portfolio, reviewing & monitoring the strategic asset allocation, effective matching of assets & liabilities and capitalising the tactical investment opportunities. The Committee adheres to the Asset Manager's Code of the CFA Institute and with the reconstitution of the Board of Directors on 20th January 2015, the Committee was also reconstituted as given below:

Board Members:

- Mr. Imal Fonseka – Chairman of the Investment Committee
- Mr. Hemaka D.S. Amarasuriya – Chairman of the Board
- Mr. T.M.R. Bangsa Jayah – Managing Director
- Mr. P.P.J. Perera – Executive Director

Investment Managers:

- Mr. Dhanuka Liyanagamage – Asst. General Manager/Investments

Other Staff Members:

- Mr. Ranjith Perera – Senior Deputy General Manager/Finance
- Mr. Chaminda Gunasinghe – Asst. General Manager/Finance

Invitees:

- Mr. Nalin Subasinghe – Asst. General Manager/Actuarial Services

The quorum of the Investment Committee is 03 members including at least one Board Member.

3.2.7.3 ASSET ALLOCATION

Life Fund Portfolio – 2014

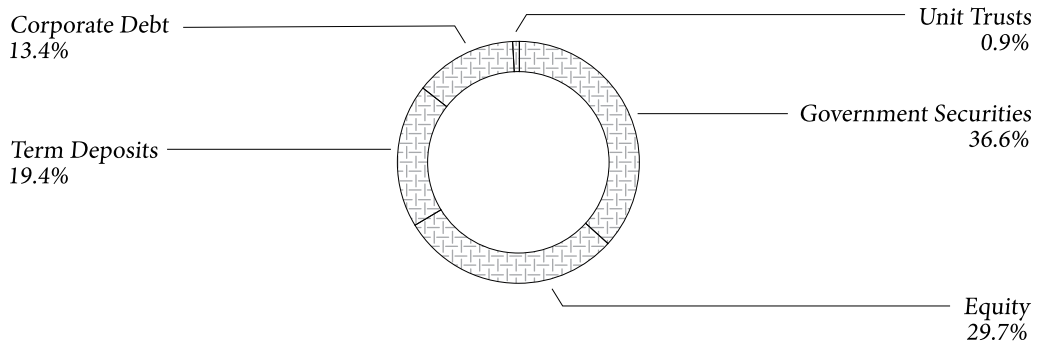

Growth of Investable Assets – Life Fund

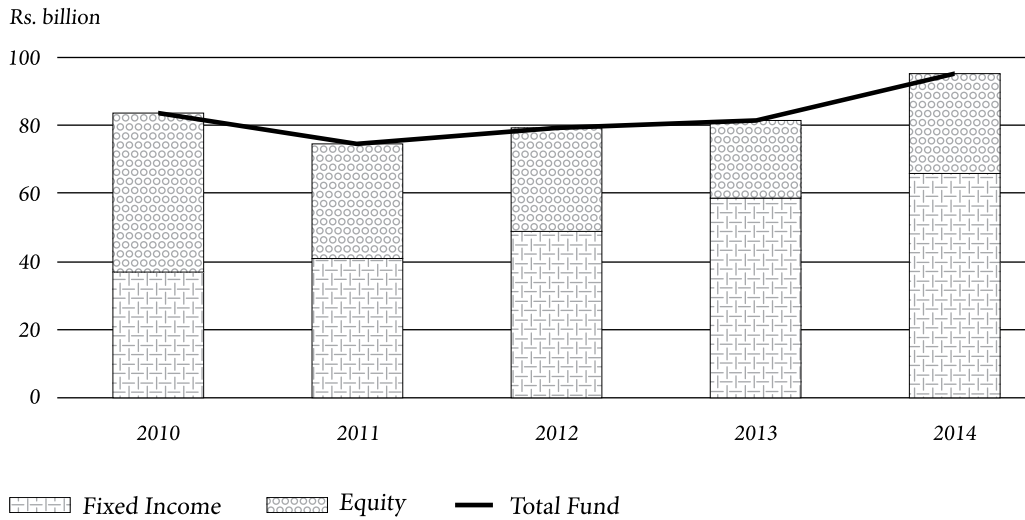

General Fund Portfolio – 2014

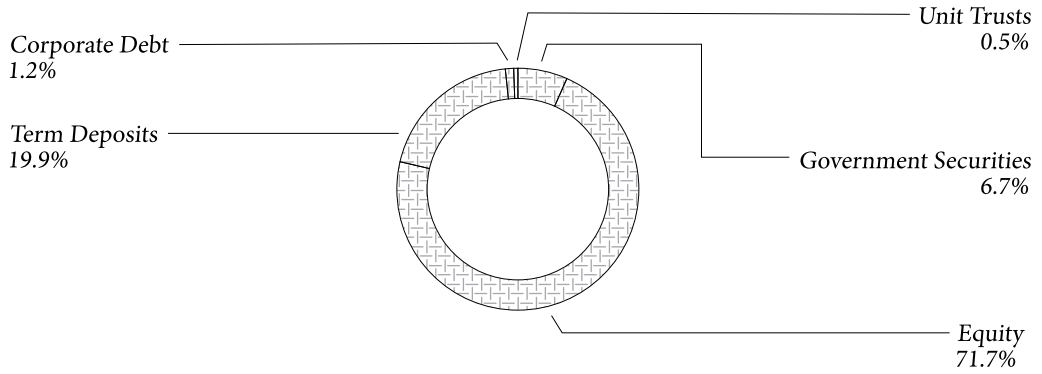

Growth of Investable Assets – General Fund

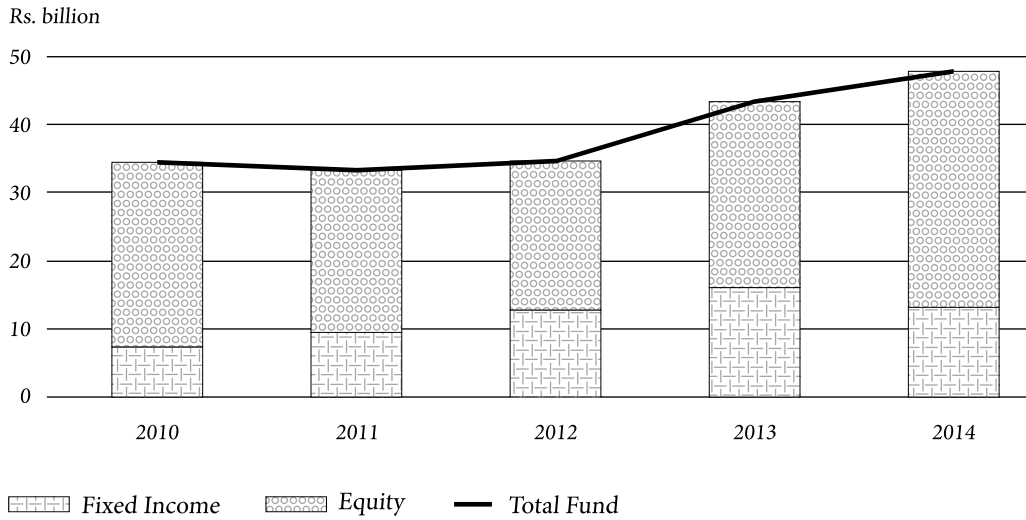

3.2.7.4 ASSET - LIABILITY MATCHING

LIFE FUND

In the context of a relatively less-developed fixed income securities market, matching the maturity structure of the Life Fund is a challenging task. However, the significant number of listed debentures issued during the year, helped to mitigate this risk to a considerable extent. Most of these issues were heavily oversubscribed as the investors rushed to reap the benefits of income tax waivers granted. SLIC invested Rs. 4.3 billion in listed debentures during the year with maturities ranging upto 5 years.

With many firms opting to raise funds through debentures, there is a high probability of more listed debentures being issued in the ensuing year.

Further, the investments in Government Securities reached Rs. 7 billion with maturities extending upto 30 years. The Company intends to invest in longer term bonds as well in 2015 in order to reduce the asset-liability mismatch in the Life Fund further.

GENERAL FUND

Unlike Life Fund assets, obligations of the General Fund are short-term in nature and hence a major part of the fund was invested in short-term assets.

3.2.7.5 INVESTMENT PERFORMANCE

The Company achieved healthy returns during 2014 for both Life and General funds under prudent and dynamic investment management mechanisms, avoiding undue risks. This is a commendable performance in an environment where the interest rates remained at historical lowest levels.

SLIC recorded a total investment income of Rs. 11.2 billion during the year.

Investment Income – Life Fund

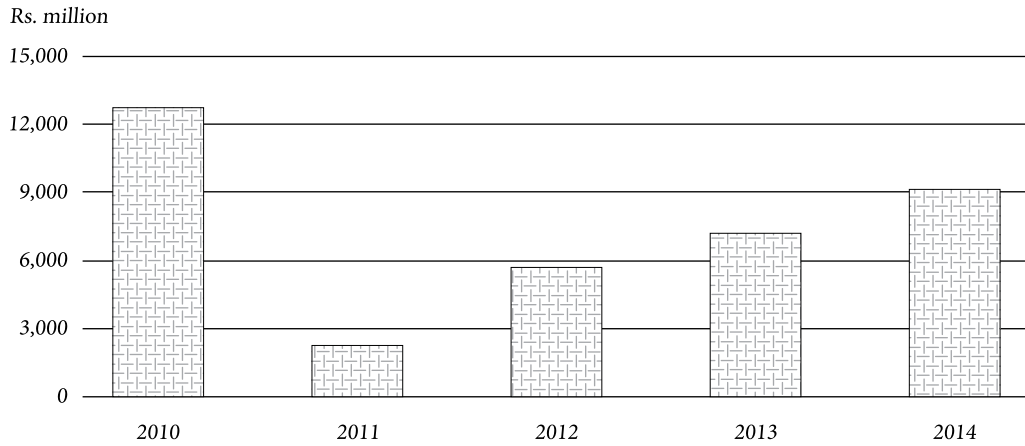

The Life Fund recorded a healthy investment income of Rs. 9.1 billion in 2014, which is a substantial 26.5% increase compared to the previous year.

Investment Income – General Fund

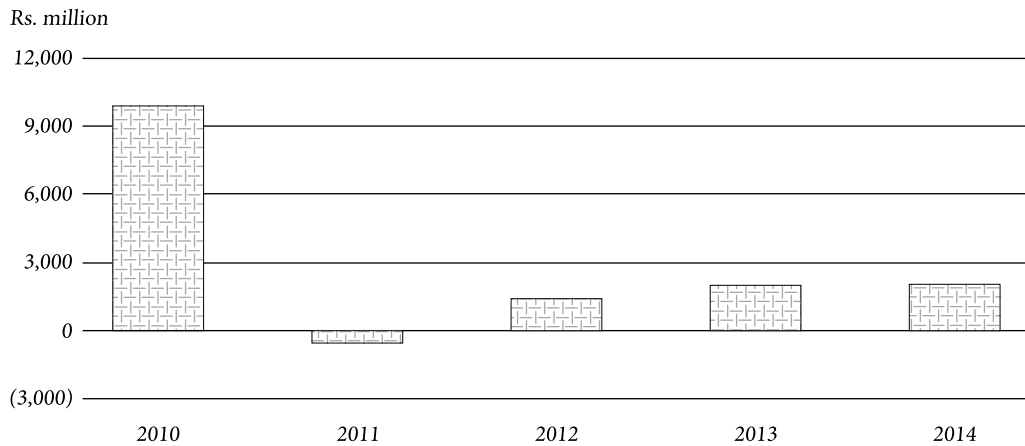

The General Fund recorded an investment income of Rs. 2.1 billion in 2014, recording a growth of 2.2% year on year.

INVESTMENTS

(Rs. '000)	2014	2013	2012	2011	2010
At Cost					
Listed Subsidiaries	2,925,567	2,925,567	2,925,567	2,925,567	2,925,567
Unlisted Subsidiaries	18,160,337	14,660,337	13,790,250	8,790,250	7,040,250
Available-For-Sale					
Listed Stocks	35,711,339	24,798,653	22,423,654	22,748,462	33,286,320
Unlisted Stocks	143,257	124,480	90,581	81,554	113,137
Unit Trusts	1,146,236	1,426,408	1,437,209	2,270,657	2,250,138
Listed Debentures	11,880,406	7,190,339	3,424,049	2,972,856	2,075,449
Treasury Bills	-	483,700	-	-	-
Treasury Bonds	4,387,187	5,418,642	11,144,843	11,964,725	5,848,601
Fair-Value-Through-Profit-or-Loss					
Listed Shares	5,538,348	5,956,726	10,953,886	20,795,497	28,030,158
Held-To-Maturity					
Treasury Bills	487,576	-	969,775	192,899	190,787
Treasury Bonds	25,589,291	19,324,293	14,402,918	18,240,876	21,742,403
Loans & Receivables					
Unlisted Debentures	1,367,205	1,890,781	2,274,245	2,015,204	1,562,458
Term Deposits	27,945,442	22,864,910	16,290,231	7,080,518	9,396,500
Development Bonds	2,428,326	5,254,857	5,106,038	4,586,578	4,498,515
Commercial Papers	-	-	206,807	332,352	-
Trust Certificates	-	37,481	60,767	53,260	57,609
Reverse Repos	5,130,628	12,530,569	7,852,673	3,065,689	279,251
Total	142,841,145	124,887,745	113,353,493	108,116,944	119,297,144

SUBSIDIARIES

Sri Lanka Insurance Corporation Ltd., has invested in a diversified portfolio including the following subsidiaries, as detailed in the Annual Report of the Board of Directors of the Company. The ensuing paragraphs provide financial and operational highlights of the same.

LITRO GAS LANKA LTD.

Litro Gas Lanka Ltd. (LGLL) recorded revenue of Rs. 3,834 million during the year 2014. The revenue has grown up from Rs. 28,106 million to Rs. 29,080 million during the year demarcating a 3.47% growth. Despite two times price reductions which had a major impact on the business, the Company was still able to increase its revenue. Total assets were Rs. 21,167 million as at 31st December 2014, compared to Rs. 18,477 million the last year. The total asset base increased by 14.55% for the year 2014. The Company has paid taxes to the Government, amounting to Rs. 1,529 million in 2014. In addition, the Company has paid dividends of Rs. 275 million to its shareholders during the year.

LGLL remains deeply committed to sustainability in its operations to ensure the safety and well-being of the communities in which it operates. About 40% of the world still cooks with solid fuels, such as wood and coal, in simple stoves that release substantial amounts of the same types of hazardous chemicals found in tobacco smoke, directly into the household environment. LPG represents a phase in the transition to more advanced modern fuels, replacing traditional fuels. Studies indicate that most countries with per capita household incomes of USD 4,000 have already completed this transition. Therefore, the major focus of LGLL is to engage in strategic expansion in non-urban areas, where LPG is still to take hold.

LITRO GAS TERMINAL LANKA (PVT) LTD.

At Litro Gas Terminal Lanka (Pvt) Ltd., the turnover for the year was Rs. 998 million compared to Rs. 933 million for the previous year, mainly due to increase in volume. Operating expenditure increased from Rs. 349 million to Rs. 370 million, mainly due to variations in the elements of lease rental. Net finance income reduced from Rs. 284 million to Rs. 236 million, mainly due to a 17% reduction in investment income. The effective interest rate on short-term investment in Treasury Bills was reduced from 12.97% in 2013 to 7.78% in 2014 and the said variation in net finance income was affected from this considerable change in the effective interest rate.

THE LANKA HOSPITALS CORPORATION PLC

The Lanka Hospitals Corporation PLC (LHCL) is a 240-bed tertiary care hospital focusing on providing affordable healthcare. Cardiology, fertility and kidney transplants are the fast becoming specialty areas of the hospital. As a benchmarked leader in the healthcare sector, LHCL has championed to newer heights with the conferring of the Joint Commission International Accreditation (JCIA) during the year. LHCL is now among an elite collective of just 450 hospitals around the world to have this prestigious accreditation.

The financial performance during the year was also remarkable. The Group net revenue increased by 17% to Rs. 4.8 billion, the highest in the history of LHCL. The Group net profit of Rs. 510 million was the second highest profit recorded since inception of the hospital. Further, from year 2010 to 2014, net assets have grown by 67% due to infrastructure developments and technology improvements.

CANWILL HOLDINGS (PVT) LTD.

Canwill Holdings (Pvt) Ltd. (CHL), was established in the year 2011. Grand Hyatt Colombo (GHC) is a fully-fledged multifaceted iconic 5-star luxury class hotel, under construction at present and to be completed by end 2016. The hotel will be managed by Sinolanka Hotels & Spa (Pvt) Ltd. (SHS), which is owned by Canwill Holdings (Pvt) Ltd. Upon completion, the property will be the tallest building in Sri Lanka and will be named 'Grand Hyatt Colombo'.

The project configuration of GHC is 458 rooms, 90 operational serviced apartments, a large banquet hall with a capacity to accommodate over 1,500 guests, 8 restaurants offering a wide range of cuisine, an infinity swimming pool and meeting rooms among the other high-end luxury amenities. The hotel rooms and serviced apartments will have an unparalleled, scenic view of the Indian Ocean.

SHS has obtained the services of numerous international contractors and consultants and is committed to undertake the project in adherence to the industry and Hyatt International standards. GHC will be managed under the 'Grand Hyatt' brand, an upscale brand of full-service hotels located in gateway cities around the globe. 'Grand Hyatt' is operational in 46 countries, with 508 properties managed under 8 different brands targeting various customer segments. The highly acclaimed 'Hyatt Gold Passport' loyalty programme would enable GHC to benefit from the vast network of 'Hyatt' chain tourists.

CANOWIN HOTELS AND SPAS (PVT) LTD.

As commuters drive along the Southern Expressway that take them to lush greenery and artistic rock faces, the rest areas known as 'Canowin Arcades', owned and managed by Canowin Hotels and Spas (Pvt) Ltd., which is a fully-owned subsidiary of Sri Lanka Insurance Corporation Ltd., serve as a modern day concept of 'Ambalama'. The rest areas consist of rest rooms, restaurants, super markets, souvenir shops and vehicle parks etc.

The loss after tax during the financial year is Rs. 19.7 million as against Rs. 51.4 million profit after tax during the previous year. The main reason for the loss for the year is due to the impairment of the property by Rs. 70 million.

The rest areas have been developed on a fully-fledged approach that will be linked in future to the other highways as well.

3.3.0 OPERATIONS REVIEW

3.3.1 CUSTOMERS

Customers play an imperative role in our journey towards sustainable performance. As the largest and strongest composite insurance provider in Sri Lanka, we remain customer centric in our approach. Through continuous process improvement, elevated service standards, enhanced convenience and the offer of products that meet the current and emerging insurance needs of customers, we create increased value for our loyal customers.

3.3.1.1 OVERVIEW OF THE PERFORMANCE OF BUSINESS UNITS

Over the last 5 years, we have gathered momentum in the industry as reflected in the significant business growth. The GWP increased by a commendable 54% with Life Business expanding by 70% and General Insurance recording a 45% growth during this period. Effective strategies have been implemented for each line of business to achieve optimal results. These efforts have enabled General Insurance to become Number One in the industry for 5 consecutive years with approximately a 22% market share and an 18% market share in Life Insurance.

Increasing active manpower in the sales force has been a key focus area which will bear dividends in the future. We are exploring avenues of growth in General Life Business, which has a high potential for growth. Accordingly, we have entered into agreements with People's Bank, National Savings Bank, Bank of Ceylon and Regional Development Bank. Our new channel development strategies will bear fruit going forward. A comprehensive Health Assurance was launched during the year, which is the best in the market at present. We are in the process of reinvigorating the Retirement and Child Categories as well.

Although, the Motor Business was challenged during the year, we focused on entering into agreements with larger players in the financial services sector, which would reap benefits in the years ahead.

The retail market kept the business intact with agreements being entered to across the branch network. The retail segment of Non-Motor was another focus area with effective business mapping and penetration initiatives being launched. This would facilitate a better business mix in the portfolio.

The sales force recognition schemes through promotion-based competitions launched for both Life and General Insurance, encouraged hundreds of members to qualify for rewards inclusive of foreign tours.

Customised sales training and development was carried out throughout the year facilitating the expansion of the knowledge base.

3.3.1.2 SRI LANKA INSURANCE HEALTH

We launched our newest addition to our product line up; the Sri Lanka Insurance Health, that looks after numerous medical needs of the citizens of our nation.

This covers an extensive range of medical needs, customised to the specific needs of customers. It includes 4 unique health insurance packages which can be added on to the Life Insurance policy of an existing policy holder. They are, SLIC Comprehensive Plan, SLIC Overseas Comprehensive Plan and SLIC Surgical Plan.

SLIC Annual Medical Plan is a short-term health solution which can be renewed annually. This consists of five different packages, based on the insured value. The policy covers a range of medical expenses, including hospitalisation, surgery, maternity expenses and professional fees to name a few. The SLIC Annual Medical Plan also consists of a unique 'No Claim Bonus', which increases the basic sum insured by 5%, up to a maximum of 50%, for every claim free year.

3.3.1.3 SRI LANKA INSURANCE MOTOR PLUS LOYALTY REWARDS

As in the previous years, the Motor Plus Loyalty Rewards scheme was launched to provide a range of benefits to our loyal customers.

This year, we tied up with z-Messenger to offer Motor Plus Loyalty Rewards via the Bigbon mobile phone application. This facilitates Motor Plus customers to view the available offers of Motor Plus Loyalty Rewards by downloading the app.

Comprehensive Motor Plus Loyalty customers can avail themselves to a range of rewards including customer discounts from many prestigious merchants from motor spares, vehicles and lubricants to retail clothing and leisure sector. In addition, Sri Lanka Insurance Motor Plus has tied up with premier vehicle agents such as Senok, BMW, United Motors, Associated Motors, Toyota Lanka, Prestige Automobile (Pvt) Ltd., KIA Motors, DIMO, Carmart Ltd. for repair services after accidents for all Sri Lanka Insurance Motor Plus clients. Customers are entitled to these rewards at the time of renewal or purchasing a new policy.

3.3.1.4 SRI LANKA INSURANCE MOTOR PLUS INTRODUCES GLOBAL EMERGENCY ASSISTANCE SERVICES

The Sri Lanka Insurance Motor Plus created history by tying-up with a global emergency services company 'Assist America' to launch its newest value addition - 'Sri Lanka Insurance Motor Plus Global Emergency Assistance' Services.

This is a unique Emergency Assistance Service offered to all our comprehensive Motor Plus customers, travelling a distance of over 100 kms from their permanent residence for a maximum of 90 days, inclusive of overseas travel at a nominal annual fee. It provides emergency

medical consultations with doctors, emergency medical evacuations inland or abroad, hospital admission assistance and maintaining regular communication with the hospital on the progress of the customer and disseminates information to the family, as apt.

This also includes, arranging medical consultations, evaluation and referrals, medical monitoring and prescription assistance, compassionate visits, care of minor children, interpreter and legal assistance, lost luggage and document assistance, pre trip information service and return of mortal remains in case of unfortunate incidents as well.

3.3.1.5 SRI LANKA INSURANCE ADJUDGED BEST INSURANCE COMPANY IN SRI LANKA

For the 4th consecutive year, we bagged the most prestigious coveted award as the Best Insurance Company in the General Insurance Sector at the World Finance Insurance Awards 2014 organised by the World Finance Magazine, London.

The World Finance Awards identify industry leaders, individuals, teams and organisations that benchmarks achievement and best practices in the financial and business world across regions.

This award reflects our constant drive for innovation, originality and quality of product, as well as proof of market development and excellence in client representation. It is also a confirmation of the strong financial stability, high level of service standards together with the comprehensive product range offered to our customers in every strata of society.

3.3.1.6 INFORMATION TECHNOLOGY

Information Technology is vital to achieve our corporate objectives. IT facilitates improvement in our processes, expansion of the reach and offering enhanced convenience and an effective service to customers.

During the year in review, our key focus was enhancing system availability, customer reach and access by providing value added services through the latest technology. Our ICT network was further enhanced by upgrading the existing infrastructure and deploying IP based voice and video technology to reduce voice communication and security based operational expenses.

In addition, several IT initiatives were taken during the year to achieve business objectives. Accordingly, renewal of premium collections, customer notifications and customer service standards were improved. The automation of field force operatives was another IT enhancement that was effected which positively impacted the contact centre service standards to continue as the market leader of the industry in Sri Lanka.

3.3.2 EMPLOYEES

Employees are the most important resource for the growth and sustainability of an organisation. Therefore, developing and retaining the best talent within the organisation is crucial to maintain a competitive edge.

Analysis by Category

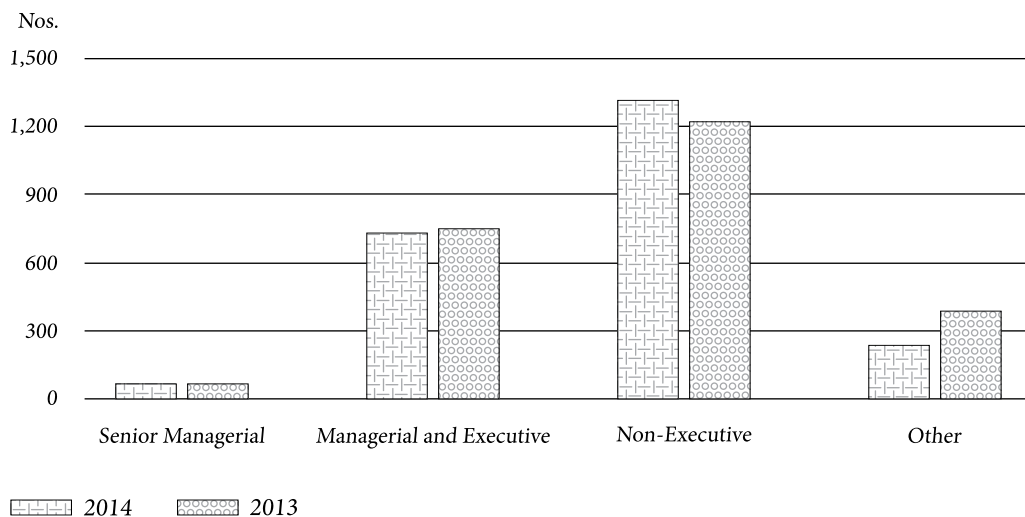

Gender Analysis

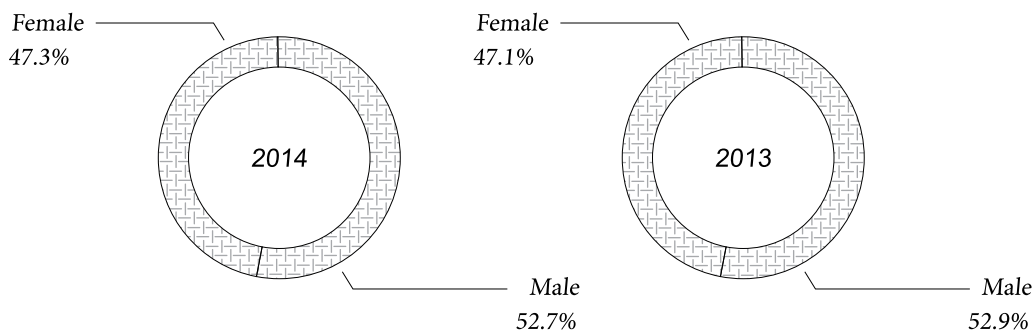

Employee Placement by Geographical Location

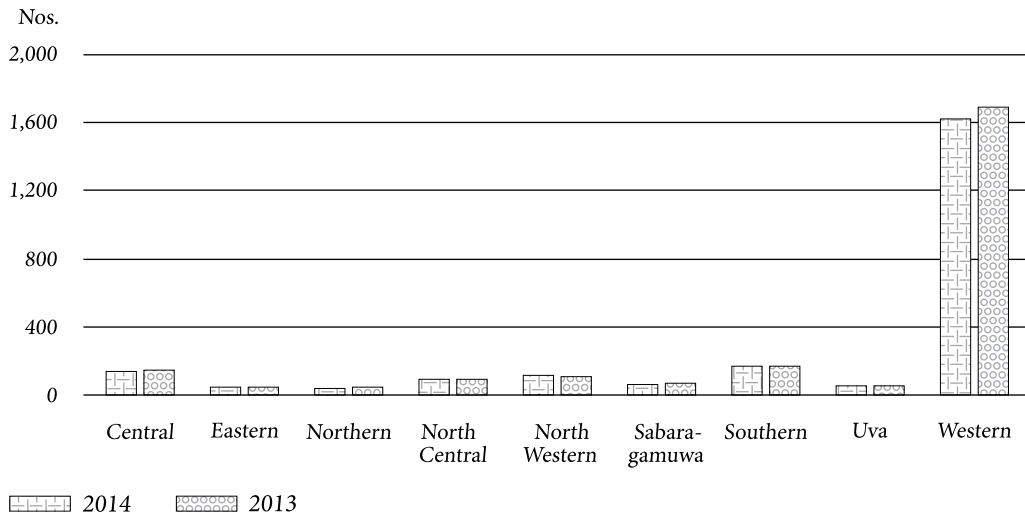

3.3.2.1 POLICIES AND PROCEDURES ON HR PRACTICES

In order to offer an enriched service to our staff members, we have in place a HR policy manual.

RECRUITMENT

When recruiting new staff, we adopt techniques such as aptitude tests, language tests, assessment centres and scenario analysis, in addition to panel interviews. This ensures systematic evaluation of the candidate’s knowledge, skills and attitudes.

COLLECTIVE AGREEMENTS

Identifying the importance of maintaining a good rapport, the management has entered into a collective agreement with two main trade unions which has facilitated a closer relationship between the management and employees. Signing of the collective agreement for 2013 – 2016 facilitated the revision of salaries to be in par with the industry standards. In addition, salary ranges were introduced to main staff categories to maintain internal and external equity as well as to attract and retain talent.

STAFF PROMOTIONS

Clear promotion paths were mapped out to ensure employees are given an opportunity to develop their careers within the Company, based on their skills and competencies. Further, competitive reward strategies were implemented to recognise best performers. In addition, every employee in our organisation is given an opportunity to apply for promotions annually, based on the criteria stipulated in the annual promotion policy. Moving away from traditional promotion methodologies we ensure that employees' knowledge, skills & attitudes are systematically evaluated during the promotion process.

SUCCESSION PLANNING AND TRAINING

Succession planning is established to develop the second tier of leaders to ensure business continuity. The identified successors are given training and other development opportunities to groom them for next promotions. The training opportunities include both local as well as foreign.

Training and development play an important role in developing and retaining the best talent within the organisation. The training programmes focus on developing knowledge, skills and attitudes of staff to best fit the organisations culture and setup. Training comprises of in-house, local and foreign, based on the identified need gaps of the staff members.

In-house training is customised based on the needs of the employee and company requirement. It is focused on developing both technical knowledge and competencies of employees. Local and foreign training are extended to bridge the knowledge, skills and competencies gaps of employees further. Foreign training is mainly aimed at developing the insurance and technical knowledge to achieve a competitive edge. Training is carried out based on the annual training calendar of our company. In addition, management development programmes are carried out to develop the next level of managers within the organisation.

INVESTMENT IN TRAINING AND DEVELOPMENT

Type	2014 Rs.	2013 Rs.
In-house Training	354,726	2,293,147
External Training	966,539	2,082,263
Conferences	398,945	962,922
Overseas Training	5,029,121	6,213,164
Insurance and Professional Education	647,391	331,728
Professional Memberships	1,679,730	1,689,516

TRAINING PROGRAMMES

	2014	2013
Number of Programmes	122	76
Number of Hours	656	569

INDUCTION PROGRAMMES

	2014	2013
Number of Programmes	7	20
Number of Hours	28	80

OVERSEAS EXPOSURE

	2014 No. of Persons	2013 No. of Persons
Technical	8	10
Sales and Marketing	1	2
ICT	2	1
Finance	1	2
Other	1	0

GRIEVANCE HANDLING

An open door policy is implemented within our Company enabling employees to interact with the management regarding their grievances. Further, we have in place a grievance procedure to identify staff grievances and solve them.

EMPLOYEE WELFARE

A separate welfare unit exists within our Company to look after the well-being of our staff members. Activities are carried out for the well-being of staff members as well as their family members. Facilities such as circuit bungalows, company transport facilities, death benefit schemes and programmes for children of staff members are available for welfare members.

3.3.2.2 SRI LANKA INSURANCE BAGS A SILVER AT THE HRM AWARDS 2014

We were awarded the silver award for the best HR System and processes at the 'HRM Awards 2014' organised by The Association of Human Resource Professionals (HRP) in collaboration with The Society of Human Resource Management (SHRM). The process involved an onsite audit to ensure precise and up-to-date HR systems and processes. The process of selection also included a comprehensive study of the organisation HR systems to ensure compliance with the organisations, business objectives and value addition to the organisation. We have always been focused on internal processes that are aligned with global standards to bring added dynamism to our organisation. In this process, high priority was given to our HR systems and initiatives on people development.

3.3.2.3 THE QUIZZ CHAMPS

Our team comprising HR and Legal, became champions of the Banking, Finance and Insurance sector at The Great HR Quiz -2014.

This is the biggest HR Quiz organised by, the Institute of Personnel Management (IPM) Sri Lanka. Sri Lanka's top 50 corporates comprising of multinationals, conglomerates, public and private sector organisations battled on one common platform for the award.

3.3.2.4 'HARASARA' AWARDS 2014

The 'Harasara' awards ceremony was organised to recognise and felicitate 139 staff members for their loyal service to the Company for over 25 and 35 years respectively. The event was graced by the Corporate Management of SLIC.

The recipients were presented with personalised plaques, certificates and gold coins as a tribute for their loyalty to Sri Lanka Insurance Corporation.

3.3.3 BUSINESS PARTNERS

Our business partners play a vital role in our business operations as we continually strive to offer a service level of the highest quality to our customers. Our business partners are reinsurers, brokers, advisors and suppliers. We have adopted sound policies, procedures and ensure compliance with relevant rules and regulations to drive sustainable and ethical business practices in our Company and also in our business partners. We also strive to generate greater value to our business partners and optimise their outcomes.

3.3.3.1 SRI LANKA INSURANCE ANNUAL SALES AWARDS NIGHT

Star Awards 2014 was held to facilitate the best performing sales personnel of our Company at the BMICH. The event was graced by the then Deputy Minister of Finance and Planning, Dr. Sarath Amunugama whilst the Board of Directors, Senior Management and over 1,300 attendees patronised the ceremony.

364 top insurance sales performers and team leaders were awarded for their excellent sales performance, sheer dedication and hard work. It was a glamorous evening with unique entertainment that kept the audience spellbound.

3.3.4 THE SOCIETY AND THE ECONOMY

As a responsible corporate citizen, SLIC always strives to create a significant impact on the community within which it operates. In our long years of serving the nation, we are fortunate to have served and supported our people in numerous ways. In return, we have earned the trust and appreciation of the communities around us.

3.3.4.1 NURTURING THE FUTURE OF OUR NATION

The Sri Lanka Insurance Life *Suba Pathum* scholarship scheme which provides financial assistance to students who have excelled at the Grade 5 Scholarship exams, G.C.E (O/L) and G.C.E (A/L) examinations. Over three hundred top ranking students in total, received Sri Lanka Insurance Life *Suba Pathum* Scholarships.

Top 4 students from each district who excelled in the grade five scholarship scheme received Rs. 20,000 lump sum while the top four district level ranking students of the G.C.E (O/L) received a lump sum of Rs. 40,000 each and top 100 students who excelled at national level at the G.C.E (A/L) examination comprising of 25 top ranking students each from the streams Bio, Mathematics, Commerce and Arts received a lump sum of Rs. 50,000 each. If the student's parents or guardian is a Sri Lanka Insurance Life Policy Holder, the benefit will be offered for a continuous period as an annual payment until the child faces the next national level examination. Eligible students had to apply for the Sri Lanka Insurance *Suba Pathum* scholarship scheme to receive the scholarship.

3.3.4.2 TAXATION

The Company has contributed Rs. 2,451 million (Rs. 3,171 million – 2013) as taxes to the Government in the year 2014 as part of contributing to the society. These taxes include Income Tax, Value Added Taxes, Stamp Duty and Nation Building Taxes etc.

	2014 Rs. '000	2013 Rs. '000	2012 Rs. '000	2011 Rs. '000	2010 Rs. '000	2009 Rs. '000
VAT	1,061,272	1,186,288	1,121,183	1,074,671	816,031	766,018
NBT	252,955	267,011	258,914	299,707	261,317	173,490
WHT		-	-	17,089	44,637	20,613
RSF	9,425	9,751	10,095	8,879	6,374	5,868
ESC		-	-	120,000	120,000	120,000
ST	11,487	8,186	8,175	7,987	5,562	5,417
IT	1,116,126	1,700,039	1,627,413	1,220,547	1,860,560	1,322,893
SRL		-	-	4,803	18,187	25,309
Total	2,451,265	3,171,275	3,025,780	2,753,682	3,132,667	2,439,608

VAT - Value Added Tax NBT - Nation Building Tax WHT - Withholding Tax RSF - Road Safety Fund
 ESC - Economic Service Charge ST - Stamp Duty IT - Income Tax SRL - Social Responsibility Levy

4.0
Corporate Governance

*OUR SUCCESSES
ARE BUILT ON THE ASTUTE
LEADERSHIP WITHIN THE
COMPANY; A COMMITMENT
TO TRANSPARENCY AND
ACCOUNTABILITY; AND AN
ADHERENCE TO COMPLIANCE
BASED ON ESTABLISHED
BEST PRACTICES*

4.1.0 BOARD AT THE HELM OF STEWARDSHIP

As the topmost decision-making body, SLIC has a Board of Directors comprising 06 Directors. They strive to maintain the highest standards of corporate governance as prescribed in the applicable codes for ensuring long-term success of the Company in creating value in the interest of all the stakeholders. Risk management, actuarial valuations, internal audit and system of internal controls strengthen corporate governance standards in SLIC.

Information relating to the Directors including what is required to be disclosed as per the Code of Best Practice on Corporate Governance issued jointly by The Institute of Chartered Accountants of Sri Lanka and the Securities and Exchange Commission of Sri Lanka, June 2008 (available at www.sec.gov.lk) is given below. There were no instances of non-compliance with any of the applicable rules, other than disclosed in Notes to the Financial Statements.

In discharging its duties, the Board has approved an effective business strategy and is driving and monitoring its implementation. A CEO and a management team (as detailed on pages 64 to 67) with the required experience and knowledge to implement the strategy have been appointed. A formal succession plan too is in place. Risk management function was further streamlined during the year (Refer pages 71 to 90). As detailed in the report of the Audit and Compliance Committee on pages 92 to 96, SLIC has an effective system of internal controls. Compliance function ensures compliance with all applicable laws, rules, regulations and ethical standards. Periodic actuarial valuations are undertaken of the life fund and also to determine the policyholders' and shareholders' portion of the surplus. Board ensures adoption of appropriate accounting policies and comprehensive disclosure of financial information.

The number of Board Meetings and Board Subcommittee Meetings held during 2014 and the details of attendance of each Director at these meetings are given below:

BOARD MEETINGS - 2014

Name of the Director	*Total Number of Meetings Attended out of the Total Meetings Held During the Year 2014
Hewa Komanage Upali Dharmadasa	8
Kudabalage Piyadasa	9
Nayana Darshana Prasad Dehigama	8
Sanjay Vishnu Ravindra Samarasinhe	4
Himashe Isuru Balapatabendi	9
Illangamudalige Thamara Kumari Illangamudali (Resigned w.e.f. 07th July 2014)	5
Kalubowilage Mary Anne Nelumani Daulagala (Appointed w.e.f. 07th July 2014)	1

*There were 9 board meetings during the year 2014

AUDIT AND COMPLIANCE COMMITTEE (ACC) MEETINGS - 2014

Name of the Director	*Total Number of Meetings Attended out of the Total Meetings Held During the Year 2014
Himashe Isuru Balapatabendi	4
Illangamudalige Thamara Kumari Illangamudali (Resigned w.e.f. 07th July 2014)	3
Kalubowilage Mary Anne Nelumani Daulagala (Appointed w.e.f. 07th July 2014)	1

*There were 4 meetings of the ACC during the year 2014

HR COMMITTEE MEETINGS - 2014

Name of the Director	*Total Number of Meetings Attended out of the Total Meetings Held During the Year 2014
Hewa Komanage Upali Dharmadasa	0
Nayana Darshana Prasad Dehigama (Appointed w.e.f. 07th July 2014)	7

*There were 7 meetings of the HR Committee during the year 2014

In addition, during the year under review, a Risk Management Committee, which is a formerly constituted committee of the Board of Directors of the Company, was appointed with a broader membership representing different spectrum of risk managers including finance, investments, actuarial, reinsurance, compliance, internal audit, human resources management and ICT etc., details of which are given in the Enterprise Risk Management Report.

Other than the above mentioned three Board subcommittees, Operations Review and Advisory Committee (ORAC) - The Management Committee, Investment Committee, Marketing Committee, TIRRFICS Meeting and Legal Committee consisting of the senior management meet at regular intervals and as and when required to ensure good governance within the Company.

All members of the Board possess extensive knowledge and experience in various facets of financial management and provide financial acumen and balance of the Board.

Board members receive Board papers, agendas and minutes of previous Board meetings well in advance of the Board meetings to be held.

Directors are provided with adequate training opportunities for continuous development and are frequently updated on the latest developments and issues facing the Company and the industry. A summary of Directors' duties has been made available to Directors. Company Secretaries, Varners International (Pvt) Ltd., attend all Board meetings and advise Board members on regulatory and compliance matters and ensure that Board procedures are adhered to.

The Board also carries out an annual appraisal of its members' performance.

4.2.0 BOARD OF DIRECTORS

MR. HEMAKA D.S. AMARASURIYA

Chairman

Respected professional Mr. Amarasuriya is a proud product of Royal College, Colombo and started his career as a dynamic administrator. He was the Chairman and former Managing Director of the Singer Group of Companies in Sri Lanka and the former Chairman of National Development Bank PLC. Mr. Amarasuriya holds Directorships in Bata Shoe Company of Ceylon Ltd., Bata Exports (Pvt) Ltd., ACL Cables PLC, C.W. Mackie PLC, Lanka Aluminium PLC & ACME Printing & Packaging PLC and other non-listed companies as well. He is a former Vice-President of Retail Holdings Limited, USA and of Singer Asia Ltd. and also a former Chairman of the Singer Business Council worldwide.

He is also the founder President of the Industrial Association of Sri Lanka. Currently he serves as the Chairman of Regional Industrial Service Committee (RISC), Southern Province of the Ministry of Industrial Development & Commerce. In addition, he was the former Chairman of The Employers' Federation of Ceylon and has served on the Presidential Task Force on Science & Technology, on the Securities & Exchange Commission and Advisory Committee on Company Law at different times.

He is also the Chairman of Canowin Hotels and Spas (Pvt) Ltd., Canwill Holdings (Pvt) Ltd. Sinolanka Hotels & Spa (Pvt) Ltd. and Helanco Hotels & Spa (Pvt) Ltd. He also serves the boards of Management Services Rakshana (Pvt) Ltd. and Sri Lanka Investments Holdings Ltd.

He is a Fellow of the Institute of Chartered Accountants of Sri Lanka, Fellow of the Chartered Institute of Management Accountants - U.K., Global Chartered Management Accountant and Fellow of the Chartered Institute of Marketing U.K. He holds a Diploma in Marketing Management & Strategy from New York University, U.S.A. His role in the marketing field has been recognised by his appointment as the founder President of the Chartered Institute of Marketing (Sri Lanka Region) and by the 'Asia Retail Congress' with the Retail Leadership Award for his contribution to retailing in Asia and by the Chartered Institute of Marketing UK as a visionary business leader for his invaluable contribution to the marketing profession in initiating revolutionary changes in consumer markets.

He is also an exceptional and unique sporting personality.

MR. T.M.R. BANGSA JAYAH – *Managing Director*



Mr. T.M.R. Bangsa Jayah is a retired commissioned Police Officer, who has experience in the Police service for 29 years. During his career with the Police Department, he has worked as the Chief Security Officer for the Deputy Speaker and North-East Governor.

He is a product of St. Anne's College, Kurunegala and has studied further at Aquinas College, Colombo. During his school period, he has excelled in sports including cricket and soccer. He was a member of the school cadetting team as well. After his schooling, he completed his First-in-Laws at the Law Faculty, Colombo.

Mr. Bangsa has experience in the construction industry for more than 15 years and he has been a principal partner in a well-known piling company. Mr. Jayah serves the Boards of Colombo Dockyard PLC, Ceylon Assets Management Company Ltd., Management Services Rakshana (Pvt) Ltd. and Sri Lanka Investments Holdings Ltd.

MR. P.P.J. PERERA – *Executive Director*



Mr. P.P.J. Perera is a Fellow Member of the Institute of Chartered Accountants of Sri Lanka and holds a Master of Business Administration from the University of Southern Queensland, Australia.

He has well over 30 years experience in Senior Managerial capacity in Sri Lanka Insurance Corporation Ltd. and Sanasa Insurance Company Ltd. In his carrier at Sri Lanka Insurance Corporation Ltd., he has served in the positions of Deputy General Manager/Finance, Deputy General Manager/Support Services and Senior Deputy General Manager (Investments). Whilst in service, he has held Directorships in both Sri Lanka Export Credit Insurance Corporation and Agricultural Insurance Board.

Mr. Perera has also functioned as the Head of Finance, Human Resources and Administration at Sanasa Insurance Company Ltd. and the Chief Executive Officer of Sanasa General Insurance Co. Ltd. He has a wide and diversified experience in the field of finance, investment and the insurance industry in Sri Lanka. Mr. Perera serves the Boards of Ceybank Asset Management Ltd., Ceylon Assets Management Company Ltd., and Management Services Rakshana (Pvt) Ltd.



PROFESSOR LAL GOTABHAYA CHANDRASENA -
Director

Professor Chandrasena is a Clinical Biochemist by profession and counts over 24 years of university academic service and over 22 years experience in hospital and healthcare administration and laboratory sciences. He retired as the foundation Professor of Biochemistry and Clinical Chemistry and Senior Professor of Faculty of Medicine, University of Kelaniya in June 2011 and presently holds the title of Emeritus Professor.

Professor Chandrasena has a Doctorate in Philosophy from the University of Liverpool (U.K.), a Bachelor of Science (Hons) from the University of Liverpool (U.K.); a Fellow of the Institute of Chemistry, Ceylon and is a Chartered Chemist. In addition, he is a Fellow of the Royal Society of Chemistry (U.K.), a Fellow of the National Academy of Sciences of Sri Lanka and Post - Doctoral Fellow, Colorado State University, U.S.A. He is also a Fellow member of the Institute of Certified Professional Managers and holds a certificate in Hospital Administration from the Indian Institute of Management, Ahamadabad. He is the current President of the Association of Private Hospitals, Sri Lanka. He is also a member of the Private Health Services Regulatory Council of the Ministry of Health. He is a Director of Nawaloka Metropolis Clinical Laboratories (Pvt) Ltd. He also serves the Board of Management Services Rakshana (Pvt) Ltd.

MR. IMAL FONSEKA - *Director*



Mr. Fonseka is the CEO of Ceylon Biscuits Ltd. and was the former Managing Director of Hemas Manufacturing, Sri Lanka and the Managing Director of Hemas Consumer Brands, Bangladesh. Previously, he has served in the Boards of Chevron Global Lubricants (Lanka) PLC and Eureka Technology Partners.

He is a graduate of the Chartered Institute of Marketing (UK) and a Certified Management Accountant of Australia whilst completing his postgraduate education at the Indian School of Business. He had his executive education at Kellogg School of Management (Northwestern University), University of Pennsylvania's Wharton School and Fundação Dom Cabral (Brazil). He has extensive experience in advertising, brand management, sales management and general management working with multinationals such as JWT, Unilever, Glaxo-Smithkline and Coca-Cola. He also worked in diverse cultures being posted overseas to manage brands and sales teams in 6 Middle Eastern markets, 3 South East Asian markets and in the subcontinent.

He plays an active role within the marketing fraternity as the past President of the International Advertising Association (Sri Lanka Chapter), founder Chairman of the Sri Lanka Advertising Awards (2006), Chairman of the Sri Lanka Brand Excellence Jury (2007) and as Chairman of the 'EFFIES' Sri Lanka Jury (2009 and 2012) and Chairman of the Trustees of the Sri Lanka Advertising Awards (2010). He also serves the Boards of Sri Lanka Exports Credit Insurance Corporation and Sri Lanka Investments Holdings Ltd.

MR. PRIYANGA ALGAMA - *Director*



Mr. Algama currently serves as the Director General – Department of Public Finance, General Treasury, Ministry of Finance. He holds a Master of Business Administration from the Nanyang Technology (Sing.) University – MIT (USA) and a Bachelor of Commerce (Special) Degree from the University of Kelaniya. He is an Associate Member of CPA Australia (Certified Practising Accountants). He possesses wider experience in systems and procedures of the financial regulation, Government procurement policy framework, Government assets management, project proposals of Government agencies and Corporate Plans etc. He also serves the Board of Management Services Rakshana (Pvt) Ltd., Lanka Electricity Company, Geological Survey and Mines Bureau, Postgraduate Institute of Science, Tourism Development Authority and Construction Guarantee Fund.

4.3.0 SENIOR MANAGEMENT TEAM



Deepthi P. Lokuarachchi
Chief Executive Officer
LLB, Attorney at Law, ACII (UK),
Chartered Insurer
(Appointed w.e.f. 21st April 2014)



Suresh Paranavithana
Chief Officer - Life
FCII, MBA, Dip. M, FCIM, M.I. Mgt,
CMA(Aus)



Ranjith Perera
Senior DGM - Finance
BSc. (Hons) (Pub.Admn.Sp.), MBA, MA,
PG. Dip. in Corp. Finance, FCMA, FCA



Niroshini Pethiyagoda
DGM - Marketing
MBA (MGSM, Syd), FCIM (UK),
Dip. M (UK) Chartered Marketer



Ajith Wijayasundara
DGM - ICT
BSc. (Eng), MBA



Thanuja Hingulage
DGM - General Insurance
BSc. (Hons), FCII (UK),
Chartered Insurer, ANZIIF (Fellow)
(Appointed w.e.f. 3rd November 2014)



Nilanga Wickramasinghe
AGM - National Sales (Life)
PG.Dip. in MGT, CIAM, Dip. LIM,
LUTCF (USA), MCPM, Chartered
Insurance Agency Manager



Rasika Ranatunga
AGM - Facilities Management
Member (ASHRAE) (USA), Member
(ASHRAE) (SL), Dip. HVAC (USA)



Hasantha Perera
AGM - ICT - Governance and Administration
MSc. (IT), MSC (Const. P. Mgmt.), MBA, BSc.
(Eng.), AIPMSL, AIESL, Dip. in Credit Mgmt.
(IBSL)



Dayaratne Perera
AGM - Life (Technical)
BSc. (Hons), FCII, Dip. in BA,
Chartered Insurer, MBA (USJ), AUKAP (UK)



Mahen Peiris
AGM - Legal
LLB (Colombo), Attorney-at-Law of
the Supreme Court of Sri Lanka



Jerome Vincent
AGM - Sales Support
Bcom. (Special - Hons), MBA, Dip. in
Journalism, Dip. in Marketing (UK) MCIM



Nalin Subasinghe
AGM - Actuarial & Risk Management
MSc. in Actuarial Management. (UK),
BSc. (Hons. Mathematics Special), Dip. in
Computer Studies



Dr. Sherica Fernando
AGM - Medical
MBBS (SL), MSc., Community
Medicine (SL), ACII (UK), MRCGP (INT)
(UK) Ad. Dip. in Insurance-CII, Dip. in
Life & Disability Claims



Chaminda Athauda
AGM - Life (Technical)
BSc. (Hons), ACII (UK), AIII, Chartered
Insurer, Senior Associate CIP - ANZIIF
(Senior Associate)



Champa Kannangara
AGM - ICT Systems Development
BSc., MSc. (Comp.Sc.), MBCS



Rodney Wanigasekara
AGM - Internal Audit
BSc. Bus. Admin., FCA(SL), Certified
Public Accountant (USA), MIPA (Aus),
ASA (Aus)



Jeewani Gunawardena
AGM - Internal Audit
FCA, MBA



Namalee Silva
AGM - Marketing & Corporate
Communications
MCIM(UK), Chartered Marketer,
Prof. Dip. in Marketing - CIM, ACIB (UK)



Chaminda Gunasinghe
AGM - Finance
B.B. Mgt. (Accountancy) Spl. Hons,
FCA, ACMA, MBA - Finance



Dhanuka Liyanagamage
AGM - Investments
BSc. (Eng) (Hons), MBA (Finance), CFA,
Member of the CFA Institute (USA) and
CFA Sri Lanka Society



Lalith De Silva
AGM - Motor/Branch Administration
(Cover up)
Postgraduate Dip. In Finance and
Business Administration, MBA



Malaka M. Bandara
AGM - Management Accounting &
Budgetary Control
BSc. - Accountancy (Sp.), ACA,
MBA (Colombo)



Ruwani Dharmawardena

AGM - Compliance and
Assistant Company Secretary
L.L.B. (Hons), Attorney-at-Law, ACISI,
Dip. in Bus. Mgt. (ICFAL), Dip. in Mgt.
(CMA), Dip. in HRM (UK)

Bimal Weerasinghe

AGM - HR
RWP (Retd) BA(Social Sciences),
PG Dip. in International Relations,
Dip in HRM, MIM (SL)
(Appointed w.e.f. 1st August 2014)

4.4.0 ORGANISATIONAL STRUCTURE

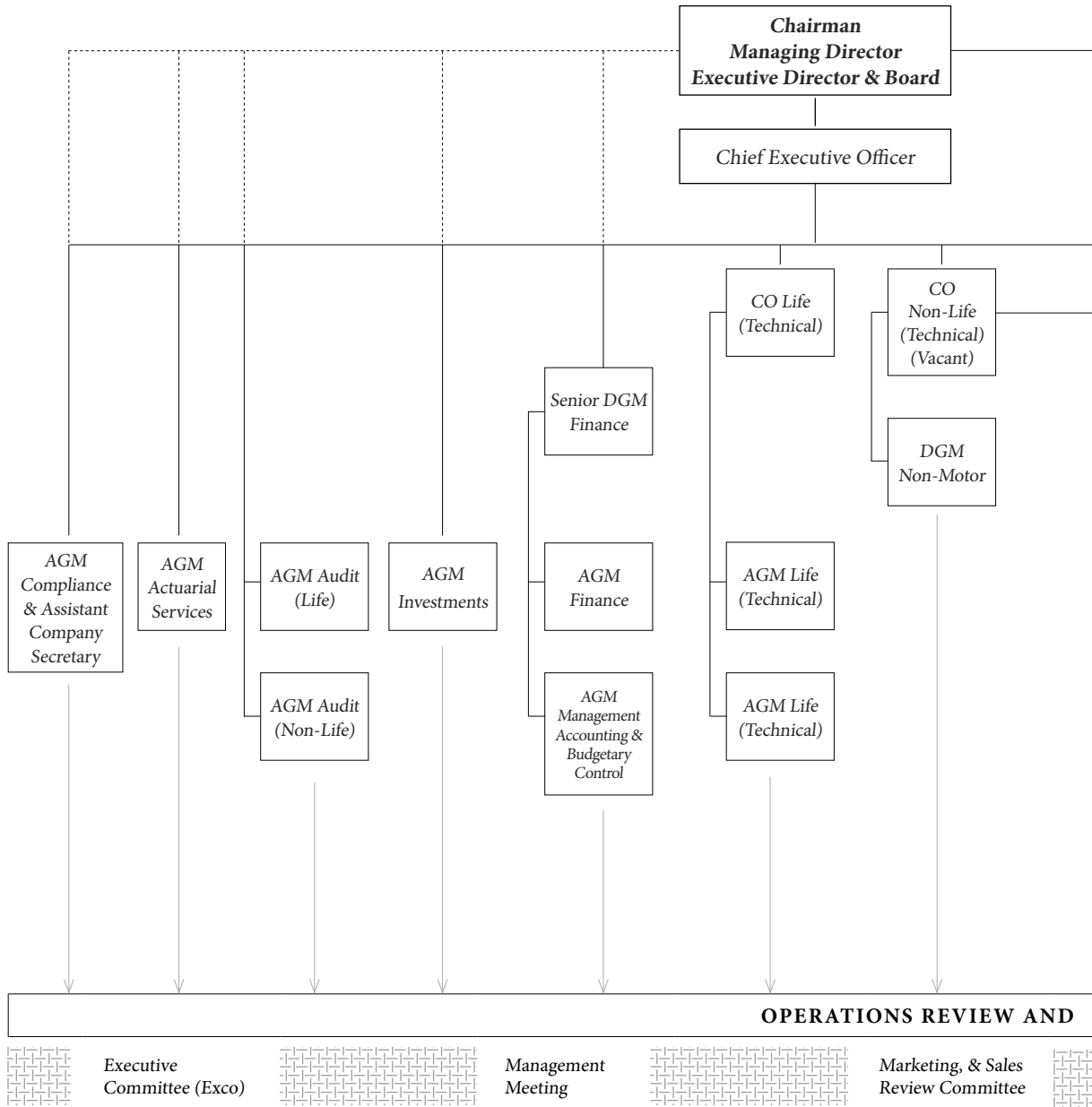

— Hierarchical - - - - Functional *Note: Tiers in the above structure tapers down from CO, Senior DGM, DGM and AGM*

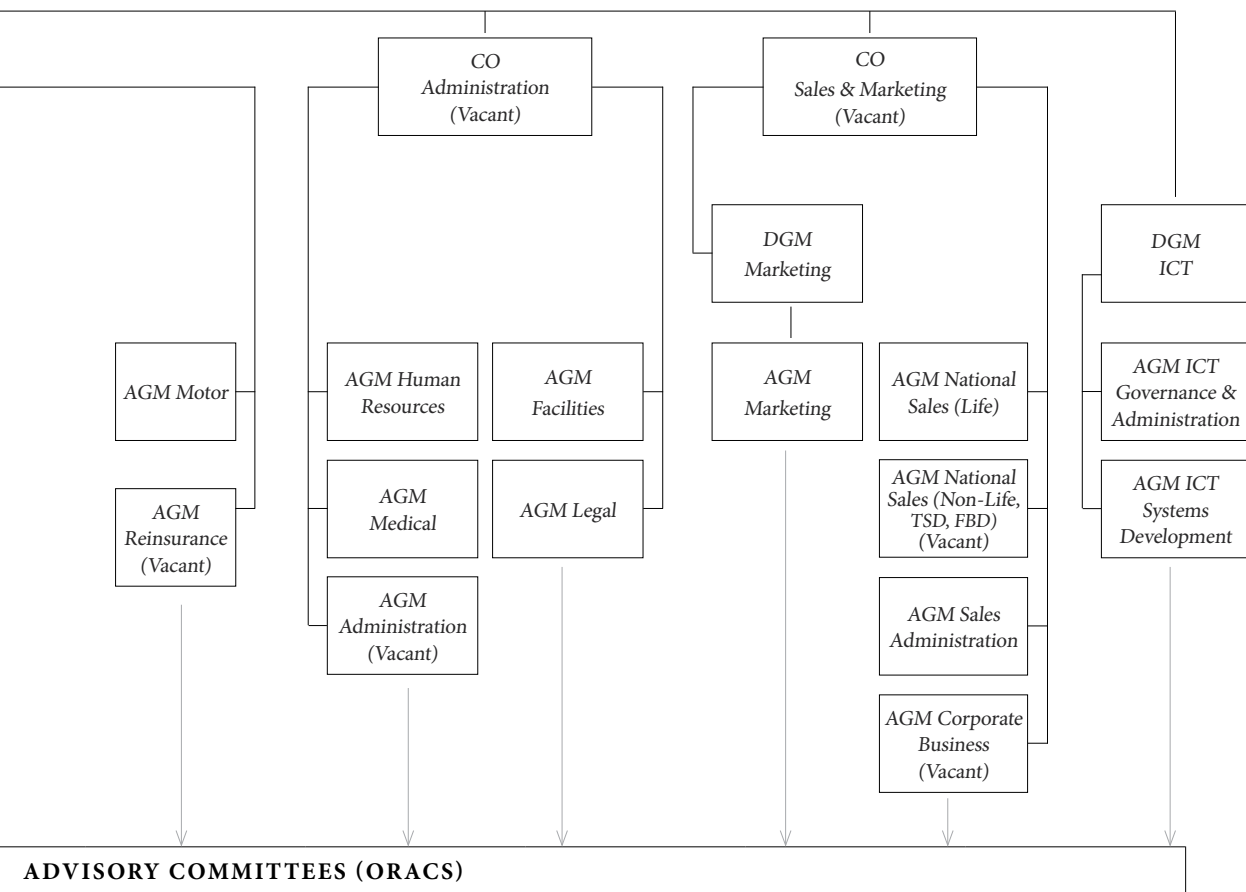
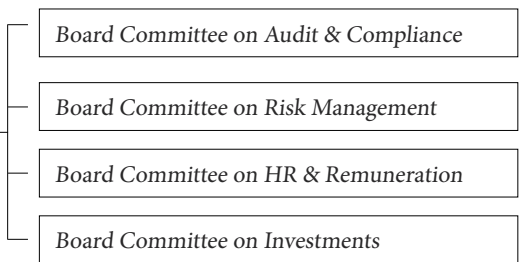

TIRIFICS Committee



Legal Advisory Committee



*OUR WELL STRUCTURED,
BROAD-BASED AND
TRANSPARENT ENTERPRISE
RISK MANAGEMENT
FRAMEWORK HAS FACILITATED
US TO IDENTIFY, MANAGE AND
PREPARE FOR RISKS IN
AN INFORMED MANNER*

INTRODUCTION

Sri Lanka Insurance Corporation Ltd. (SLIC) being the largest composite insurer in Sri Lanka has always given its paramount importance to the risk management function and this is endorsed by stable earnings, improved credit ratings and enhanced shareholder values achieved by the Company over the years: Life insurance business has maintained a solvency ratio of 13.22 and General insurance business, a solvency ratio of 3.80 for the year 2014; SLIC is the only insurer in the country who got the highest financial rating of AAA from Lanka Ratings for its claims paying ability and also SLIC has got the highest financial rating among insurers from Fitch Ratings for its financial strength; and the Net Asset Value of the Company stands at Rs. 64,216 million as at 31st December 2014.

In order to fulfil the requirements of Risk Based Capital (RBC), SLIC is also formulating and centralising its risk management function so as to ensure optimum utilisation of capital within the Company structure. In so far, as the test run is concerned, the results produced up to the end of 2014 are reflective of a position which exceeds the minimum threshold stipulated by the RBC framework.

The following mind map illustrates the main areas of risk management as per the RBC framework:

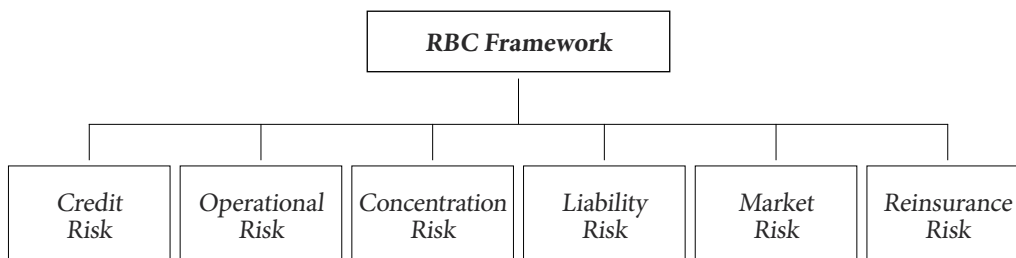

During the year under review, several initiatives were taken to view different types of risks holistically as opposed to independently/silo view and in the right direction. A Risk Management Committee, which is a formally constituted committee of the Board of Directors of the Company has been appointed with a broader membership representing different spectrum of risk managers including finance, investments, actuarial, reinsurance, compliance, internal audit, human resources management and ICT etc. All these departments have embedded ERM into their daily operations.

With a rising focus on risk management throughout highly regulatory sectors, many organisations have concluded that there should be an increasing focus on risk management at Board level. This is consistent with the view that these organisations should have a separate Board level committee overseeing the risk management function, rather than merely relying on internal control systems comprising internal audit, legal or compliance departments.

Due to diverse reasons, to mention a few, growing complexity of risk management function, the increasing number of external guidance sources specifically dealing with risk management and the emergence of risk management as a discipline in its own rights compel for highly regulated large entities such as SLIC for considering a proper segregation of the roles between the Audit and Risk Committees. Accordingly, independently from the Audit and Compliance Committee, the Risk Management Committee oversees the risk management function of the Company. The Risk Management Committee met 05 times during the year under review.

As explained earlier, there is a regulatory driver and a business desire for risk management and the chart below outlines our approach to risk management.



The ensuing paragraphs deal with the risk management function of SLIC. The ERM function is structured based on four broader categories of enterprise risk management covering areas pertaining to Insurance Risks, Investment Risks, Operations Risks and Regulatory Risks.

5.1.0 INSURANCE RISK MANAGEMENT

5.1.1 LIFE INSURANCE RISK

SLIC is a company which has kept to its commitments to its stakeholders for over 53 years in the insurance industry and is a home grown respected and trusted insurance company.

A life insurance company faces risk in relation to its product design, underwriting and claims processes, investment, expenses and human resources. In order to face these risks, the Company has adopted, tried and tested the best risk management practices to identify risk, quantify the impact of risk, develop measures to mitigate risks and to periodically review the risks in the light of changing market and operational conditions. The risk management practices are applied across the Board to product development, underwriting, claims settlement, holistically to underwriting and claims settlement, investment strategy and human resources.

PRODUCT DEVELOPMENT

SLIC provides a basket of insurance products, to cater to the needs of any policyholder and any given stage of their life. The process of life insurance product development goes through a comprehensive risk management process at each stage of product development where risks are identified, the impact of the risks are assessed, the measures to mitigate the risk and minimise the impact of the risk are put in place and the risks are reviewed on a periodic basis. Extensive profit testing in the Model Office environment is the way that SLIC optimises all stakeholders' benefits. The RBC framework is one of the elements in the Profit Testing and Model Office framework.

Life insurance products are developed by a Product Development Committee, comprising representatives of Sales, Marketing, Actuarial and Life Operations. The detailed product development work which includes pricing, sales volume, expenses built in are discussed in detail from a risk management perspective by a multidisciplinary team. All products developed by the Committee are reviewed and approved by the Consultant Actuary and a separate team reviews on a quarterly basis the progress of the selling and distribution of these products to customers.

UNDERWRITING

With regard to risk management in the underwriting process, a team headed by the Assistant General Manager - Life (Technical), who is a Chartered Insurer identifies and analyses the impact of risks associated with the operational risks in the underwriting process which are reviewed periodically in consultation with the team of medical and non-medical underwriters, to identify process improvements and risk mitigation measures on a quarterly basis.

The team visits the branches in order to ensure that the practices adopted by the head office are implemented and controlled accordingly to minimise the operational risks in the underwriting process across the entire head office and island wide branch office network.

CLAIMS

With regard to the risk management in the life claims settlement process, a separate team headed by a different Assistant General Manager - Life (Technical), who is also a Chartered Insurer identifies and analyses the impact of risks associated with the operational risks in the claims process which are reviewed periodically in consultation with the team of claims managers to ensure efficient settlement processes are followed in settling claims. The claims are processed and settled centrally and regular reviews are conducted with the claims managers to discuss the operational risks and issues thereby to ensure departmental efficiency is maintained. Effective mechanisms are in place to track and avoid illegitimate claims.

RISK MANAGEMENT IN BOTH UNDERWRITING AND CLAIMS SETTLEMENT

Every half yearly, the teams comprising of the underwriting managers and claims managers have discussions with the Chief Officer - Life Insurance, where detail operational issues which include operational risks are discussed and solutions and measures to mitigate such risks are developed and adopted to eliminate or minimise the risks that are taken.

INSURANCE LIABILITY RISK MANAGEMENT

Under the SLFRS 4, disclosures pertaining to risk management objectives/policies/methods, sensitivity to insurance risk, concentration of insurance risk and claims development information covering all periods for which material claims are outstanding (5 years approximately) have been required to be made.

LIFE INSURANCE RISK

The risks associated with life insurance include *inter alia*:

- ‘Mortality Risk’ is the risk that actual policyholder death experience on life insurance policies is higher than expected.
- ‘Longevity Risk’ is the risk that annuitants live longer than expected.
- ‘Morbidity Risk’ is the risk that policyholder health related claims are higher than expected.
- ‘Policyholder behaviour Risk’ is the risk that policyholders’ behaviour in discontinuing and reducing contributions or withdrawing benefits prior to the maturity of the contract is worse than expected. Poor persistency rates may lead to fewer policies remaining on the books to defray future fixed expenses and reduce the future positive cash flows from the business written, potentially impacting its ability to recover deferred acquisition expenses.
- ‘Expense Risk’ is the risk that expenses incurred in acquiring and administering policies are higher than expected.

The Company has established procedures and processes to evaluate the above risks which if not properly controlled and managed can impact its operations. The procedures are in place to cover all critical stages from product development to benefit administration.

In addition to that, all life financial streams are modelled and profit testing is produced by the Actuary thus mitigating product design and pricing risk. Also SLIC uses matching instruments to back liabilities (ALM), if available.

SENSITIVITIES ANALYSIS FOR LIFE INSURANCE RISK

Assumptions used in determining life insurance contract liability are tabulated below:

Assumption	Description
Mortality	Guidelines provided by RII Act No. 43 of 2000, which are - - A67/70 for non-annuity business - a(90)m for male annuitants and (90)f for female annuitants
Investment return	Guidelines provided by RII Act No. 43 of 2000, minimum interest used for 31st December 2014 valuation is 3.5% which is consistent with the last 5 years valuation.

The total liability set up under above guidelines is Rs. 60,107 million, excluding cost of bonus.

SLIC participated to ABC parallel run during 2014 and results as at 31st December 2014 are as follows. The total net liability under RBC guidelines for best estimated assumption is Rs. 20,905 million.

Assumption	Change in Assumption	Impact on liability (Rs. million)
Mortality	+10%	785
	-10%	(792)
Investment return	Up shock scenario under RBC	(6,009)
	Down shock scenario under RBC	8,837

CONCENTRATION OF INSURANCE RISK

‘Concentration Risk’ is defined as the risk of exposure to increased losses associated with inadequately diversified portfolios of assets or obligations. Concentration risk for a life insurer may arise with respect to investments in a geographical area, economic sector, individual issuers or due to a concentration of business written within a geographical area, of a policy type or of underlying risks covered.

- From a market risk perspective, although we have invested significantly in the financial sector, our portfolio is diversified and contains huge margins.
- From an insurance risk perspective, the main factors that would affect concentration risk include mortality risk, morbidity risk, longevity risk, policyholder behaviour risk (lapse, anti selection) and expense risk. There is diversification across geographical regions, lines of business and even across the different insurance risk factors such that SLIC is not exposed to significant concentrations of insurance risk.

5.1.2 GENERAL INSURANCE RISK MANAGEMENT

INSURANCE LIABILITY RISK MANAGEMENT

Under the SLFRS 4, disclosures pertaining to risk management objectives/policies/methods, sensitivity to insurance risk, concentration of insurance risk and claims development information covering all periods for which material claims are outstanding (5 years approximately) are required to be made.

GENERAL INSURANCE RISK

'General Insurance Risk' includes the reasonable possibility of significant loss due to uncertainty in the frequency of the occurrence of the insured events as well as in the severity of the resulting claims. Therefore, appropriate mechanisms are in place to manage the premium and claims liability risks which are two aspects of the general insurance risks.

The following provides an overview of the Company's main lines of business:

- Motor includes automobile physical damage, loss of the insured vehicle and automobile third party liability insurance.
- Property includes fire risks (for example fire, explosion and business interruption), natural perils (for example earthquake, windstorm and flood), engineering lines (for example boiler explosion, machinery breakdown and construction) and marine (cargo and hull).
- Liability includes general/public and product liability, excess and umbrella liability, professional liability including medical malpractice and errors and omissions liability.
- Special lines include Directors & officers, credit & surety, crime & fidelity, accident & health and crop.
- Worker injury includes workers' compensation and employers' liability.

The Company's underwriting strategy is to take advantage of the diversification of general insurance risks across industries and geographic regions in which the Company operates. The Company seeks to optimise shareholder value by achieving its mid term return on equity goals. Doing so necessitates a prudent, stable underwriting philosophy that aims to take advantage of its competitive strengths while avoiding risks with disruptive volatility. At the core of the Company's underwriting is a robust governance process.

SENSITIVITIES ANALYSIS FOR GENERAL INSURANCE RISK

The following table shows the sensitivity of net income before tax and the sensitivity of net assets, as a result of adverse development in the reported claims outstanding by one percentage point. Such an increase could arise from either higher frequency of the occurrence of the insured events or from an increase in the severity of resulting claims or from a combination of frequency and severity. The sensitivities do not indicate a probability of such an event and do not consider any non-linear effects of reinsurance. Based on the assumptions applied in the presentation of the sensitivity analysis in the table below, each additional percentage point

increases in the reported claims outstanding would lead to a linear impact on net income before tax and net assets. In addition, the Company monitors insurance risk by evaluating extreme scenarios, taking into account non-linear effects of reinsurance contracts.

	Change in Assumptions	Reported Gross Claim Outstanding Rs.	Reported Net Claim Outstanding Rs.	Impact on Gross Liabilities Rs.	Impact on Net Liabilities Rs.	Impact on Profit Before Tax Rs.	Impact on Equity Rs.
31.12.2014	+1%	5,526,494,072	4,626,783,671	55,264,941	46,267,837	(46,267,837)	(33,312,842)

CONCENTRATION OF INSURANCE RISK

In addition to the specific risks insured, each line of business could expose the Company to losses that could arise from natural and man-made catastrophes. The main concentrations of risks arising from such potential catastrophes are regularly reported to the senior management.

The table below shows the Company's concentration of risk within the General Insurance business by line of business based on direct written premiums before reinsurance and after reinsurance.

Class	GWP Rs. '000	Reinsurance Rs. '000	NWP Rs. '000	% of NWP
Motor	7,205,255	164,882	7,040,373	71.58
Fire	1,553,151	1,394,799	158,352	1.61
Marine	402,134	280,134	121,704	1.24
Other	3,384,285	868,905	2,515,380	25.57
	12,544,825	2,709,016	9,835,809	100.00

CLAIMS DEVELOPMENT INFORMATION

Table below presents changes in the historical non-life reserves, net of reinsurance. The top line of the table shows the estimated gross reserves for unpaid losses and loss adjustment expenses as of each reporting date, which represents the estimated amount of future payments for losses incurred in that year and in prior years. The cumulative paid portion of the table presents the cumulative amounts paid through each subsequent year in respect of the reserves established at each year end. Similarly, the cumulative reported losses section details the sum of the cumulative paid amounts shown in the triangle below and the net outstanding position at the end of the financial year.

As at 31st December	2010 Rs.	2011 Rs.	2012 Rs.	2013 Rs.	2014 Rs.
Gross reserves for losses and loss adjustment expenses	6,759,172,132	7,898,096,692	8,720,582,620	7,817,800,636	7,709,470,517
Reinsurance recoverable	(1,361,271,745)	(1,168,930,136)	(1,509,187,974)	(1,160,448,524)	(1,004,432,194)
Net reserves for losses and loss adjustment expenses	5,397,900,387	6,729,166,557	7,211,394,645	6,657,352,112	6,705,038,323

Cumulative paid as of 31st December:

One year later	2,874,874,128	3,632,757,028	4,545,085,355	4,481,213,520	4,572,092,748
Two years later	3,714,910,249	4,903,405,392	5,908,837,239	5,873,385,629	
Three years later	3,788,276,570	4,980,092,970	6,016,063,272		
Four years later	3,806,053,537	5,014,506,148			
Five years later	3,832,694,904				

Cumulative Reported as of 31st December:

One year later	3,877,357,626	4,740,384,794	5,765,263,148	5,564,838,084	5,631,797,127
Two years later	4,091,340,643	5,147,257,128	6,199,143,542	6,107,020,752	
Three years later	4,020,496,575	5,195,146,471	6,287,566,401		
Four years later	3,995,269,295	5,289,158,538			
Five years later	4,110,863,857				

5.2.0 INVESTMENT RISK MANAGEMENT

Investment risk management is of paramount importance in the current turbulent markets characterised by high volatility of asset returns, reduced diversification benefits due to high correlations and wider dispersion in market sentiments and views.

The aim of the risk management at SLIC is to promptly identify, measure, manage, report and monitor risks that affect the achievement of investment objectives. This includes taking, avoiding, mitigating and adjusting the risk profile to maintain the appropriate balance among asset growth as well as income to meet the obligations of the Fund, based on prudent risk management principles within the context of applicable IBSL insurance regulations.

5.2.1 INTEREST RATE RISK

Interest rate risk is the risk of loss resulting from changes in interest rates, including changes in the shape of yield curves while credit spread risk describes the sensitivity of the values of assets and liabilities due to changes in the level or the volatility of credit spreads over the risk-free interest rate yield curve.

Interest rate risk is managed over each major maturity bucket and adherence to the aggregated positions with risk limits.

Key policy rates, i.e. Standing Lending Rate and Standing Deposit Rate remained unchanged during the year and maintained at 8.00% and 6.50% respectively, showing the intention of the Central Bank of Sri Lanka to keep it low. Further, Treasury Bill Rate saw a steep decline during the year with the benchmark 364 day rate falling from 8.29% to 6.00% during the year. With inflation under control and Government curtailing its local borrowings, the interest rates are expected to remain low in the short to medium-term.

The lack of long-term Fixed Income instruments, yielding acceptable level of returns has brought in an Asset-Liability Duration mismatch for the Life Fund. However, having analysed the situation, the Investment Committee proactively lengthened the duration of the Fixed Income portfolio by investing in some long-term instruments, which yielded attractive returns as well, mitigating the pressure on interest income, while closely monitoring the duration mismatches.

1-Year T-Bill Rate

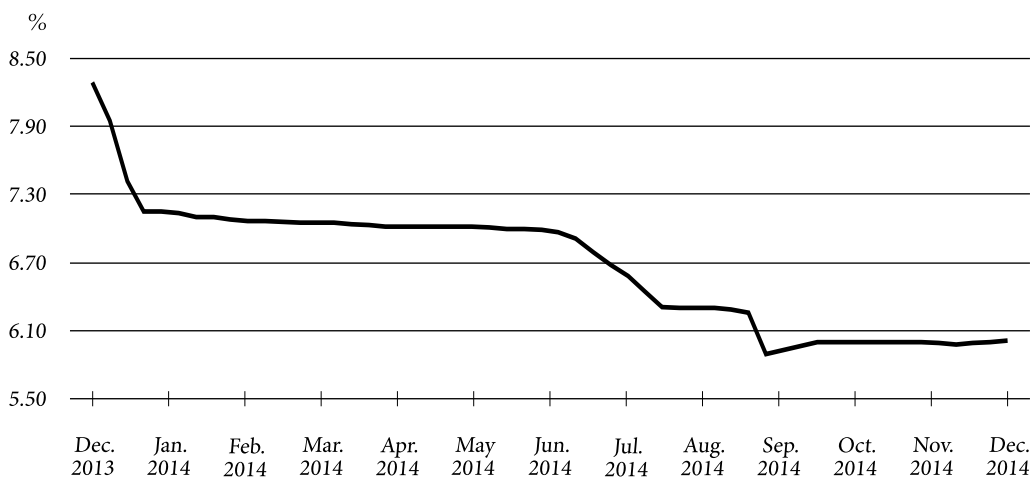

Maturity Profile – Life Fund

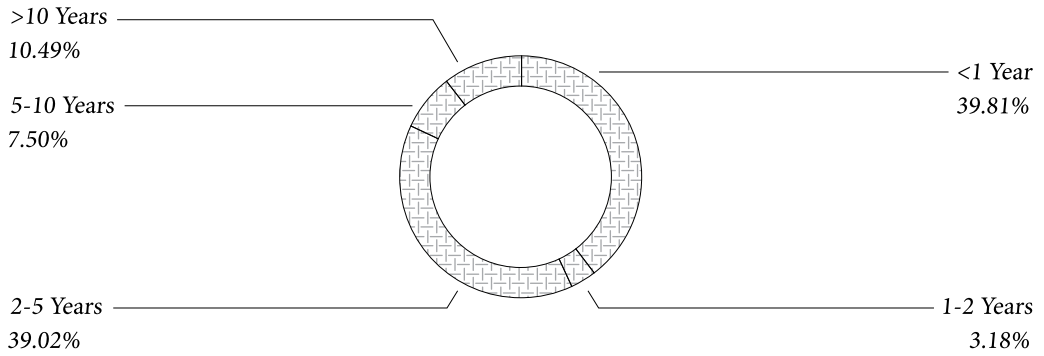

Maturity Profile – General Fund

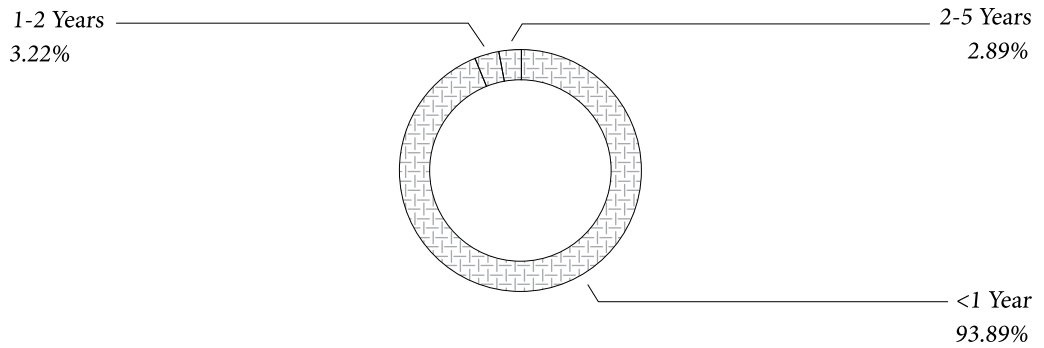

5.2.2 MARKET RISK

Market Risk is the risk incurred by the Equity portfolio due to the volatility of the stock prices.

SLIC mitigates market risk by diversifying the equity portfolio into different sectors and companies.

The equity market, rebound in 2014 with a significant 23.44% gain. As valuations of some key counters seem attractive, expectations remain bullish in 2015 as well. This will be further supported by the low interest rates and inflation which will divert the investors to extend their positions more towards equities.

All Share Price Index

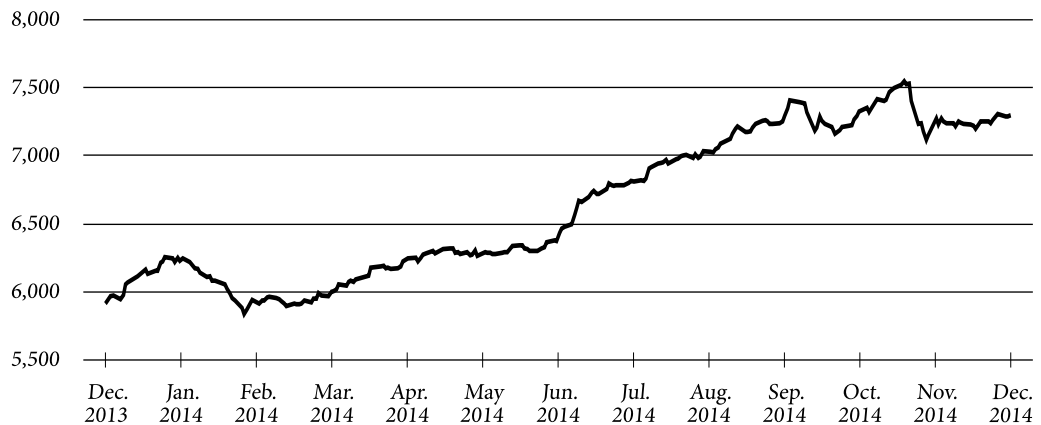

The Colombo Stock Exchange continued to attract foreign investors with a net foreign inflow of Rs. 8 billion during the year, albeit significantly lower than the previous year's figure of Rs. 33 billion. Interest in fundamentally strong counters, particularly blue-chips, has remained buoyant as foreign investments have flowed steadily into these counters.

Sector Allocation – Listed Equity - Life Fund

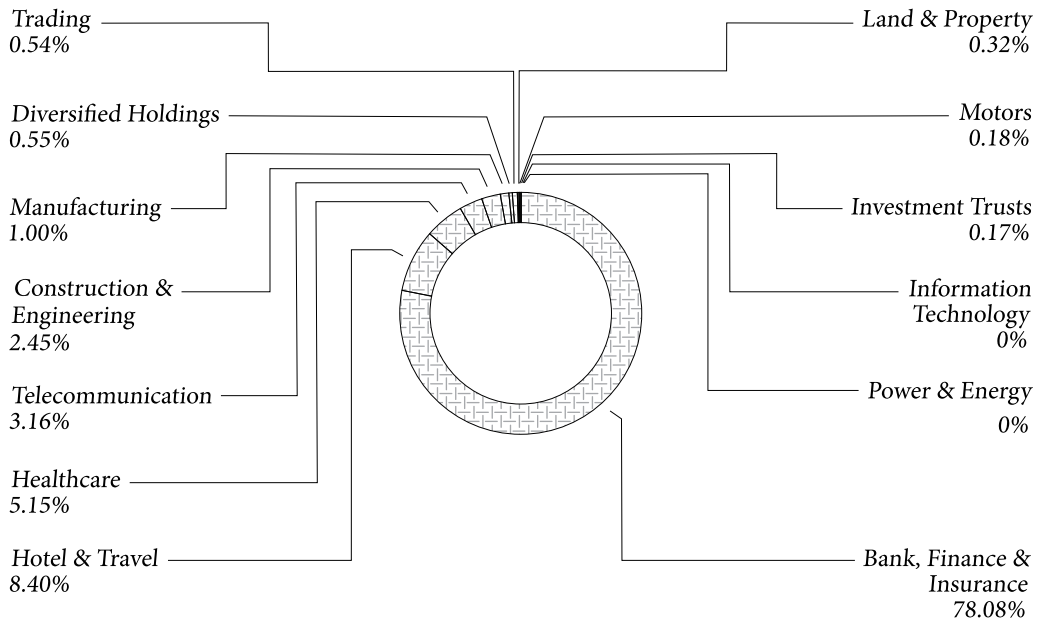

* Including The Lanka Hospitals Corporation PLC which is a Subsidiary of SLIC.

Sector Allocation – Listed Equity - General Fund

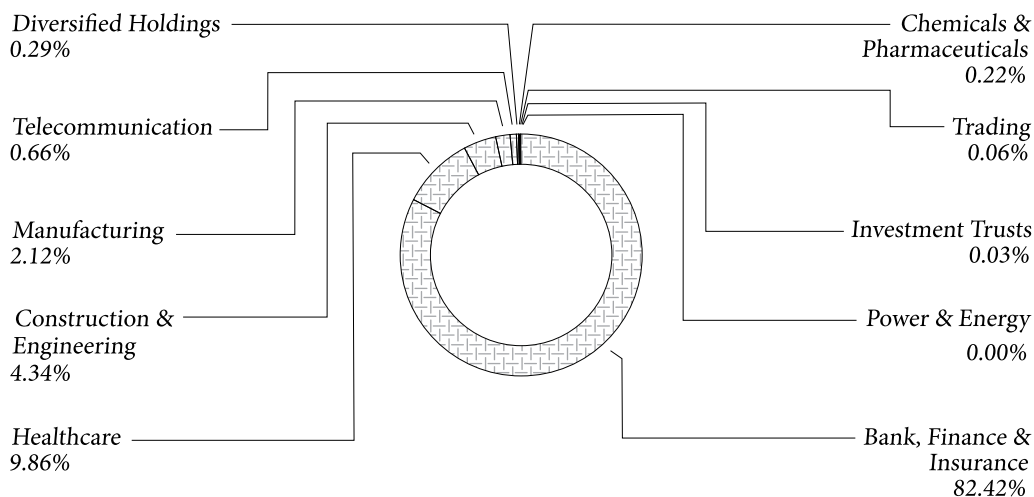

* Including The Lanka Hospitals Corporation PLC which is a Subsidiary of SLIC.

5.2.3 CREDIT RISK & CONCENTRATION RISK

Credit risk is the risk associated with a loss or potential loss from counterparties failing to fulfill their financial obligations.

Credit risk is monitored and managed at each borrower's level, as well as at the portfolio level in order to ensure a well balanced portfolio, with a view to limiting concentrations in terms of risk quality, industry, maturity and large exposure.

SLIC has established its own limits on concentration in investments by single issuers and certain asset classes and also limits investments in illiquid instruments.

- No investment has been made in Term Deposits other than in Licensed Commercial Banks and Licensed Specialised Banks.
- Investment grade credit rating for both entity and instrument by a recognised credit rating agency is expected for all investments in Corporate Debentures and Commercial Papers.
- No debt investment has been made in any of the Related Companies.
- A comprehensive credit analysis is carried out internally prior to making any investment in a debt security.

5.2.4 LIQUIDITY RISK

Liquidity risk is the risk that the SLIC does not have sufficient liquidity to meet its obligations when they fall due or would have to incur excessive costs to do so.

5.2.4.1 LIFE FUND

Traditionally, it is the fund needing minimal liquidity. Annual cash inflows from premium income and others have exceeded cash outflows. This reflects the growing volume of business, the longer term nature of liabilities and the rollover in portfolio assets from maturing securities and other forms of principal payments.

However, in upcoming years, greater than historical volumes of maturities and cash outflows are expected representative of a new phase in the fund's policy maturity cycle. Treasury bonds may be used to match these anticipated exceptional cash outflows by coinciding maturities.

Short-term allocation included a funding cushion of over Rs. 2.7 billion in liquid securities to meet policy obligations, tax obligations and investment opportunities.

5.2.4.2 GENERAL FUND

Because of the uncertainty of cash outflows, liquidity remained an essential consideration for the General Fund. It was important for the fund to maintain a portfolio of short-term securities, as an immediate liquidity reserve.

The fund also maintains a portfolio of readily marketable Treasury Bonds, together with a laddered maturity schedule and matching asset maturities against seasonal cash flow requirements (if appropriate).

5.3.0 OPERATIONAL RISK

Operational risk is the risk associated with people, processes and systems of SLIC.

With the implementation of SAP Treasury Module, the Operational Risk was all but eliminated. With this pilot project being successful, the implementation of the fully pledged SAP Financial Module is to be completed in 2015.

5.3.1 ICT RISK

Information Communication Technology related risk profile was built and in the process of addressing all identified ICT risks. Special attention is given to the IT Security, Management Information and ICT Operational related risk areas.

Building a comprehensive Business Continuity Plan (BCP) and Information Technology Disaster Recovery Plan (IT/DRP) are the identified major activities during the year 2014/15. SLIC established a comprehensive online IT Disaster Recovery (DR) site to facilitate proper business continuity and recovery planning. In addition to the above, major focus is given to mitigate continuous network and perimeter level related risks.

5.3.2 REPUTATIONAL RISK

'Reputational Risk' is defined as the risk arising from negative perception on the part of customers, shareholders, investors or regulators that can unfavourably affect the Company's capacity to uphold existing or establish new, business relationships is monitored. Mainly the responsibility for the identification, escalation and resolution of reputational risk issues resides with the businesses. The responsibility of control groups such as compliance, legal and internal controls is to ascertain that such issues have been suitably identified, escalated and resolved by the business. The Company has a sound system of internal controls to ensure that the reputation risk is mitigated. The Company is committed to comply with all applicable laws, rules & regulations and company policies.

5.3.3 RISK IN FRAUD AND MISCONDUCT

Corporate Fraud and Misconduct remain a constant threat to public trust and confidence and the Company is aware of importance of anti-fraud measures to address the risk. Presently, the Company has effective fraud management systems in place across its operations which provide SLIC with tools to manage risks in a manner consistent with the regulatory requirements as well as the entity's business needs and customer expectations.

The Company's Internal Audit function acts as one of the key functions in anti-fraud activities, supporting management's approach to preventing, detecting and responding to fraud and misconduct. Further, Compliance Department gives immense contribution towards implementing anti-fraud laws and regulations into internal control systems and conducts regular awareness training programs. Both internal audit and compliance functions do report independent views of Company's risk management of fraud and misconduct with their recommendations and preventive measures to the Audit and Compliance Committee.

Effective mechanisms are in place to track and avoid illegitimate claims in Life and General Insurance business. The claim and underwriting processes are backed by an internal independent Investigation Department with specialised team of senior officials and the Company seeks external professional expertise's services as and when appropriate.

SLIC has laid down procedures formally to respond and take corrective actions for detected frauds through well qualified internal and external inquiry and prosecution officials monitored by the HR Department.

5.3.4 HUMAN RESOURCES (HR) RISK

Though traditionally risk specialists have paid little attention to human resources and human resources calamities in the recent past human resources management has gained its recognition on ERM. HR plays a dual role in risk management: first people are a source of risk due to diverse reasons like shortage of skilled people and key employees leaving the organisations etc., and secondly people are important in managing risks.

HR risk management is important from the perspective of strategic risk (e.g. overreaching human capital strategy), operational risk (e.g. gaps in talent supply and demand), financial risk (e.g. delayed services and compensation etc.) and other risks including compliance (e.g. unions and health and safety etc.) and reputational risk, as depicted below:

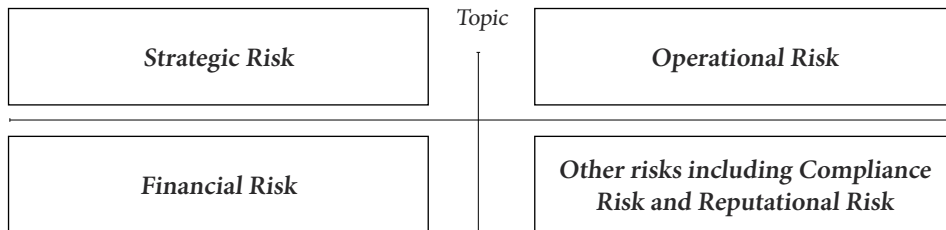

Below it is discussed the challenges encountered by the HR Department in managing HR risk and its impact on business results.

A. RETAINING TALENT

Retaining the best talent is of paramount importance to be in cutting edge in the industry. When recruiting new staff, techniques such as aptitude tests, language tests, and assessment centres and scenario analysis would be in place in addition to panel interview. This would ensure that candidate's knowledge, skills and attitudes are systematically evaluated.

Turnover will be reduced if employees are able to continue their professional growth within the organisation. HR has identified the need of introducing an effective performance evaluation system and an employee recognition plan to motivate and retain key performers by providing training opportunities to further enhance their knowledge and skills.

B. MAINTAINING INDUSTRIAL PEACE

Identifying the importance of industrial peace, the management has entered into collective agreements with the two main trade unions in order to maintain a cordial relationship with the employees.

C. STAFF GRIEVANCES

By appointing committees for staff promotions, transfers and grievances the Company was able to handle staff burdens which were a massive challenge to the HR Department.

Every employee at SLIC was given an opportunity to apply for promotions annually based on the criteria stipulated in the annual promotion policy. Moving away from the traditional promotion methodologies we ensure that employee's knowledge, skills and attitudes are systematically evaluated during the promotion process.

D. DEPARTMENT STRUCTURING AND RESTRUCTURING PROJECTS

Departmental restructuring processes are carried out to identify areas for improvement and further the work processes are being streamlined to be in par with industry changes.

5.3.5 HEALTH AND SAFETY RISK

With regard to the 'health and safety risk', as a minimum, we comply with all local health and safety legislation but will go beyond those requirements should it be necessary to do so in order to deliver the corporate objectives of the Company.

5.3.6 OPERATIONAL RISK PERTAINING TO INVESTMENTS

With the implementation of SAP Treasury Module, the operational risk was all but eliminated. With this pilot project being successful, the fully-fledged SAP Financial Module is planned to be implemented in 2014.

5.4.0 REGULATORY RISK MANAGEMENT

The latest view is that for highly regulated businesses like insurance, compliance programmes can no longer just be 'adequate' rather the expectation is that the Company commits the appropriate talent and resources to compliance management solutions and to establish and maintain a 'strong' culture of compliance and ethics. Consequently, the insurance industry is now looking at an integrated Governance, Risk and Compliance (GRC) process and architecture for addressing the changing business environment. At SLIC the Compliance Department having valuable resources consisting of a lawyer and two chartered accountants ensures compliance with applicable laws, rules, regulations and principles of good governance in line with the said premise of GRC.

Regulatory risk brings in certain costs and risks including the risk of non-compliance and the risk of introduction of new laws, rules and regulations or changes to the existing laws, rules and regulations. The latest and prominent examples of regulatory changes which had major implications for insurers include the introduction of the new amendment to the Insurance Industry Act No. 43 of 2000.

The risk-based capital framework has been introduced to the insurance industry to protect the interest of the stakeholders and minimise the risk of failure of the industry. All insurers are proposed to transition by 2017 for Risk Based Capital Regime. The Company has been reporting under both Solvency Rules and RBC Rules during the parallel run period from March 2014 onwards.

In the insurance industry, it has been made mandatory by the Regulation of Insurance Industry (Amendment) Act No. 3 of 2011 (RII 2011) for the existing insurers to segregate their long-term (LTIB) and general insurance (GIB) into two separate companies within 4 years from 2011 and accordingly to be listed within 5 years from 2011. The Company is working on the said segregation process to achieve its purpose efficiently. A committee representing different spectrum of senior managers has been appointed to address the matters pertaining to the said segregation.

SLIC is equipped with a comprehensive compliance framework. 'Compliance programme' designed for the use of the staff and management is available in the 'compliance web page' on the Company intranet for which internal staff has access from their individual computers. The main objectives of the 'compliance web page' are 'identification, documentation and communication (basically through Company intranet and Lotus Notes) of up-to-date information about the relevant statutory, regulatory compliance obligations to the staff and management.

Plethora of laws, rules and regulations, to mention a few, the Companies Act No. 07 of 2007, Inland Revenue Act No. 10 of 2006 as amended, Electronic Transactions Act No. 19 of 2006, Intellectual Property Act No. 36 of 2003 and Arbitration Act No. 11 of 1995 are applicable for the insurance industry and the said laws have been captured and available in the compliance web page. Effective compliance risk management is a collaborative process that pulls together and leverages all the diverse control function within the organisation such as risk management, internal control, legal and human resources etc.

At SLIC, the Compliance Department has identified the divisional responsibilities pertaining to the applicable laws, rules and regulations and implements a collaborative process in meeting compliance requirements.

As a proactive measure, the Compliance Department guides the management on anticipated regulations of the future, since a proactive business process management solution will provide the Company with the necessary tools to address new regulations cost-effectively.

Further, we have identified the risk of anti-money laundering (AML) and the Compliance Department has educated the staff on the importance of combating money laundering when selling insurance products. In addition, the AML function was audited by the Internal Audit Department during the year under review in line with the AML laws, rules and regulations.

In addition, various compliance regulations in the insurance industry require the senior management and other stakeholders to be trained on compliance requirements. The Compliance Department conducts trainings on department-wise and also educates the senior management by way of 'Compliance Tips' through the internal communication platforms. The Company is working on enhancing its information technology infrastructure and in future that would facilitate the utilisation of skilled compliance capital to focus on compliance management more efficiently.

*OUR AUDIT AND COMPLIANCE
COMMITTEE (ACC)
ENSURES THAT STRICT
COMPLIANCE MECHANISMS
ARE IN PLACE, WHICH ARE IN
ADHERENCE TO THE RELEVANT
LAWS & REGULATIONS
AND ACCEPTED BEST
PRACTICES*

During 2014, the Audit and Compliance Committee (ACC) comprised of two Non-Executive Directors; namely, Ms. I.T.K. Illangamudali (Treasury Representative on Board) and Mr. H.I. Balapatabendi. However, Ms. I.T.K. Illangamudali resigned w.e.f. 07th July 2014 and Ms. Kalubowilage Mary Anne Nelumani Daulagala (subsequent Treasury Representative on Board) was appointed w.e.f. 07th July 2014. With the change of Directors on 20th January 2015, the ACC was reconstituted on 19th February 2015 to be Chaired by the Treasury Representative on Board - Mr. P. Algama along with the Non-Executive Director, Professor Lal Gothabaya Chandrasena as a member. In addition the Managing Director of the Company, Mr. T.M.R. Bangsa Jayah attends ACCM along with the following senior managers: Chief Executive Officer, Chief Officer-Life, Senior Deputy General Manager – Finance, Deputy General Manager - ICT, two Assistant General Managers - Internal Audit and Assistant General Manager - Compliance. In addition, as and when required, other members of the senior management also attend ACCMs.

The Engagement Partner and the Audit Team Manager of the Company's External Auditors, Messrs KPMG, too attend meetings on the invitation of the Committee. Messrs Varners International (Pvt) Ltd. acts as the Secretary of the meetings.

The Committee, with the valuable services provided by the senior support staff, has an adequate blend of financial and insurance expertise in order to carry out the ACC's duties effectively.

6.1.0 TERMS OF REFERENCE

The terms of reference of the Audit and Compliance Committee of SLIC are clearly defined in the Charter of the Board's Audit and Compliance Committee, which is based on the guiding principles and best practices on Audit Committees including the 'Code of Best Practice on Corporate Governance' jointly issued by the Securities and Exchange Commission of Sri Lanka ('SEC') and The Institute of Chartered Accountants of Sri Lanka, 2008. The Committee is responsible to the Board of Directors and reports its activities regularly to the Board.

6.2.0 MEETINGS OF THE COMMITTEE

During the financial year ended 31st December 2014, 4 meetings of the committee were held. The proceedings of the Committee meetings are recorded with adequate details and are reported regularly to the Board of Directors. The attendance of the committee members at the meeting is stated below. On the invitation of the Committee, the Engagement Partner of the Company's external Auditors Messrs KPMG, attended one committee meeting during the year.

6.3.0 COMPOSITION OF THE ACCM AS AT 31ST DECEMBER 2014

	Total number of meetings attended out of the total meetings held during the year 2014
Himashe Isuru Balapatabendi	4
Illangamudalige Thamara Kumari Illangamudali (resigned w.e.f. 07th July 2014)	3
Kalubowilage Mary Anne Nelumani Daulagala (appointed w.e.f. 07th July 2014)	1

Mr. H.I. Balapatabendi and Ms. K.M.A.N. Daulagala ceased to be Directors w.e.f. 20th January 2015. The Treasury Representative on Board, Mr. Priyanga Algama was appointed as the Chairman of the ACC, w.e.f. 19th February 2015.

6.4.0 ROLE OF THE AUDIT AND COMPLIANCE COMMITTEE

The ACC continues to assist the Board of Directors in fulfilling effectively its responsibilities relating to financial and other connected affairs of the Company. The Committee has been empowered to:

1. Ensuring that a good financial reporting system is in place in order to give accurate, appropriate and timely information to the management, regulatory authorities and the shareholders in compliance with the Companies Act No. 07 of 2007, Sri Lanka Accounting Standards (SLAS), Regulation of Insurance Industry Act No. 43 of 2000 as amended and Statement of Recommended Accounting Practice - ICASL etc.

2. Ensuring that appropriate plans, internal controls and procedures are in place and monitoring the Internal and External Audit Programme, reviewing the Internal and External Audit/ Inspection Reports, following up their findings and recommendations.
3. Ensuring that the strategies, plans, manning and organisation for internal auditing and the methodologies promulgated as best practice are carried out.
4. Reviewing the suitability and the quality of accounting policies and any changes in accounting policies and practices and their adherence to statutory and regulatory compliance and applicable accounting standards.
5. Carrying out appropriate investigations to mitigate the fraud risk.
6. Ensuring compliance with applicable laws, rules and regulations etc. and principles of good governance.

6.5.0 INTERNAL AUDIT

The Company has its own Internal Audit Department. Internal Audit Department is headed by two qualified Chartered Accountants. The internal audit programme was presented and approved by the ACC and Committee regularly reviews and monitors the internal audit and the inspection function.

6.6.0 EXTERNAL AUDIT

The ACC reviews the audit and non-audit services provided by the External Auditors to ensure that such services do not impair the independence of the External Auditors.

The ACC has noted the declaration dated 28th January 2015 from Messrs. KPMG, as required by the Companies Act No. 07 of 2007, confirming that they do not have any relationship or interest in the Company, which may have a bearing on their independence within the meaning of the Code of Conduct and Ethics of The Institute of Chartered Accountants of Sri Lanka.

The ACC has recommended to the Board of Directors that Messrs KPMG be reappointed as Auditors for the financial year ended 31st December 2015 at the next Annual General Meeting, subject to the change of the audit partner in line with the principles of good governance. The ACC recommends the fees payable to the statutory auditors for approval.

The Management Letter together with the Management's responses thereto and Annual Accounts were reviewed with the Auditors.

6.7.0 COMPLIANCE FUNCTION

The compliance programme of the Company is implemented by the Senior Deputy General Manager – Finance, Assistant General Manager – Compliance and Senior Manager – Finance, with the assistance of the compliance coordinators in each department. The compliance responsibilities relating to operational areas are carried out by the heads of the operational departments designated as the responsible officers for ensuring compliance with specific obligations assigned to them.

6.8.0 NON-AUDIT SERVICES

Non-audit services amounting to Rs. 12,642,594/- were provided by the External Auditors during the year under review.

6.9.0 GOOD GOVERNANCE

The Committee monitored on a continuous basis, the maintenance of the highest standards in Corporate Good Governance. All staff have been encouraged to resort to whistle-blowing in the strictest confidence, when they suspect wrong doings or other improprieties. Appropriate procedures are in place to conduct independent investigations into all such reported incidents. Staff have been assured of maintenance of strict confidentiality of the identity of whistle-blowers.

6.10.0 CONCLUSION

The ACC is satisfied that the Company's internal controls are effectively implemented and the Company's assets are sufficiently safeguarded. The Committee is satisfied that the internal audit department and External Auditors have been effective and independent throughout the year. In addition, the Committee is also satisfied with the appropriateness of application of the accounting policies and thus gives a reasonable assurance that the Financial Statements of the Company are reliable. Further, the Committee is satisfied that the Compliance Framework of the Company ensures that the Company complies with all applicable laws, rules and regulations and corrective and preventive actions were taken with regard to the reported non-compliances, during the year under review.

The ACC approved this report on 21st May 2015.

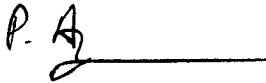
A handwritten signature in black ink, appearing to read 'P. Algama', is written over a solid horizontal line.

Mr. P. Algama

Chairman

Audit and Compliance Committee

1st June 2015

7.0
Financial Reports

*OUR FINANCIAL STATEMENTS
AND CORRESPONDING
NOTES, OUTLINE THE
PERFORMANCE AND GROWTH
ACHIEVED BY BOTH THE
GROUP AND THE COMPANY
DURING THE YEAR*

CONTENTS

7.0. Financial Reports	97 – 254
7.1.0 Annual Report of the Board of Directors of the Company	99
7.2.0 Statement of Directors’ Responsibility	107
7.3.0 Chief Executive Officer’s and Chief Financial Officer’s Responsibility Statement	108
7.4.0 Certificate of Actuary of the Insurer	110
7.5.0 Liability Adequacy Test	111
7.6.0 Certification of Incurred But Not (Enough) Reported Claims	112
7.7.0 Independent Auditors’ Report	113
7.8.0 Statement of Financial Position	116
7.9.0 Statements of Profit or Loss and Other Comprehensive Income	118
7.10.0 Statement of Changes in Equity	120
7.11.0 Statements of Cash Flows	124
7.12.0 Segmental Review: Statement of Income	126
7.13.0 Segmental Review: Statement of Financial Position	130
7.14.0 Notes to the Financial Statements	134

7.1.0 ANNUAL REPORT OF THE BOARD OF DIRECTORS OF THE COMPANY

1. GENERAL

The Board of Directors of the Company has pleasure in presenting their Annual Report to the members together with the Audited Financial Statements for the year ended 31st December 2014 of the Company and the Group and the Auditor's Report on those Financial Statements confirming the requirements of the Companies Act No. 07 of 2007, Regulation of Insurance Industry Act No. 43 of 2000 and Sri Lanka Accounting and Auditing Standards Act No. 15 of 1995 and amendments made thereon.

As at 31st December 2014, 99.97% shares are vested with the Secretary to the Treasury on behalf of the Government of Sri Lanka.

Litro Gas Terminal Lanka (Pvt) Ltd., Canowin Hotels and Spas (Pvt) Ltd. and Management Services Rakshana (Pvt) Ltd. are fully-owned subsidiaries of the Company. The SLIC has 99.94% shareholding of Litro Gas Lanka Ltd. and 54.61% shareholding of The Lanka Hospitals Corporation PLC. SLIC has 45.95% shareholding of Canwill Holdings (Pvt) Ltd. The Group structure is as given below:

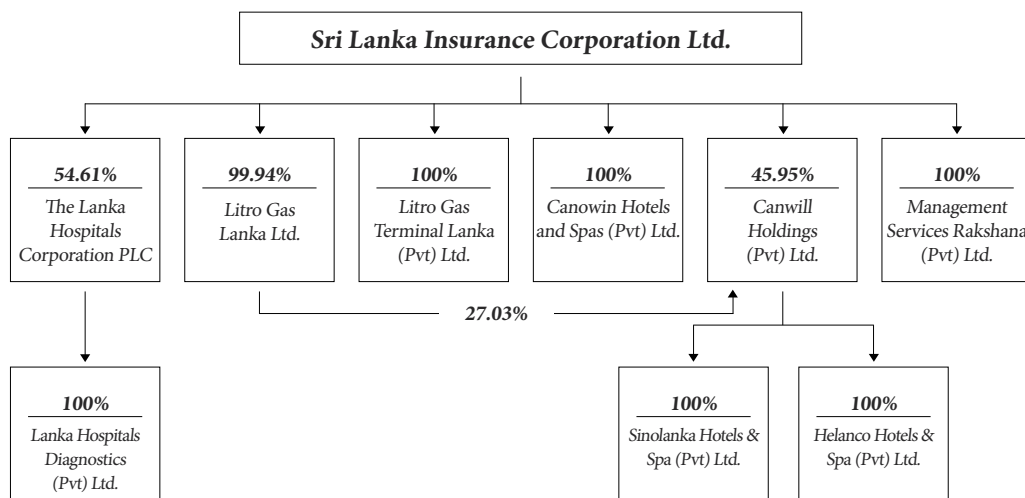

The registered office of the Company is at 'Rakshana Mandiraya', No. 21, Vauxhall Street, Colombo 02.

This Report was approved by the Board of Directors on 28th May 2015.

PRINCIPAL ACTIVITIES OF THE COMPANY AND THE GROUP

The principal activities of the Company are to transact life and non-life insurance in Sri Lanka. There were no major changes to the principal activities of the Company during the year under review.

Litro Gas Terminal Lanka (Pvt) Ltd. is involved in storage/terminalling of Liquid Petroleum Gas (LPG) and Litro Gas Lanka Ltd. provides the importation and distribution of LPG in domestic, commercial and bulk form.

The Lanka Hospitals Corporation PLC provides health care services and Management Services Rakshana (Pvt) Ltd. provides the payroll management.

Primary business of Canwill Holdings (Pvt) Ltd. is to manage/invest in hotel projects. Canowin Hotels and Spas (Pvt) Ltd. [formerly known as Sri Lanka Insurance Resorts & Spas (Pvt) Ltd.] primarily owns and manages the outlets of the Southern Express Way.

DIRECTORS' RESPONSIBILITY FOR FINANCIAL REPORTING

The Directors are responsible for preparation and presentation of Financial Statements of the Company and the Group to reflect true and fair view of its affairs. The Directors' responsibilities include designing, implementing, maintaining internal control relevant to the preparation and fair presentation of the Financial Statements that are free from material misstatements whether due to fraud or error, selecting and adopting accounting policies and making accounting estimates that are reasonable in the circumstances.

The Directors are of the view that the Statement of Financial Position, Statement of Income, Statement of Other Comprehensive Income, Statement of Changes in Equity, Cash Flow Statement, Significant Accounting Policies and Notes thereto in the Annual Report have been prepared in conformity with the Sri Lanka Financial Reporting Standards, Sri Lanka Accounting Standards, Regulation of Insurance Industry Act No. 43 of 2000 and Companies Act No. 07 of 2007.

FINANCIAL STATEMENTS AND AUDITORS' REPORT

The Financial Statements for the year ended 31st December 2014 are prepared based on the Sri Lanka Financial Reporting Standards and Sri Lanka Accounting Standards issued by The Institute of Chartered Accountants of Sri Lanka.

The Financial Statements of the Group and the Company signed by the Chief Financial Officer and the Directors are given on pages 116 to 254 in the Annual Report.

The Company's Financial Statements are audited by Messrs KPMG and the Auditors' Report issued for the financial year 2014 is given on pages 113 to 115 in this Annual Report. In accordance with the Companies Act No. 07 of 2007, a resolution relating to their reappointment and authorising the Directors to determine their remuneration will be proposed at the forthcoming Annual General Meeting.

AUDITORS' REPORT

The Financial Statements for the year ended 31st December 2014 have been audited by Messrs KPMG, a firm of Chartered Accountants and their report on Financial Statements which form an integral part of the Report of the Board of Directors is given on pages 113 to 115 in the Annual Report.

FEES ON AUDIT AND OTHER RELATED SERVICES

The amount paid as audit fees during the year under review and the amount paid as other related services are given below. The Directors are aware that the Auditors do not have any relationship interest in the Company other than those disclosed in this paragraph.

	2014 Rs. '000	2013 Rs. '000
Statutory Audit Fees	3,900	3,600
Audit Related Services	1,000	1,244
Non-Audit Related Services	12,642	3,864

ACCOUNTING POLICIES

The significant accounting policies adopted in preparation of these Financial Statements are given in the Annual Report on pages 134 to 166.

RISK AND INTERNAL CONTROL

The Board of Directors of the Company has implemented and oversees the risk management function of the Company. The policies and procedures on risk management are discussed under the risk management chapter in this report.

The Company has implemented sound internal control policies and procedures are monitored by the Internal Audit Department of the Company. The Audit and Compliance Committee oversees the Internal Control Function of the Company.

The Board is satisfied with the effectiveness of the internal control and risk management function of the Company for the year under review.

GOING CONCERN

The Board expects that the Company and the Group have adequate resources to continue its operations in foreseeable future by considering the financial positions and performance, cash flows and regulatory and statutory factors and adopts the going concern basis in preparing Financial Statements.

TURN OVER/GROSS WRITTEN PREMIUM (GWP)

The total turnover of the Company recorded Rs. 29,302 million for the year under review and Rs. 27,980 million for the comparative figure (2013).

The total GWP of Rs. 20,665 million comprised of life insurance Gross Written Premium of Rs. 8,121 million and non-life insurance Gross Written Premium of Rs. 12,545 million for the year 2014. The reported value for total Gross Written Premium in 2013 was Rs. 21,350 million out of which life insurance Gross Written Premium was Rs. 8,398 million and non-life insurance Gross Written Premium, Rs. 12,953 million for the last year. A detailed analysis of the total GWP achieved by the Company is given in the Financial Statements.

FINANCIAL RESULTS AND APPROPRIATIONS

Company	2014 Rs. million	2013 Rs. million
Profit Before Taxation (PBT)	4,373	6,354
Income Tax Expenses	1,116	1,700
Profit After Taxation	3,257	4,655
Other Comprehensive Income	(88)	5
Transfer from Life Insurance Surplus	1,690	5,461
Realisation of Revaluation Surplus	29	30
Transfer of Fair Value Gain on Investment Property	-	189
Unappropriate Profit Brought Forward	21,737	14,317
Profits Available for Appropriation	26,625	24,652
Appropriations		
Dividends Paid	1,002	1,200
Share Buyback	57	-
Transferred to Surplus from Life Insurance Business	1,612	1,721
Unappropriate Profit Carried Forward	23,954	21,737

DIVIDENDS

The Company has declared a final dividend of Rs. 3.34 per share, amounting to Rs. 2,003,142,288/-, during the year under review. The dividend of Rs. 1.67 per share amounting to Rs. 1,002,000,000/- has been declared for the year 2013. The dividends are subject to 10% withholding tax.

The Directors have confirmed that the Company satisfies the solvency test requirement under Section 56 of the Companies Act No. 07 of 2007 and has obtained a certificate from the auditors prior to declaring all dividends.

PROVISION FOR TAXATION

The tax position in the Company is disclosed in the Financial Statements on page 217.

RESERVES

The movement in reserves during the year is set out in the Statement of Changes in Equity on pages 120 to 123.

INSURANCE LIABILITIES AND PROVISIONS

The Directors have taken all reasonable steps to ensure adequate provisioning for unearned premiums and claims outstanding including provisions for Claims Incurred But Not Reported (IBNR) and Claims Incurred But Not Enough Reported (IBNER) in non-life insurance. The Directors have also consulted an independent actuary in the process of valuing IBNR and IBNER reserves and his report is given in the Annual Report.

Gratuity liability was also valued by an independent actuary as required by the LKAS 19 – 'Employee Benefits'.

As at the date of this report, the Directors are not aware of any circumstances, which would render inadequate provisions made in the Financial Statements.

INVESTMENTS

The amount of investments held by the Company as at 31st December 2014 amounted to Rs. 116,612 million (2013 – Rs. 94,772 million). A detailed breakup of the investments held is disclosed in the Financial Statements on pages 167 to 179.

PROPERTY, PLANT & EQUIPMENT

The details of property, plant and equipment are shown in the Annual Report on pages 179 to 187.

MARKET VALUE OF FREEHOLD PROPERTIES

The Company uses the cost method as the accounting policy for recording property, plant & equipment other than land and building. The Company's policy for revaluing the assets is once in every two years. Accordingly, the land and buildings were revalued in the financial year 2014 by Messrs Sunil Fernando Associates (Pvt) Ltd. Such assets were valued on an open market value for existing use basis. The results of such revaluation were incorporated in the Financial Statements from its effective date which is 31st December 2014.

EVENTS OCCURRING AFTER THE REPORTING DATE

There have not been any material events that occurred subsequent to the reporting date which require adjustments to or disclosure in the Financial Statements, other than disclosed in Notes to the Financial Statements.

RELATED PARTY TRANSACTIONS

The related party transactions as per the Sri Lanka Accounting Standards (LKAS) 24 - 'Related Party Disclosures', which is adopted in the preparation of the Financial Statements are given in this Annual Report on pages 224 to 231.

DIRECTORS' INTEREST IN CONTRACTS

The Directors' interests in contracts are disclosed in the Financial Statements. Directors do not hold any shareholding of the Company.

DIRECTORS REMUNERATIONS

The Directors' fees and emoluments paid during the year is Rs. 21.08 million and the figure reported in the last year is Rs. 27.8 million.

STATED CAPITAL

The stated capital stood at the Financial Statements is Rs. 6,000 million of the Company in compliance with the Companies Act No. 07 of 2007. As at 31st December 2014, 99.97% shares are vested with the Secretary to the Treasury on behalf of the Government of Sri Lanka.

STATUTORY PAYMENTS

The Directors, to the best of their knowledge and belief are satisfied that all statutory payments in relation to the Government, the Insurance Board of Sri Lanka (IBSL) and related to the employees have been made on time.

INTANGIBLE ASSETS

Intangible assets as at 31st December 2014 have been recorded in the Financial Statements of the Company.

ENVIRONMENT

The Company is concerned and operates with the relevant environmental laws and regulations and has not engaged in any harmful activities.

COMPLIANCE WITH LAWS AND REGULATIONS

The Company has complied with all applicable laws and regulations during the financial year. The Compliance Department monitors the compliance functions of the Company and reports to the Audit and Compliance Committee.

THE APPROVAL OF THE FINANCIAL STATEMENTS

The Audited Financial Statements were approved by the Board of Directors on 28th May 2015.

BOARD OF DIRECTORS

The following Board members ceased to be effective w.e.f. 20th January 2015:

Mr. H.K. Upali Dharmadasa

Mr. P. Kudabalage

Mr. H. Isuru Balapatabendi

Mr. S.V.R. Samarasinghe

Mr. Nayana D.P. Dehigama

Ms. K.M.A. Nelumani Daulagala

The following members were appointed w.e.f. 20th January 2015:

Prof. L.G. Chandrasena

Mr. H. Imal S. Fonseka

Mr. P. Algama

The following members were appointed w.e.f. 09th February 2015:

Mr. Hemaka D.S. Amarasuriya

Mr. T.M.R. Bangsa Jayah

Mr. P.P.J. Perera

ANNUAL GENERAL MEETING

The Annual General Meeting will be held on 30th June 2015 at the Auditorium of the Company at its registered office at No. 21, Vauxhall Street, Colombo 02 at 10.00 a.m.

By Order of the Board,



Varners International (Pvt) Ltd.

Company Secretaries

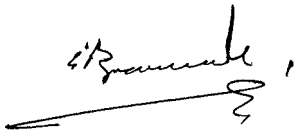

T.M.R. Bangsa Jayah

Managing Director



P.P.J. Perera

Executive Director

1st June 2015

7.2.0 STATEMENT OF DIRECTORS' RESPONSIBILITY

The responsibility of the Directors, in relation to the Financial Statements, is set out in the following statement. The responsibility of the Auditors, in relation to the Financial Statements, is set out in the Report of the Auditors on pages 113 to 115 of the Annual Report.

Directors are of the view that the Financial Statements have been prepared under the generally accepted accounting principles and in conformity with the requirements of SLFRSs/ LKASs, the Companies Act No. 07 of 2007 and the Regulation of Insurance Industry Act No. 43 of 2000.

The Directors confirm that appropriate accounting policies have been consistently applied and supported by prudent judgments and estimates in the preparation of Financial Statements. Further, the Directors ensure that the Company has adequate resources to continue in operation to justify applying the going concern basis in preparing these Financial Statements. In addition, the Directors have confirmed that the Company maintains sufficient accounting records to disclose, with reasonable accuracy of the financial position of the Company.

Further, the Directors have taken all reasonable steps to ensure adequate provisioning for Unearned Premium, Unexpired Risks, Outstanding Claims including Claims Incurred But Not Reported, Incurred But Not Enough Reported and Receivables.

Directors confirm that to the best of their knowledge all taxes, duties and levies payable by the Company and all contributions and taxes payable on behalf of employees of the Company and all other known statutory dues, as at the reporting date have been paid or provided for.

The Directors adopted a report from the actuary on which bonus payable to policyholders and the surplus available to shareholders in Life Insurance business were determined.

By Order of the Board,



Varners International (Pvt) Ltd.

Company Secretaries

1st June 2015

7.3.0 CHIEF EXECUTIVE OFFICER’S AND CHIEF FINANCIAL OFFICER’S RESPONSIBILITY STATEMENT

The Financial Statements of Sri Lanka Insurance Corporation Ltd. (the Company) and the Consolidated Financial Statements of the Company and its Subsidiaries (the Group) as at 31st December 2014 are prepared and presented in conformity with the requirements stipulated in Sri Lanka Accounting Standards issued by The Institute of Chartered Accountants of Sri Lanka, Companies Act No. 07 of 2007 and the Regulation of Insurance Industry Act No. 43 of 2000. The formats used in the preparation of the Financial Statements and disclosures made therein comply with the formats prescribed by the relevant regulators.

We confirm that to the best of our knowledge the Financial Statements, significant accounting policies and other financial information included in this Annual Report fairly represent in all material respects the financial condition, results of the operations and the cash flow of the Company during the year under review. In addition, we confirm that the Company has adequate resources to continue its operations and has applied the going concern basis in preparing these Financial Statements.

The Board of Directors is responsible for ensuring that management fulfills its financial reporting responsibilities. As the Company’s Chief Executive Officer and Chief Financial Officer we are responsible for having established and maintaining disclosure controls and procedures and internal controls over financial reporting. Management has a system of internal controls designed to provide reasonable assurance that the Financial Statements are accurate and complete in all material respects. Management believes that the internal controls provide reasonable assurance that the financial records are reliable and form a proper basis for preparing the Financial Statements, and that the assets are properly accounted for and safeguarded.

The Board of Directors has appointed an Audit and Compliance Committee, which is headed by an Independent Director. The Audit and Compliance Committee’s responsibilities include reviewing the Financial Statements and recommending those to the Board of Directors for approval.

The Financial Statements have been audited, on behalf of the shareholders, by Messrs KPMG, the Independent Auditor, in accordance with the applicable laws, rules and regulations and applicable accounting standards. The Independent Auditor has full and free access to the Audit and Compliance Committee and may meet with or without the presence of the management.

We confirm to the best of our knowledge that –

- i. the Company has complied with all applicable laws, rules and regulations and guidelines as otherwise expressed in the Notes to the Financial Statements;
- ii. there are no material non-compliances as otherwise expressed in the Notes to the Financial Statements;
- iii. all taxes, duties and all statutory payments by the Company and all contributions and taxes payable on behalf of and in respect of the employees of the Company as at the reporting date have been paid, or where relevant provided for;
- iv. reserving and solvency guidelines have been complied with and total reserves are backed by matching admissible assets; and
- v. the equity capital meets the set minimum capital requirements in accordance with the applicable regulations.

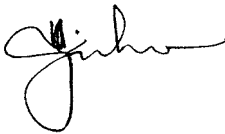

Ranjith Perera

Senior Deputy General Manager - Finance/Chief Financial Officer



Deepthi Lokuarachchi

Chief Executive Officer

1st June 2015

7.4.0 CERTIFICATE OF ACTUARY OF THE INSURER

TOWERS WATSON 

63 Chulia Street
#09-01 OCBC Centre East
Singapore 049514
T +65 6880 5688
F +65 6880 5699
towerswatson.com

- I. Mark Alan Birch, being the Actuary for the life insurance business, to the best of my knowledge certify the following:
- a. that I have included each and every policy for which there is a policy liability in conducting the valuation of liabilities for the purpose of Section 48 of the Regulation of Insurance Industry Act No. 43 of 2000, and the Solvency Margin Rules;
 - b. that I have taken all reasonable steps to ensure the accuracy and completeness of the policies mentioned in item (a) above;
 - c. that I have complied with the provisions of the said act in item (a) above;
 - d. that I have complied with provisions of the Solvency Margin (Long Term Insurance) Rules, 2002 and guidance notes/guidelines prescribed by the Board thereunder in the determination of the net amount of liabilities;
 - e. that in my opinion the net liability so determined by me, in the form H-LT - the valuation balance sheet, is adequate to meet the insurer's future commitments under the insurance contracts, and the policyholders' reasonable expectations.

Name and address of actuary with phone number and e-mail:

Mark Alan Birch, FIA

Director, Risk Consulting and Software, South East Asia

Towers Watson Singapore Pte Ltd.

63, Chulia Street # 09-01

OCBC Centre East

Singapore 049514

Telephone: (65) 6880-5688

Fax: (65) 6880-5699

E-mail: mark.birch@towerswatson.com

Signature:



Place: Singapore

Date: 10th April 2015

Towers Watson Singapore Pte Ltd
Company Registration No: 198600361K

7.5.0 LIABILITY ADEQUACY TEST

TOWERS WATSON 

63 Chulia Street
#09-01 OCBC Centre East
Singapore 049514
T +65 6880 5688
F +65 6880 5699
towerswatson.com

- 1.1 The Sri Lanka Accounting Standard 'SLFRS 4, Insurance Contracts' prescribes that an insurer shall assess at the end of each Reporting period whether its recognised insurance liabilities are adequate, using current estimates of future cash flows under its insurance contracts. Towers Watson has undertaken a liability adequacy test for long-term insurance provisions maintained within the life fund of Sri Lanka Insurance Corporation Ltd. as contemplated by SLFRS 4.
- 1.2 In carrying out the liability adequacy test, we have compared the provisions held as per the audited accounts with the actuarial liability. For this purpose, the value of the actuarial liability is computed following the principles laid out within the risk-based capital framework as prescribed by the IBSL, whereby liabilities are valued using a discounted cash flow approach covering the full lifetime of all the cash in and out flows required to settle the obligations related to existing in force insurance contracts.
- 1.3 The projections are based on in force policies and riders as at 31st December 2014.
- 1.4 Based on the checks undertaken, I certify–
 - that the valuation of actuarial liability is based on internationally accepted actuarial methods and adheres to the requirements under SLFRS 4;
 - that the assumptions used for such valuation are reasonable estimates based on available experience studies and after allowing for suitable margins for adverse deviation; and
 - that the long term insurance provisions maintained within the life fund of Sri Lanka Insurance Corporation Ltd., as per the audited accounts of the Company for the year ended 31st December 2014 is in excess of the liabilities computed in the above-mentioned manner.

Mark Alan Birch, FIA

Director, Risk Consulting and Software, South East Asia
Towers Watson Singapore Pte Ltd.

Signature: 

Place: Singapore

Date: 10th April 2015

Towers Watson Singapore Pte Ltd
Company Registration No: 198600361K

7.6.0 CERTIFICATION OF INCURRED BUT NOT (ENOUGH) REPORTED CLAIMS



I hereby certify that the 75% confidence level IBNR provision, including an allowance of CHE, of Rs. 2,182,472,000/- is adequate in relation to the Claim Liability of Sri Lanka Insurance Corporation Ltd. as at 31st December 2014, net of reinsurance (undiscounted). This IBNR provision, together with the Case Reserves held by the Company, is expected to be adequate to meet the future liabilities in respect of the Company's incurred claims obligations as at 31st December 2014, in many but not all scenarios of future experience.

At the end of each reporting period, companies are required to carry out a Liability Adequacy Test (LAT) as laid out in SLFRS 4. The LAT is performed to assess the adequacy of the carrying amount of the Unearned Premium Reserve (UPR). I hereby certify that the UPR provision of Rs. 5,235,223,000/- set by the Company, net of reinsurance, is adequate in relation to the unexpired risks of Sri Lanka Insurance Corporation Ltd. as at 31st December 2014, in many but not all scenarios of future experience. As such, there is no premium deficiency to be recognised by the Company.

The results have been determined in accordance with internationally accepted actuarial principles.

I have relied upon information and data provided by the management of the above Company and I have not independently verified the data supplied, beyond applying checks to satisfy myself as to the reasonableness of the data.

A handwritten signature in black ink, appearing to read 'Matthew Maguire'.

Matthew Maguire

Fellow of the Institute of Actuaries of Australia (FIAA)

For and on behalf of NMG Financial Services Consulting

Dated 7th April 2015

7.7.0 INDEPENDENT AUDITORS’ REPORT



KPMG
 (Chartered Accountants)
 32A, Sir Mohamed Macan Markar Mawatha,
 P. O. Box 186,
 Colombo 00300,
 Sri Lanka.

Tel : +94 - 11 542 6426
 Fax : +94 - 11 244 5872
 +94 - 11 244 6058
 +94 - 11 254 1249
 +94 - 11 230 7345
 Internet : www.lk.kpmg.com

TO THE SHAREHOLDERS OF SRI LANKA INSURANCE CORPORATION LIMITED REPORT ON THE FINANCIAL STATEMENTS

We have audited the accompanying Financial Statements of Sri Lanka Insurance Corporation Ltd., (‘the Company’), and the Consolidated Financial Statements of the Company and its Subsidiaries (‘Group’), which comprise the Statement of Financial Position as at 31st December 2014, and the statement of profit or loss and other comprehensive income, statement of changes in equity and, cash flow statement for the year then ended, and a summary of significant accounting policies and other explanatory information as set out in pages 134 to 254.

BOARD’S RESPONSIBILITY FOR THE FINANCIAL STATEMENTS

The Board of Directors (‘Board’) is responsible for the preparation of these Financial Statements that give a true and fair view in accordance with Sri Lanka Accounting Standards, and for such internal control as Board determines is necessary to enable the preparation of Financial Statements that are free from material misstatement, whether due to fraud or error.

AUDITORS’ RESPONSIBILITY

Our responsibility is to express an opinion on these Financial Statements based on our audit. We conducted our audit in accordance with Sri Lanka Auditing Standards. Those standards require that we comply with ethical requirements and plan and perform the audit to obtain reasonable assurance about whether the Financial Statements are free from material misstatement.

An audit involves performing procedures to obtain audit evidence about the amounts and disclosures in the Financial Statements. The procedures selected depend on the Auditor’s judgment, including the assessment of the risks of material misstatement of the Financial Statements, whether due to fraud or error. In making those risk assessments, the auditor considers

internal control relevant to the entity's preparation of the Financial Statements that give a true and fair view in order to design audit procedures that are appropriate in the circumstances, but not for the purpose of expressing an opinion on the effectiveness of the entity's internal control. An audit also includes evaluating the appropriateness of accounting policies used and the reasonableness of accounting estimates made by Board, as well as evaluating the overall presentation of the Financial Statements.

We believe that the audit evidence we have obtained is sufficient and appropriate to provide a basis for our audit opinion.

OPINION

1. According to the judgment delivered by Supreme Court of Sri Lanka on 4th June 2009, the legal ownership of the majority of the shares of the Company was vested with the Secretary to the Treasury to be held on behalf of the Government of Sri Lanka. Further, according to the said judgment, the Secretary to the Treasury was directed to cause profits of the Company during the period Distilleries Company of Sri Lanka PLC was the Parent of the Company, be computed and the profits attributable to the previous Parent be settled. No adjustments have been made in the Financial Statements pending determination of the aforesaid attributable profits.
2. In the absence of confirmation of balances, we were unable to satisfy ourselves as to the completeness, existence and accuracy of amount due from the Distilleries Company of Sri Lanka PLC Group of Companies as disclosed in Note 15 to the Financial Statements.

In our opinion, except for the effect of such adjustments, if any, as might have been determined to be necessary had we been able to satisfy ourselves as to the matters disclosed in the aforesaid paragraphs 1 and 2, the Consolidated Financial Statements give a true and fair view of the financial position of the Group as at 31st December 2014, and of its financial performance and cash flows for the year then ended in accordance with Sri Lanka Accounting Standards.

REPORT ON OTHER LEGAL AND REGULATORY REQUIREMENTS

As required by Section 163 (2) of the Companies Act No. 07 of 2007, we state the following:

- (a) The basis of opinion and scope and limitations of the audit are as stated above.
- (b) In our opinion; we have obtained all the information and explanations that were required for the audit.

1. According to the judgment delivered by Supreme Court of Sri Lanka on 04th June 2009, the legal ownership of the majority of the shares of the Company was vested with the Secretary to the Treasury to be held on behalf of the Government of Sri Lanka. Further, according to the said judgment, the Secretary to the Treasury was directed to cause profits of the Company during the period Distilleries Company of Sri Lanka PLC was the Parent of the Company, be computed and the profits attributable to the previous Parent be settled. No adjustments have been made in the Financial Statements pending determination of the aforesaid attributable profits.
2. In the absence of confirmation of balances, we were unable to satisfy ourselves as the completeness, existence and accuracy of amount due from the Distilleries Company of Sri Lanka PLC Group of Companies disclosed in Note 15 to the Financial Statements.

In our opinion; except for the effect of such adjustments, as might have been determined to be necessary had we been able to satisfy ourselves as to the matters disclosed in the aforesaid paragraphs 1 and 2 above.

- As far as appears from our examination, proper accounting records have been kept by the Company.
- The Financial Statements of the Company, give a true and fair view of its financial position as at 31st December 2014, and of its financial performance and cash flows for the year then ended in accordance with Sri Lanka Accounting Standards.

In our opinion; the Financial Statements of the Company, and the Group comply with the requirements of Sections 151 and 153 of the Companies Act No. 07 of 2007.

As required by Section 47 (2) of the Regulation of Insurance Industry Act No. 43 of 2000, the accounting records of the Company have been maintained in the manner required by the rules issued by the IBSL and give a true and fair view of the financial position.



Chartered Accountants
Colombo

01st June 2015

KPMG, a Sri Lankan partnership and a member firm of the KPMG network of independent member firms affiliated with KPMG International Cooperative ("KPMG International"), a Swiss entity.

M.R. Mihular FCA	P.Y.S. Perera FCA	C.P. Jayatilake FCA
T.J.S. Rajakarier FCA	W.W.J.C. Perera FCA	Ms. S. Joseph FCA
Ms. S.M.B. Jayasekara ACA	W.K.D.C. Abeyratne ACA	S.T.D.L. Perera FCA
G.A.U. Karunaratne ACA	R.M.D.B. Rajapakse ACA	Ms. B.K.D.T.N. Rodrigo ACA
R.H. Rajan ACA		

Principals - S.R.I. Perera FCMA(UK), LLB, Attorney-at-Law, H.S. Goonewardene ACA

7.8.0 STATEMENT OF FINANCIAL POSITION

As at 31st December	Note	Consolidated		Company	
		2014 Rs. '000	2013 Rs. '000	2014 Rs. '000	2013 Rs. '000
Assets					
Financial Investments	5	116,624,612	94,771,272	116,624,612	94,771,272
Investment in Subsidiaries	6	-	-	21,085,905	17,585,904
Property, Plant & Equipment	7	35,583,199	30,812,895	8,585,240	8,265,863
Investment Properties	8	1,203,431	1,333,645	465,231	549,600
Leasehold Property	9	357,003	190,473	20,806	21,075
Intangible Assets	10	3,166,771	3,119,603	141,336	120,041
Loans to Policyholders	11	1,510,067	1,578,196	1,510,067	1,578,196
Reinsurance Receivable	12	1,206,845	1,446,243	1,206,845	1,446,243
Premium Receivable	13	2,858,302	3,030,141	2,858,302	3,030,141
Deferred Tax Assets	14	87,013	56,876	86,629	56,469
Other Assets	15	6,684,373	6,378,029	3,577,108	2,860,377
Deferred Expenses	16	261,860	246,895	261,860	246,895
Cash and Cash Equivalents	17	25,539,438	29,257,992	5,768,427	13,024,534
Total Assets		195,082,914	172,222,260	162,192,368	143,556,610
Liabilities and Shareholders' Equity					
Equity					
Stated Capital	18	6,000,000	6,000,000	6,000,000	6,000,000
Revaluation Reserve	19	9,325,393	8,752,045	5,971,570	5,411,866
Available-For-Sale Reserve	20	26,525,252	15,364,711	26,525,252	15,364,711
Revenue Reserve	21	37,499,812	33,278,963	25,719,488	26,398,587
Total Equity Attributable to Equity					
Holders of the Company		79,350,457	63,395,719	64,216,310	53,175,164
Non-Controlling Interest		7,246,077	7,054,574	-	-
Total Equity		86,596,534	70,450,293	64,216,310	53,175,164

As at 31st December	Note	Consolidated		Company	
		2014 Rs. '000	2013 Rs. '000	2014 Rs. '000	2013 Rs. '000
Liabilities					
Insurance Provision – Life	22	77,254,496	69,079,061	77,254,496	69,079,061
Insurance Provision – Non-Life	23	13,195,783	13,288,956	13,195,783	13,288,956
Reinsurance Payable		1,013,511	897,082	1,013,511	897,082
Current Tax Liabilities	24	1,472,546	2,778,544	963,165	1,739,675
Deferred Tax Liabilities	25	2,834,628	2,808,369	743,056	935,656
Retirement Benefit Obligations	26	872,575	635,244	668,381	463,117
Other Liabilities	27	11,243,513	11,787,935	3,748,759	3,616,178
Bank Overdraft	28	599,328	496,776	388,907	361,721
Total Liabilities		108,486,380	101,771,967	97,976,058	90,381,446
Total Liabilities and Equity		195,082,914	172,222,260	162,192,368	143,556,610

Notes to the Financial Statements as set out on pages 134 to 254 form an integral part of these Financial Statements.

I certify that the above Financial Statements comply with the requirements of the Companies Act No. 07 of 2007.

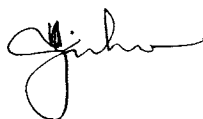

Ranjith Perera

Chief Financial Officer/Senior DGM Finance

The Board of Directors are responsible for the preparation and the presentation of these Financial Statements.

Approved and signed for and on behalf of the Board,



Hemaka Amarasuriya

Chairman

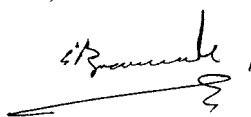

T.M.R. Bangsa Jayah

Managing Director

Colombo

1st June 2015

7.9.0 STATEMENTS OF PROFIT OR LOSS AND OTHER COMPREHENSIVE INCOME

For the year ended 31st December	Note	Consolidated		Company	
		2014 Rs. '000	2013 Rs. '000	2014 Rs. '000	2013 Rs. '000
Revenue	29	64,223,649	60,074,704	29,301,980	27,980,852
Gross Written Premium	30	20,584,486	21,262,140	20,665,985	21,350,869
Net Change in Reserve for Unearned Premium		(125,047)	(581,750)	(125,047)	(581,750)
Gross Earned Premium		20,459,439	20,680,390	20,540,938	20,769,119
Premium Ceded to Reinsurers		(2,845,418)	(3,227,303)	(2,845,418)	(3,227,303)
Net Change in Reserve for Unearned Reinsurance Premium		109,385	263,241	109,385	263,241
Net Earned Premium		17,723,406	17,716,327	17,804,905	17,805,056
Revenue from Subsidiaries		33,716,092	32,139,598	-	-
		51,439,498	49,855,925	17,804,905	17,805,056
Other Revenue					
Investment Income	31	11,708,619	8,895,213	11,216,572	9,275,563
Fees and Commission Income	32	49,296	27,881	49,296	27,881
Net Realised Gains/(Losses)	33	(152,291)	39,906	(157,737)	39,906
Net Fair Value Gains and Losses		-	(12,671)	-	(12,671)
Other Income	34	1,178,527	1,268,450	388,944	845,117
		12,784,151	10,218,779	11,497,075	10,175,797
Total Net Revenue		64,223,649	60,074,704	29,301,980	27,980,853
Benefits, Losses and Expenses					
Net Benefits and Claims	35	(11,939,320)	(9,804,484)	(11,939,320)	(9,804,484)
Underwriting and Net Acquisition Costs (Including Reinsurance)	36	(1,613,242)	(1,553,928)	(1,613,242)	(1,553,928)
Change in Contract Liabilities - Life Fund		(5,376,416)	(5,109,549)	(5,376,416)	(5,109,549)
Other Operating and Administrative Expenses	37	(9,596,478)	(6,542,048)	(5,999,863)	(5,158,022)
Cost of Sales of Subsidiaries		(24,545,071)	(23,267,517)	-	-
Net Benefits, Losses and Expenses		(53,070,527)	(46,277,526)	(24,928,841)	(21,625,983)
Profit Before Taxation		11,153,122	13,797,179	4,373,139	6,354,870
Income Tax Expense	38	(2,813,454)	(3,658,388)	(1,116,126)	(1,700,039)
Net Profit for the Year		8,339,668	10,138,790	3,257,013	4,654,830

For the year ended 31st December	Note	Consolidated		Company	
		2014 Rs. '000	2013 Rs. '000	2014 Rs. '000	2013 Rs. '000
Other Comprehensive Income					
Gain on Revaluation of Property, Plant & Equipment		669,662	212,925	592,783	-
Deferred Tax Effect on Revaluation of Property, Plant & Equipment		(3,683)	(25,551)	(3,778)	-
Net Change in Fair Value of Available-For-Sale Financial Assets		11,160,541	2,843,670	11,160,541	2,843,670
Actuarial Gains/(Losses) on Retirement Benefit Obligations		(127,024)	8,554	(122,160)	5,992
Tax on Actuarial Gains/(Losses)		35,313	(1,259)	34,205	-
Other Comprehensive Income for the Year, Net of Tax		11,734,809	3,038,339	11,661,591	2,849,662
Total Comprehensive Income for the Year		20,074,477	13,177,129	14,918,604	7,504,492
Profit for the Year Attributable to:					
Equity Holders of the Company		8,037,407	9,681,178	3,257,013	4,654,830
Non-Controlling Interest		302,261	457,613	-	-
Profit for the Year		8,339,668	10,138,790	3,257,013	4,654,830
Total Comprehensive Income Attributable to:					
Equity Holders of the Company		19,754,844	12,635,592	14,918,604	7,504,492
Non-Controlling Interest		319,633	541,537	-	-
Total Comprehensive Income for the Year		20,074,477	13,177,129	14,918,604	7,504,492
Basic Earnings Per Share (Rs.)	39	13.40	16.14	5.43	7.76

The above Statement of Profit or Loss and Other Comprehensive Income is to be read in conjunction with the Notes to the Financial Statements, from pages 134 to 254 which form an integral part of these Financial Statements.

7.10.0 STATEMENT OF CHANGES IN EQUITY**Consolidated**

	Stated Capital Rs. '000	Revaluation Reserve Rs. '000
Balance as at 1st January 2013	6,000,000	9,161,368
Total Comprehensive Income for the Year		
Profit for the year	-	-
Other comprehensive income	-	102,325
Total Comprehensive Income for the Year	-	102,325
Transaction with Owners of the Company Recorded Directly in Equity		
Effect of Change in Percentage Holding in Subsidiaries	-	-
Deferred Tax on Revaluation Surplus	-	(291,353)
Realisation of Revaluation Surplus	-	(30,320)
Transfer of Fair Value Gain on Investment Property	-	(189,975)
Change in Fair Value measurements applicable to Life Contract liability	-	-
Transferred from Life Insurance Surplus	-	-
Surplus attributable to shareholders of Life Insurance	-	-
Dividend Paid by Subsidiary Companies to Minority Interest	-	-
Dividend Paid	-	-
	-	(511,648)
Balance as at 31st December 2013	6,000,000	8,752,045
Total Comprehensive Income for the Year		
Profit for the Year	-	-
Other Comprehensive Income	-	644,950
Total Comprehensive Income for the Year	-	644,950
Transaction with Owners of the Company Recorded Directly in Equity		
Effect of Change in Percentage Holding in Subsidiaries	-	-
Realisation of Revaluation Surplus	-	(71,602)
Share Buyback	-	-
Transfer to Shareholders	-	-
Change in Fair Value Measurements Applicable to Life Contract Liability	-	-
Surplus Attributable to Shareholders of Life Insurance	-	-
Dividend Paid	-	-
Dividends of Subsidiaries to Non-Controlling Interest	-	-
	-	(71,602)
Balance as at 31st December 2014	6,000,000	9,325,393

The above Statement of Changes in Equity is to be read in conjunction with the Notes to the Financial Statements, from pages 134 to 254 which form an integral part of these Financial Statements.

General Reserve Rs. '000	Available-For-Sale Reserve Rs. '000	Attributable to Owners of the Company			Non-Controlling Interest Rs. '000	Total Equity Rs. '000
		Surplus from Life Insurance Rs. '000	Retained Earnings Rs. '000	Total Rs. '000		
643,442	12,521,041	8,268,740	16,753,420	53,348,011	1,647,283	54,995,294
-	-	-	9,681,178	9,681,178	457,613	10,138,791
-	2,843,670	-	8,420	2,954,415	83,924	3,038,339
-	2,843,670	-	9,689,598	12,635,593	541,538	13,177,130
-	-	-	(68,857)	(68,857)	5,068,857	5,000,000
-	-	-	289,484	(1,869)	-	(1,869)
-	-	-	30,320	-	-	-
-	-	-	189,975	-	-	-
-	-	-	(1,317,160)	(1,317,160)	-	(1,317,160)
-	-	(5,461,681)	5,461,681	-	-	-
-	-	1,721,809	(1,721,809)	-	-	-
-	-	-	-	-	(203,104)	(203,104)
-	-	-	(1,200,000)	(1,200,000)	-	(1,200,000)
-	-	(3,739,872)	1,663,635	(2,587,886)	4,865,753	2,277,867
643,442	15,364,711	4,528,867	28,106,652	63,395,718	7,054,574	70,450,293
-	-	-	8,037,407	8,037,407	302,261	8,339,668
-	11,160,541	-	(88,055)	11,717,436	17,373	11,734,809
-	11,160,541	-	7,949,352	19,754,843	319,634	20,074,477
-	-	-	77,355	77,355	(77,355)	-
-	-	-	71,602	-	-	-
-	-	-	(57,245)	(57,245)	-	(57,245)
-	-	(1,690,604)	1,690,604	-	-	-
-	-	-	(2,818,040)	(2,818,040)	-	(2,818,040)
-	-	1,612,402	(1,612,402)	-	-	-
-	-	-	(1,002,000)	(1,002,000)	-	(1,002,000)
-	-	-	-	-	(50,776)	(50,776)
-	-	(78,202)	(3,650,299)	(3,800,103)	(128,131)	(3,928,234)
643,442	26,525,252	4,450,665	32,405,705	79,350,458	7,246,077	86,596,534

Company

	Stated Capital Rs. '000	Revaluation Reserve Rs. '000
Balance as at 1st January 2013	6,000,000	5,632,161
Total Comprehensive Income for the Year		
Profit for the Year	-	-
Other Comprehensive Income	-	-
Total Comprehensive Income for the Year	-	-
Transaction with Owners of the Company Recorded Directly in Equity		
Transfer from Life Insurance Surplus	-	-
Change in Fair Value Measurements Applicable to Life Contract Liability	-	-
Realisation of Revaluation Surplus	-	(30,320)
Amount Transfer on Investment Property	-	(189,975)
Surplus attributable to Shareholders of Life Insurance	-	-
Dividend Declared and Paid	-	-
Balance as at 31st December 2013	6,000,000	5,411,866
Balance as at 1st January 2014	6,000,000	5,411,866
Total Comprehensive Income for the Year		
Profit for the Year	-	-
Other Comprehensive Income	-	589,005
Total Comprehensive Income for the Year	6,000,000	6,000,871
Transaction With owners of the Company Recorded Directly in Equity		
Transferred from Life Insurance Surplus	-	-
Change in fair Value Measurements Applicable to Life Contract Liability	-	-
Realisation of Revaluation Surplus	-	(29,301)
Share Buyback	-	-
Surplus Attributable to Shareholders from Life Insurance	-	-
Dividend Declared and Paid	-	-
Balance as at 31st December 2014	6,000,000	5,971,570

Dividend Per Share (Rs.)

The above Statement of Changes in Equity is to be read in conjunction with the Notes to the Financial Statements, from pages 134 to 254 which form an integral part of these Financial Statements.

Available-For-Sale Reserve Rs. '000	General Reserve Rs. '000	Surplus from Life Insurance Rs. '000	Retained Earnings Rs. '000	Total Equity Rs. '000
12,521,041	643,442	8,268,739	15,122,448	48,187,831
-	-	-	4,654,830	4,654,830
2,843,670	-	-	5,992	2,849,662
2,843,670	-	-	4,660,824	7,504,492
-	-	(5,461,681)	5,461,681	-
-	-	-	(1,317,160)	(1,317,160)
-	-	-	30,320	-
-	-	-	189,975	-
-	-	1,721,809	(1,721,809)	-
-	-	-	(1,200,000)	(1,200,000)
15,364,711	643,442	4,528,867	21,226,278	53,175,163
15,364,711	643,442	4,528,867	21,226,278	53,175,163
-	-	-	3,257,013	3,257,013
11,160,541	-	-	(87,955)	11,661,591
26,525,252	643,442	4,528,867	24,395,336	68,093,768
-	-	(1,690,604)	1,690,604	-
-	-	-	(2,818,040)	(2,818,040)
-	-	-	29,301	-
-	-	-	(57,245)	(57,245)
-	-	1,612,402	(1,612,402)	-
-	-	-	(1,002,000)	(1,002,000)
26,525,252	643,442	4,450,665	20,625,381	64,216,310
		Note	2014	2013
		40	3.34	1.67

7.11.0 STATEMENTS OF CASH FLOWS

For the Year ended 31st December	Note	Consolidated		Company	
		2014 Rs. '000	2013 Rs. '000	2014 Rs. '000	2013 Rs. '000
Cash Flows From Operating Activities					
Premium Received from Customers		20,955,020	20,648,417	20,955,020	20,648,417
Reinsurance Premium Paid		(2,365,481)	(3,091,309)	(2,365,481)	(3,091,309)
Insurance Claims and Benefits Paid		(12,347,406)	(11,121,142)	(12,347,406)	(11,121,142)
Reinsurance Receipts in Respect of Claims and Benefits		519,628	494,544	519,628	494,544
Cash Receipts from Debtors		32,219,245	31,163,171	-	-
Cash Paid to and on behalf of Employees		(3,988,233)	(1,761,484)	(2,280,087)	(1,761,484)
Interest Received		8,750,100	8,527,290	7,716,553	6,879,751
Dividend Received		1,337,454	1,435,954	1,646,243	1,816,390
Other Operating Cash Payments		(26,031,418)	(26,271,054)	(5,964,686)	(4,990,794)
Cash Flow from Operating Activities		19,048,909	20,024,387	7,879,785	8,874,373
Retiring Gratuity Paid		(26,914)	(12,873)	-	-
Income Tax Paid		(4,208,954)	(2,275,409)	(2,084,970)	(1,093,030)
Net Cash Flow From Operating Activities		14,813,041	17,736,105	5,794,816	7,781,343
Cash Flow From Investing Activities					
Acquisition of Financial Investments		(62,612,872)	(62,297,361)	(59,112,871)	(61,427,775)
Investments in Subsidiaries		-	-	(3,500,001)	(869,586)
Proceeds from Financial Investments		50,685,905	60,422,919	50,685,905	60,422,919
Proceeds from Disposal of Property, Plant & Equipment		109,234	34,893	68,758	30,320
Acquisition of Property, Plant & Equipment		(5,662,124)	(7,513,898)	(217,458)	(196,144)
Net Cash Flows Used in Investing Activities		(17,479,857)	(9,353,447)	(12,075,667)	(2,040,267)

For the Year ended 31st December	Note	Consolidated		Company	
		2014 Rs. '000	2013 Rs. '000	2014 Rs. '000	2013 Rs. '000
Cash Flow from Financing Activities					
Dividend Paid		(1,002,000)	(1,200,000)	(1,002,000)	(1,200,000)
Net Flows Used in Financing Activities		(1,002,000)	(1,200,000)	(1,002,000)	(1,200,000)
Effect of Exchange Rate Changes on Cash and Cash Equivalents		(152,291)	37,996	442	55,379
Net Increase/(Decrease) in Cash and Cash Equivalents		(3,821,106)	7,220,654	(7,283,293)	4,596,455
Cash and Cash Equivalents at the Beginning of the Year		28,761,216	21,540,562	12,662,813	8,066,358
Cash and Cash Equivalents at the end of the Year		24,940,110	28,761,216	5,379,520	12,662,813
Cash and Cash Equivalents at the end of the Year					
Cash at Bank and in Hand	17	901,895	767,825	637,799	493,965
Short-Term Investments	17	24,637,543	28,490,167	5,130,628	12,530,569
Bank Overdraft	28	(599,328)	(496,776)	(388,907)	(361,721)
		24,940,110	28,761,216	5,379,520	12,662,813

The above Statement of Cash Flows is to be read in conjunction with the Notes to the Financial Statements, from pages 134 to 254 which form an integral part of these Financial Statements.

7.12.0 SEGMENTAL REVIEW: STATEMENT OF INCOME

	2014						
	Non-Life Insurance	Life Insurance	Healthcare	Energy	Other	Eliminations	Total
	Rs. '000	Rs. '000	Rs. '000	Rs. '000	Rs. '000	Rs. '000	Rs. '000
Gross Written Premium	12,544,828	8,121,159	-	-	-	(81,499)	20,584,488
Net Change in Reserves for Unearned Premium	(2,709,017)	(136,401)	-	-	-	-	(2,845,418)
Gross Earned Premium	9,835,811	7,984,758	-	-	-	(81,499)	17,739,070
Premium Ceded to Reinsurers	-	-	-	-	-	-	-
Net Change in Reserve for Unearned Reinsurance Premium	(15,661)	-	-	-	-	-	(15,661)
Net Earned Premium	9,820,149	7,984,758	-	-	-	(81,499)	17,723,408
Revenue from Other Operations	-	-	4,753,589	30,078,576	24,960	-	34,857,125
Total Revenue	9,820,149	7,984,758	4,753,589	30,078,576	24,960	(81,499)	52,580,533
Benefits and Losses							
Insurance Claims and Benefits (Net)	(6,205,796)	(5,733,524)	-	-	-	-	(11,939,321)
Underwriting and Net Acquisition Costs	(485,323)	(1,127,919)	-	-	-	-	(1,613,242)
Other Insurance-Related Costs	-	-	-	-	-	-	-
Increase in Life Insurance Fund	-	(5,376,416)	-	-	-	-	(5,376,416)
Cost of Services of Subsidiaries	-	-	(2,058,866)	(23,627,238)	-	-	(25,686,104)
Total Benefits and Losses	(6,691,119)	(12,237,860)	(2,058,866)	(23,627,238)	-	-	(44,615,083)

2013						
Non-Life Insurance Rs. '000	Life Insurance Rs. '000	Healthcare Rs. '000	Energy Rs. '000	Other Rs. '000	Eliminations Rs. '000	Total Rs. '000
12,953,151	8,397,718	-	-	-	(88,729)	21,262,140
(581,750)	-	-	-	-	-	(581,750)
12,371,400	8,397,718	-	-	-	(88,729)	20,680,390
(3,129,667)	(97,636)	-	-	-	-	(3,227,303)
263,241	-	-	-	-	-	263,241
9,504,974	8,300,082	-	-	-	(88,729)	17,716,327
-	-	4,071,915	29,038,945	79,155	(1,050,418)	32,139,598
9,504,974	8,300,082	4,071,915	29,038,945	79,155	(1,139,146)	49,855,925
(4,934,074)	(4,870,410)	-	-	-	-	(9,804,484)
(500,629)	(1,053,299)	-	-	-	-	(1,553,928)
-	-	-	-	-	-	-
-	(5,109,549)	-	-	-	-	(5,109,549)
-	-	(1,691,624)	(22,481,096)	(27,410)	932,613	(23,267,518)
(5,434,703)	(11,033,258)	(1,691,624)	(22,481,096)	(27,410)	932,613	(39,735,479)

	2014						
	Non-Life Insurance	Life Insurance	Healthcare	Energy	Other	Eliminations	Total
	Rs. '000	Rs. '000	Rs. '000	Rs. '000	Rs. '000	Rs. '000	Rs. '000
Other Revenue							
Investment Income	2,096,374	9,120,198	64,571	235,639	500,627	(308,790)	11,708,618
Fees and Commission Income	-	49,294	-	-	-	-	49,294
Net Realised Gains	(8,270)	(149,467)	5,480	(34)	-	-	(152,291)
Impairment Loss on Available-For-Sale Financial Investments	-	-	-	-	-	-	-
Other Income	136,629	252,315	44,423	455,264	289,896		1,178,527
	2,224,733	9,272,341	114,474	690,869	790,523	(308,790)	12,784,149
Expenses							
Other Operating, Investment Related and Administrative Expenses	(3,492,049)	(2,507,813)	(2,287,230)	(913,018)	(477,866)	81,499	(9,596,477)
Profit before Taxation	1,861,713	2,511,426	521,967	6,229,189	337,617	(308,790)	11,153,122
Income Tax Expense	(217,101)	(899,025)	(8,409)	(1,598,665)	(90,254)		(2,813,454)
Net Profit after Taxation/ Transfer to Shareholders' Fund	1,644,613	1,612,400	513,558	4,630,524	247,363	(308,790)	8,339,668

2013						
Non-Life Insurance Rs. '000	Life Insurance Rs. '000	Healthcare Rs. '000	Energy Rs. '000	Other Rs. '000	Eliminations Rs. '000	Total Rs. '000
2,064,663	7,210,899	-	-	-	(380,436)	8,895,126
16,348	11,533	-	-	-	-	27,881
135,303	(95,397)	-	-	-	-	39,906
(12,671)	-	-	-	-	-	(12,671)
313,156	531,962	29,674	407,574	253,613	(267,441)	1,268,538
2,516,799	7,658,997	29,674	407,574	253,613	(647,877)	10,218,780
(2,851,002)	(2,307,020)	(1,666,456)	(438,185)	246,641	473,975	(6,542,047)
3,736,068	2,618,801	743,509	6,527,238	551,998	(380,436)	13,797,179
(803,033)	(897,006)	(66,738)	(1,727,077)	(149,415)	(15,120)	(3,658,388)
2,933,035	1,721,795	676,771	4,800,162	402,584	(395,556)	10,138,791

7.13.0 SEGMENTAL REVIEW: STATEMENT OF FINANCIAL POSITION

As at 31st December	2014						
	Non-Life Insurance Rs. '000	Life Insurance Rs. '000	Healthcare Rs. '000	Energy Rs. '000	Other Rs. '000	Eliminations Rs. '000	Total Rs. '000
Assets							
Financial Investments	25,168,062	91,456,550	-	-	-	-	116,624,612
Investment in Subsidiaries	19,735,494	1,457,914	-	5,000,000	18,500,000	(44,693,408)	-
Property, Plant & Equipment	8,543,067	42,172	3,659,633	10,625,896	12,712,430	-	35,583,199
Investment Properties	465,231	-	-	-	738,200	-	1,203,431
Leasehold Property	20,806	-	161,581	-	174,616	-	357,003
Intangible Assets	141,336	-	32,455	-	175	2,992,805	3,166,771
Loans to Policyholders	-	1,510,067	-	-	-	-	1,510,067
Reinsurance Receivable	1,177,765	29,080	-	-	-	-	1,206,845
Premium Receivable from Policyholders	2,588,094	270,208	-	-	-	-	2,858,302
Premium Receivable from Agents, Brokers and Intermediaries	-	-	-	-	-	-	-
Deferred Tax Assets	-	86,630	-	-	384	-	87,013
Other Assets	2,062,943	1,606,799	790,208	2,271,501	342,394	(389,468)	6,684,328
Deferred Expenses	261,860	-	-	-	-	-	261,860
Cash and Cash Equivalents	3,130,325	2,638,102	994,939	11,806,979	6,969,093	-	25,539,438
Total Assets	63,294,983	99,097,521	5,638,816	29,704,376	39,437,292	(42,090,071)	195,082,914

2013						
Non-Life Insurance Rs. '000	Life Insurance Rs. '000	Healthcare Rs. '000	Energy Rs. '000	Other Rs. '000	Eliminations Rs. '000	Total Rs. '000
21,128,252	73,643,020	-	-	-	-	94,771,272
16,235,493	1,457,914	-	2,000,000	12,000,000	(31,693,407)	-
8,209,893	55,969	3,226,050	10,121,304	9,199,678	-	30,812,895
549,600	-	-	-	784,045	-	1,333,645
21,075	-	147,717	-	21,680	-	190,473
120,041	-	6,480	-	277	2,992,805	3,119,603
-	1,578,196	-	-	-	-	1,578,196
1,406,265	39,978	-	-	-	-	1,446,243
2,702,387	327,754	-	-	-	-	3,030,141
-	56,469	-	-	407	-	56,876
762,217	2,373,771	652,032	2,618,284	445,403	(473,677)	6,378,029
246,896	-	-	-	-	-	246,897
6,360,906	6,663,628	1,063,877	11,469,132	3,700,449	-	29,257,992
-	-	-	-	-	-	-
57,743,026	86,196,698	5,096,155	26,208,720	26,151,940	(29,174,279)	172,222,260

As at 31st December	2014						
	Non-Life Insurance Rs. '000	Life Insurance Rs. '000	Healthcare Rs. '000	Energy Rs. '000	Other Rs. '000	Eliminations Rs. '000	Total Rs. '000
Liabilities and Equity							
Liabilities							
Insurance Provision – Life	-	77,254,496	-	-	-	-	77,254,468
Insurance Provision – Non-Life	13,195,783	-	-	-	-	-	13,195,783
Reinsurance Payable	1,013,511	-	-	-	-	-	1,013,511
Current Tax Liabilities	162,501	800,664	-	461,057	48,324	-	1,472,546
Deferred Tax Liabilities	743,056	-	314,106	1,774,719	2,747	-	2,834,628
Retirement Benefit Obligations	348,721	319,660	105,320	64,801	34,073	-	872,575
Other Liabilities	1,915,574	1,925,815	538,381	6,603,158	677,753	(417,168)	11,243,513
Financial Liabilities	218,588	170,319	197,730	-	12,691	-	599,328
Total Liabilities	17,597,734	80,470,956	1,155,537	8,903,735	775,588	(417,168)	108,486,380
Equity							
Stated Capital	6,000,000	-	2,671,543	1,947,109	37,870,087	(42,488,739)	6,000,000
Capital Reserve	5,805,655	27,877	1,032,575	3,916,066	-	(1,456,780)	9,325,393
Available-For-Sale Reserve	9,031,976	17,493,276	-	-	-	-	26,525,252
Revenue Reserves	24,859,618	1,105,411	779,161	14,937,466	791,617	(4,973,461)	37,499,812
Non-Controlling Interest	-	-	-	-	-	7,246,077	7,246,077
Total Equity	45,697,249	18,626,565	4,483,279	20,800,641	38,661,704	(41,672,903)	86,596,534
Total Liabilities and Equity	63,294,983	99,097,521	5,638,816	29,704,376	39,437,292	(42,090,071)	195,082,914

2013						
Non-Life Insurance Rs. '000	Life Insurance Rs. '000	Healthcare Rs. '000	Energy Rs. '000	Other Rs. '000	Eliminations Rs. '000	Total Rs. '000
-	69,079,061	-	-	-	-	69,079,061
13,288,956	-	-	-	-	-	13,288,956
878,615	18,467	-	-	-	-	897,082
887,282	852,393	-	1,038,869	-	-	2,778,544
935,656	-	278,099	1,582,042	9,125	-	2,808,369
241,626	221,490	66,880	81,255	23,993	-	635,244
2,368,654	1,523,134	569,291	7,102,121	698,409	(473,675)	11,787,935
232,612	129,109	135,055	-	-	-	496,776
18,833,401	71,823,654	1,049,325	9,804,287	731,527	(473,675)	101,771,969
6,000,000	-	2,671,543	1,947,109	24,870,087	(29,488,739)	6,000,000
5,370,974	40,892	1,020,435	3,893,533	-	(1,599,072)	8,752,043
5,092,637	10,272,074	-	-	-	-	15,364,711
22,446,014	4,060,080	354,852	10,563,791	550,326	(4,667,367)	33,278,963
-	-	-	-	-	7,054,574	7,054,574
38,909,625	14,373,045	4,046,830	16,404,432	25,420,413	(28,700,604)	70,450,291
57,743,026	86,196,699	5,096,155	26,208,720	26,151,939	(29,174,279)	172,222,260

7.14.0 NOTES TO THE FINANCIAL STATEMENTS

FOR THE YEAR ENDED 31ST DECEMBER 2014

1. REPORTING ENTITY

1.1 CORPORATE INFORMATION

Sri Lanka Insurance Corporation Ltd. (‘the Company’) is a public limited liability company incorporated and domiciled in Sri Lanka. The registered office of the Company is located in the District of Colombo and the principal place of business is located at ‘Rakshana Mandiraya,’ No. 21, Vauxhall Street, Colombo 02. All companies in the Group are limited liability companies incorporated and domiciled in Sri Lanka. The Consolidated Financial Statements of the Company as at and for the year ended 31st December 2014 comprise the Company and its subsidiaries Management Services Rakshana (Private) Ltd., The Lanka Hospitals Corporation PLC, Litro Gas Lanka Ltd., Litro Gas Terminal Lanka (Pvt) Ltd., Canwill Holdings (Pvt) Ltd. and Canowin Hotels and Spas (Pvt) Ltd. (Together referred to as the ‘Group’ and individually as ‘Group entities’). 599,598,516 number of ordinary shares (99.97%) of the Parent Company is owned by Secretary to the Treasury and rest owned by employees and ex-employees of the Company.

1.2 PRINCIPAL ACTIVITIES AND NATURE OF OPERATIONS

The principal activities of the Group are to undertake and carry on all classes of insurance businesses, health care services, provide bulk storage facilities for Liquid Petroleum Gas (LPG) and to import, process, store, distribute and sell Liquid Petroleum Gas (LPG), provide other incidental services, investment promotion in relation to leisure sector and controlling and monitoring subsidiaries as a holding company and engage in business of hospitality trade.

1.3 RESPONSIBILITY FOR FINANCIAL STATEMENTS

The Board of Directors is responsible for the preparation and presentation of these Financial Statements.

2. BASIS OF PREPARATION

2.1 STATEMENT OF COMPLIANCE

The Financial Statements have been prepared in accordance with Sri Lanka Accounting Standards SLFRS/LKAS as issued by The Institute of Chartered Accountants of Sri Lanka and comply with the requirements of the Companies Act No. 07 of 2007, the Regulation of Insurance Industry Act No. 43 of 2000.

2.2 BASIS OF MEASUREMENT

The Financial Statements have been prepared on the historical cost basis except for the following material items in the Statement of Financial Position:

- Assets held-for-trading are measured at fair value
- Financial instruments designated at 'Fair-Value-Through-Profit-or-Loss' are measured at fair value
- Available-For-Sale financial assets are measured at fair value
- Land and buildings are measured at revalued amounts
- Policyholders' liability have been measured at actuarial-determined values
- The liability for defined benefit obligations are actuarially valued and recognised as the present value of the defined benefit obligation.

2. BASIS OF PREPARATION

2.1 BASIS OF MEASUREMENT

The Group presents its Statement of Financial Position broadly in the order of liquidity.

Financial assets and financial liabilities are offset and the net amount reported in the Statement of Financial Position only when there is a legal enforceable right to offset the recognised amounts and there is an intention to settle on a net basis, or to realise the assets and settle the liabilities simultaneously.

2.2 SUPPLEMENTARY STATEMENTS – STATEMENT OF FINANCIAL POSITION OF LIFE INSURANCE

Supplementary Statement of Financial Position of the Life Insurance Fund together with the notes are disclosed continuing the past practice which is a requirement of the Statement of Recommended Practice (SORP) for insurance contracts then applicable, adopted by The Institute of Chartered Accountants of Sri Lanka.

2.3 FUNCTIONAL AND PRESENTATION CURRENCY

The Financial Statements are presented in Sri Lankan Rupees (Rs.), which is the Group's functional currency. Except as indicated, financial information presented in Sri Lankan Rupees has been rounded to the nearest thousand.

2.4 USE OF ESTIMATES AND JUDGMENTS

The preparation of the Financial Statements in conformity with SLFRS requires management to make judgments, estimates and assumptions that affect the application of accounting policies and the reported amounts of assets, liabilities, income and expenses. Actual results may differ from estimates.

Estimates and underlying assumptions are based on historical experience and various other factors, including expectations of future events that are believed to be reasonable under the circumstances.

Estimates and underlying assumptions are reviewed on an ongoing basis. Revisions to accounting estimates are recognised in the period in which the estimates are revised and in any future periods which are affected.

Information about assumptions and estimation uncertainties in applying accounting policies that have the most significant effect on the amounts recognised in the Financial Statements are included in the Notes to the Financial Statements.

2.5 MATERIALITY AND AGGREGATION

Each material class of similar items is presented separately in the Financial Statements. Items of dissimilar nature or function are presented separately unless they are immaterial.

2.6 COMPARATIVE INFORMATION

The presentation and classification of the Financial Statements of the previous years have been amended, where relevant for better presentation and to be comparable with those of the current year.

2.7 GOING CONCERN

The Directors have made an assessment of the Group's ability to continue as a going concern, and being satisfied that it has the resources to continue in business for the foreseeable future. Furthermore, Directors are not aware of any material uncertainties that may cast significant doubt upon the Group's ability to continue as a going concern. Therefore, the Financial Statements continue to be prepared on the going concern basis.

2.8 DATE OF AUTHORISATION OF ISSUE

The Financial Statements were authorised for issue by the Board of Directors on 1st June 2015.

3. SIGNIFICANT ACCOUNTING POLICIES

The accounting policies set out below have been applied consistently to all periods presented in these Financial Statements unless otherwise indicated.

3.1 BASIS OF CONSOLIDATION

(I) BUSINESS COMBINATIONS

Business combinations are accounted for using the acquisition method as at the acquisition date, which is the date on which control is transferred to the Group. Control is the power to govern the financial and operating policies of an entity so as to obtain benefits from its activities. In assessing control, the Group takes into consideration potential voting rights that currently are exercisable.

The Group measures goodwill at the acquisition date as:

- the fair value of the consideration transferred; plus
- the recognised amount of any non-controlling interest in the acquiree; plus
- if the business combination is achieved in stages, the fair value of the pre-existing equity interest in the acquiree; less
- the net recognised amount (generally fair value) of the identifiable assets acquired and liabilities assumed.

When the excess is negative, a bargain purchase gain is recognised immediately in profit and loss.

The consideration transferred does not include amounts related to the settlement of pre-existing relationships. Such amounts generally are recognised in profit and loss.

Transactions costs, other than those associated with the issue of debt or equity securities, that the Group incurs in connection with a business combination are expensed as incurred.

(II) ACQUISITIONS OF NON-CONTROLLING INTEREST

Acquisitions of non-controlling interest are accounted for as transactions with owners in their capacity as owners and therefore no goodwill is recognised as a result. Adjustments to non-controlling interest arising from transactions that do not involve the loss of control are based on a proportionate amount of the net assets of the subsidiary.

(III) SUBSIDIARIES

Subsidiaries are entities controlled by the Group. The Financial Statements of subsidiaries are included in the Consolidated Financial Statements from the date that control commences until the date that control ceases.

(IV) LOSS OF CONTROL

On the loss of control, the Group derecognises the assets and liabilities of the subsidiary, any non-controlling interest and the other components of equity related to the subsidiary. Any surplus or deficit arising on the loss of control is recognised in profit and loss. If the Group retains any interest in the previous subsidiary, then such interest is measured at fair value at the date that control is lost. Subsequently it is accounted for as an equity-accounted investee or as an available-for-sale financial asset depending on the level of influence retained.

(V) TRANSACTIONS ELIMINATED ON CONSOLIDATION

Intra-group balances and transactions, and any unrealised income and expenses arising from intra-group transactions, are eliminated in preparing the Consolidated Financial Statements. Unrealised gains arising from transactions with equity-accounted investees are eliminated against the investment to the extent of the Group's interest in the investee. Unrealised losses are eliminated in the same way as unrealised gains, but only to the extent that there is no evidence of impairment.

3.2 FOREIGN CURRENCY TRANSACTIONS

Transactions in foreign currencies are translated to the functional currencies of the Group at exchange rates at the dates of transactions. Monetary assets and liabilities denominated in foreign currencies at the reporting date are retranslated to the functional currency at the exchange rate at that date.

The foreign currency gain or loss on monetary items is the difference between amortised cost in the functional currency at the beginning of the period, adjusted for effective interest and payments during the period, and the amortised cost in foreign currency translated at the exchange rate at the end of the reporting period.

Non-monetary assets and liabilities denominated in foreign currencies that are measured at fair value are retranslated to the functional currency at the exchange rate at the date that the fair value was determined. Non-monetary items that are measured in terms of historical cost in a foreign currency are translated using the exchange rate at the date of transaction.

Foreign currency differences arising on retranslation are recognised in profit and loss, except for differences arising on the retranslation of available-for-sale equity instruments, which are recognised in Profit or Loss and Other Comprehensive Income.

3.3 INSURANCE CONTRACTS

As permitted by SLFRS 4 – ‘Insurance Contracts’, the Group continues to apply the existing accounting policies for insurance contracts that were applied prior to the adoption of SLFRS.

3.3.1 PRODUCT CLASSIFICATION

SLFRS 4 requires contracts written by insurers to be classified as either ‘insurance contracts’ or ‘investment contracts’ depending on the level of insurance risk transferred.

Insurance contracts are those contracts when the Group (the insurer) has accepted significant insurance risk from another party (the policyholders) by agreeing to compensate the policyholders if a specified uncertain future event (the insured event) adversely affects the policyholders. As a general guideline, the Group determines whether it has significant insurance risk, by comparing benefits paid with benefits payable if the insured event did not occur. Insurance contracts can also transfer financial risk.

Investment contracts are those contracts that transfer significant financial risk and non significant insurance risk. Financial risk is the risk of a possible future change in one or more of a specified interest rate, financial instrument price, commodity price, foreign exchange rate, index of price or rates, credit rating or credit index or other variable, provided in the case of a non-financial variable that the variable is not specific to a party to the contract.

Once a contract has been classified as an insurance contract, it remains an insurance contract for the remainder of its lifetime, even if the insurance risk reduces significantly during this period, unless all rights and obligations are extinguished or expired. Investment contracts can, however, be reclassified as insurance contracts after inception if insurance risk becomes significant.

All the products sold by the Group are insurance contracts and therefore classified as insurance contracts under SLFRS 4 – ‘Insurance Contracts’. Thus, the Group does not have any investment contracts within its product portfolio as at the reporting date.

3.4 INTANGIBLE ASSETS

3.4.1 GOODWILL

Goodwill that arises on the acquisition of the subsidiaries is presented with intangible assets. The measurement of goodwill at initial recognition is given in Note 3.1. (I) to the Financial Statements.

3.4.1.2 IMPAIRMENT OF GOODWILL

Goodwill is tested for impairment annually (as at 31st December) and when circumstances indicate that the carrying value may be impaired. Impairment is determined for goodwill by assessing the recoverable amount of each cash-generating unit to which the goodwill relates. Where the recoverable amount of the cash-generating unit is less than their carrying amount, an impairment loss is recognised in profit and loss. Impairment losses relating to goodwill cannot be reversed in the future.

OTHER INTANGIBLE ASSETS

Other intangible assets that have finite useful lives are measured at cost less accumulated amortisation and accumulated impairment losses.

3.4.2 SOFTWARE

3.4.2.1 BASIS OF RECOGNITION

An intangible asset is recognised if it is probable that future economic benefits that are attributable to the asset will flow to the Group and the cost of the asset can be measured reliably.

3.4.2.2 BASIS OF MEASUREMENT

Intangible assets acquired separately are measured as initial recognition at cost. Following initial recognition intangible assets are carried at cost or any accumulated amortisation and any accumulated impairment losses. The intangible assets with finite useful life are amortised over the useful life and assessed for impairment whenever there is an indication that intangible assets may be impaired. Intangible assets with indefinite useful lives are tested for impairment annually either individually or at the Cash Generating Unit (CGU) level.

3.4.2.3 SUBSEQUENT MEASUREMENT

Subsequent expenditure on software assets is capitalised only when it increases the future economic benefits embodied in the specific asset to which it relates. All other expenditure is expensed as incurred.

3.4.2.4 AMORTISATION

Amortisation is recognised in profit or loss on a straight-line basis over the estimated useful life of the software, from the date that it is available for use since this most closely reflects the expected pattern of consumption of the future economic benefits embodied in the asset. The estimated useful life of software is six years.

Amortisation methods and useful lives are reviewed at each financial year end and adjusted if appropriate.

3.4.2.5 DERECOGNITION

An intangible asset is derecognised on disposal or when no future economic benefits are expected from it. The gain or loss arising from the derecognition of such intangible assets is included in profit or loss when the item is derecognised.

3.5 PROPERTY, PLANT & EQUIPMENT

3.5.1 BASIS OF RECOGNITION AND MEASUREMENT

Items of property, plant & equipment are measured at cost/revaluation less accumulated depreciation and accumulated impairment losses.

Cost includes expenditure that is directly attributable to the acquisition of the asset. The cost of self-constructed assets includes the following:

- the cost of materials and direct labour;
- any other costs directly attributable to bringing the assets to a working condition for their intended use;
- when the Group has an obligation to remove the asset or restore the site, an estimate of the costs of dismantling and removing the items and restoring the site on which they are located.

Purchased software that is integral to the functionality of the related equipment is capitalised as part of that equipment. When parts of an item of property, plant & equipment have different useful lives, they are accounted for as separate items (major components) of property, plant & equipment.

Any gain or loss on disposal (calculated as the difference between the net proceeds from disposal and the carrying amount of the item) is recognised in other operating income in profit and loss. When revalued assets are sold, any related amount included in the revaluation surplus reserves are transferred to retained earnings.

3.5.2 SUBSEQUENT COSTS

The cost of replacing a part of an item of plant and equipment is recognised in the carrying amount of the item if it is probable that the future economic benefits embodied within the part will flow to the Group and its cost can be measured reliably. The cost of day-to-day servicing of property, plant & equipment is expensed as incurred.

3.5.3 REVALUATIONS

Land and buildings are measured at fair value less accumulated depreciation on buildings and impairment losses are recognised after the date of the revaluation. Valuations are performed to ensure that the fair value of a revalued asset does not differ materially from its carrying amount.

Any revaluation surplus is recognised in Profit or Loss and Other Comprehensive Income and accumulated in equity in the revaluation reserve, except to the extent that it reverse a revaluation decrease of the same asset previously recognised in profit and loss, in which case the increase is recognised in profit and loss. A revaluation deficit is recognised in profit and loss, except to the extent that it offsets an existing surplus on the same asset recognised in the asset revaluation reserve.

Additionally, accumulated depreciation as at the revaluation date is eliminated against the gross carrying amount of the asset and the net amount is restated to the revalued amount of the asset. Upon disposal, any revaluation reserve relating to the particular asset being sold is transferred to retained earnings.

3.5.4 DEPRECIATION

Items of property, plant & equipment are depreciated on a straight-line basis in profit and loss over the estimated useful of each component.

Items of property, plant & equipment are depreciated from the date that they are installed and are ready for use, or in respect of internally constructed assets, from the date that the asset is completed and ready for use.

The estimated useful lives for the current and comparative years are as follows:

Buildings	20 years
Furniture & Fittings	10 years
Electrical Generators	10 years
Office & Other Equipment	10 years
Air Condition Plant	10 years
Passenger Lifts	6 2/3 years
Electrical Fixtures & Fittings	6 2/3 years
Computers and Computer Equipment	4 years
Motor Vehicles	4 years

3.5.5 DERECOGNITION

The carrying amount of an item of property, plant & equipment is derecognised on disposal or when no future economic benefits are expected from it. The gain or loss arising from the derecognition of an item of property, plant & equipment is included in profit and loss when the item is derecognised.

3.5.6 CAPITAL WORK-IN-PROGRESS

Capital work-in-progress is stated at cost. These are expenses of a capital nature directly incurred on property, plant & equipment, awaiting capitalisation.

3.5.7 LEASED ASSETS – LESSEE

The determination of whether an arrangement is a lease, or contains a lease, is based on the substance of the arrangement at the inception date.

LEASED ASSETS

Leases in terms of which the Group assumes substantially all of the risks and rewards of ownership are classified as finance leases. On initial recognition, the leased asset is measured at an amount equal to the lower of its fair value and the present value of the minimum lease payments. Subsequent to initial recognition, the asset is accounted for in accordance with the accounting policy applicable to that asset.

OPERATING LEASE

Leases that do not transfer to the Group substantially all the risks and benefits incidental to ownership of the leased items are operating leases. Operating lease payments are recognised as an expense in profit and loss on a straight-line basis over the lease term.

3.6 IMPAIRMENT OF NON-FINANCIAL ASSETS

The carrying amounts of the Group's non-financial assets, other than deferred tax assets, are reviewed at each reporting date to determine whether there is any indication of impairment. If any such indication exists, then the asset's recoverable amount is estimated. For intangible assets that have indefinite useful lives or that are not yet available for use, the recoverable amount is estimated each year at the same time. An impairment loss is recognised if the carrying amount of an asset or CGU exceeds its estimated recoverable amount.

The recoverable amount of an asset or CGU is the greater of its value in use and its fair value less costs to sell. In assessing value in use, the estimated future cash flows are discounted to their present value using a pre-tax discount rate that reflects current market assessments of the time value of money and the risks specific to the asset or CGU. For the purpose of impairment testing, assets that cannot be tested individually are grouped together into the smallest group of assets that generates cash inflows from continuing use that are largely independent of the cash inflows of other assets.

Impairment losses are recognised in profit and loss.

3.7 FINANCIAL INSTRUMENTS

3.7.1 NON-DERIVATIVE FINANCIAL ASSETS

3.7.1.1 INITIAL RECOGNITION AND MEASUREMENT

The Group initially recognises loans and receivables and deposits on the date at which they are originated. All other financial assets and liabilities (including assets and liabilities designated at Fair-Value-Through-Profit-or-Loss) are initially recognised on the trade date at which the Group becomes a party to the contractual provisions of the instrument.

A financial asset or financial liability is measured initially at fair value plus, for an item not at Fair-Value-Through-Profit-or-Loss, transaction costs that are directly attributable to its acquisition or issue.

At inception a financial asset is classified into one of the following categories:

- Fair-Value-Through-Profit-or-Loss (FVTPL);
- Loans and Receivables (L&R);
- Held-To-Maturity (HTM); and
- Available-For-Sale (AFS) as appropriate.

The Group determines the classification of its financial assets at initial recognition.

The classification depends on the purpose for which the investments were acquired or originated (i.e. intention) and based on the Group's ability. Financial assets are classified as at Fair-Value-Through-Profit-or-Loss where the Group's investment strategy is to manage financial investments on a fair value basis. The Available-For-Sale and Held-To-Maturity categories are used when the relevant liability (including shareholders' funds) is passively managed and/or carried at amortised cost.

Purchases or sales of financial assets that require delivery of assets within a time frame established by regulation or convention in the marketplace are recognised on the settlement date, i.e. the date that the Group receives/settles money for the sale/purchase of the financial asset. However, when it comes to investment in quoted equities and quoted corporate debt, the transaction date (i.e. trade date) is used to recognise/derecognise the asset.

The Group's existing types of financial assets and their classifications are shown in the table below:

Financial Asset	Category
Treasury Bonds	Available-For-Sale/Held-To-Maturity
Treasury Bills	Available-For-Sale/Held-To-Maturity
Listed Equity Shares	Fair-Value-Through-Profit-or-Loss/Available-For-Sale
Unlisted Equity Shares	Available-For-Sale
Unit Trusts	Available-For-Sale
Listed Corporate Debt	Available-For-Sale
Unlisted Corporate Debt	Loans and Receivables
Term Deposits	Loans and Receivables
Trust Certificates	Loans and Receivables
Development Bonds	Loans and Receivables
Commercial Papers	Loans and Receivables
Policy Loans	Loans and Receivables
Staff and Advisor Loans	Loans and Receivables

3.7.1.2 SUBSEQUENT MEASUREMENT

(a) Available-For-Sale Financial Assets (AFS)

Available-For-Sale financial investments include equity and debt securities (Government Securities and Corporate Debt). Equity investments classified as Available-For-Sale are those that are neither classified as Held-To-Maturity nor designated at Fair-Value-Through-Profit-or-Loss. Debt securities in this category are those that are intended to be held for an indefinite period of time and which may be sold in response to needs for liquidity or in response to changes in the market conditions.

After initial measurement, Available-For-Sale financial assets are subsequently measured at fair value, with unrealised gains or losses recognised in Profit or Loss and Other Comprehensive Income in the Available-For-Sale reserve.

Interest earned whilst holding Available-For-Sale investments is reported as 'Interest Income' using the Effective Interest Rate (EIR). Dividends earned whilst holding Available-For-Sale investments are recognised in Profit or Loss as 'Investment Income' when the right of the payment has been established. When the asset is derecognised, the cumulative gain or loss is recognised in the investment income.

If the asset is determined to be impaired, the cumulative loss is recognised in Profit or Loss in the ‘Investment Income’ and removed from the Available-For-Sale reserve.

The Group evaluates its Available-For-Sale financial assets to determine whether the ability and intention to sell them in the near term would still be appropriate. In the case where the Group is unable to trade these financial assets due to inactive markets and management’s intention significantly changes to do so in the foreseeable future, the Group may elect to reclassify these financial assets in rare circumstances. Reclassification to loans and receivables is permitted when the financial asset meets the definition of loans and receivables and management has the intention and ability to hold these assets for the foreseeable future or until maturity. The reclassification to Held-To-Maturity is permitted only when the entity has the ability and intention to hold the financial asset until maturity.

For a financial asset that is reclassified out of the Available-For-Sale category, any previous gain or loss on that asset that has been recognised in equity is amortised to profit or loss over the remaining life of the investment using the EIR. Any difference between the new amortised cost and the expected cash flows is also amortised over the remaining life of the asset using the EIR. If the asset is subsequently determined to be impaired then the amount recorded in equity is reclassified to the Income Statement.

(b) Financial Assets at Fair-Value-Through-Profit-or-Loss (FVTPL)

Financial assets at Fair-Value-Through-Profit-or-Loss include financial assets held for trading and those designated upon initial recognition at Fair-Value-Through-Profit-or-Loss. Investments typically bought with the intention to sell in the near future are classified as held for trading.

For investments designated as at Fair-Value-Through-Profit-or-Loss, the following criteria must be met:

The designation eliminates or significantly reduces the inconsistent treatment that would otherwise arise from measuring the assets or liabilities or recognising gains or losses on a different basis.

The assets and liabilities are part of a Group’s financial assets, financial liabilities, or both, which are managed and their performance evaluated on a fair value basis, in accordance with the Group’s investment strategy.

These investments are initially recorded at fair value. Subsequent to initial recognition, they are remeasured at fair value. Changes in fair value are recorded in ‘Fair value gains and losses’ in profit or loss.

Interest is accrued and presented in ‘Investment Income’ or ‘Finance Cost’, respectively, using the (EIR). Dividend income is recorded in the ‘Investment Income’ when the right to the payment has been established.

The Group evaluates its financial assets at Fair-Value-Through-Profit-or-Loss (held-for-trading) whether the intent to sell them in the near term is still appropriate. When the Group is unable to trade these financial assets due to inactive markets and management’s intent to sell them in the foreseeable future significantly changes, the Group may elect to reclassify these financial assets in rare circumstances. The reclassification to loans and receivables, Available-For-Sale or Held-To-Maturity depends on the nature of the asset.

(c) Held-To-Maturity Financial Assets (HTM)

Non-derivative financial assets with fixed or determinable payments and fixed maturities are classified as Held-To-Maturity when the Group has both the intention and ability to hold until maturity. After initial measurement, Held-To-Maturity financial assets are measured at amortised cost, using the EIR, less impairment.

The EIR amortisation is included in ‘Investment Income’ in the Statement of Income.

Gains and losses are recognised in the profit or loss when the investments are derecognised or impaired, as well as through the amortisation process.

(d) Loans and Receivables – (L & R)

Loans and receivables are non-derivative financial assets with fixed or determinable payments that are not quoted in an active market.

These investments are initially recognised at cost, being the fair value of the consideration paid for the acquisition of the investment. All transaction costs directly attributable to the acquisition are also included in the cost of the investment. After initial measurement, loans and receivables are measured at amortised cost, using the EIR, less allowance for impairment.

Amortised cost is calculated by taking into account any discount or premium if any, on acquisition and fee or costs that are an integral part of the EIR. The EIR amortisation is included in ‘Investment Income’ in profit or loss.

Gains and losses are recognised in the profit or loss when the investments are derecognised or impaired, as well as through the amortisation process.

The fair value of policy loans are estimated by discounting future cash flows using interest rates currently being offered in respect of similar loans. The fair value of fixed rate policy loans are estimated by discounting cash flows at the interest rates charged on policy loans of similar policies currently being issued. The varying values of policy loans with variable rates approximate to their fair value.

(e) Cash and Cash Equivalents

Cash and cash equivalents comprise, reverse repurchase agreements, cash balances and call deposits with maturities of three months or less from the acquisition date that are subject to an insignificant risk of changes in their fair value, and are used by the Group in the management of its short-term commitments.

3.7.1.3 DERECOGNITION

The Group derecognises a financial asset when the contractual rights to the cash flows from the financial asset expire, or when it transfers the financial asset in a transaction in which substantially all the risks and rewards of ownership of the financial asset are transferred or in which the Group neither transfers nor retains substantially all the risks and rewards of ownership and it does not retain control of the financial asset. Any interest in transferred financial assets that qualify for derecognition that is created or retained by the Group is recognised as a separate asset or liability in the Statement of Financial Position. On derecognition of a financial asset, the difference between the carrying amount of the asset (or the carrying amount allocated to the portion of the asset transferred), and consideration received (including any new asset obtained less any new liability assumed) is recognised in profit or loss.

The Group derecognises a financial liability when its contractual obligations are discharged or cancelled or expired.

3.7.2 NON-DERIVATIVE FINANCIAL LIABILITIES

The Group initially recognises debt securities issued and subordinated liabilities on the date that they are originated. All other financial liabilities (including liabilities designated as at Fair-Value-Through-Profit-or-Loss) are recognised initially on the trade date, which is the date that the Group becomes a party to the contractual provisions of the instrument.

The Group derecognises a financial liability when its contractual obligations are discharged, cancelled or expire.

The Group classifies non-derivative financial liabilities into the other financial liabilities category. Such financial liabilities are recognised initially at fair value less any directly attributable transaction costs. Subsequent to initial recognition, these financial liabilities are measured at amortised cost using the effective interest method.

Other financial liabilities comprise loans and borrowings, bank overdrafts and trade & other payables.

Bank overdrafts that are repayable on demand and form an integral part of the Group's cash management are included as a component of cash and cash equivalents for the purpose of the Statement of Cash Flows.

3.7.3 STATED CAPITAL ORDINARY SHARES

Ordinary shares are classified as equity. Incremental costs directly attributable to the issue of ordinary shares are recognised as a deduction from equity, net of any tax effects.

3.7.4 AMORTISED COST MEASUREMENT

The amortised cost of a financial asset or liability is the amount at which the financial asset or liability is measured at initial recognition, minus principal repayments, plus or minus the cumulative amortisation using the effective interest method of any difference between the initial amount recognised and the maturity amount, minus any reduction for impairment.

3.7.5 FAIR VALUE MEASUREMENT

Fair value is the amount for which an asset could be exchanged, or a liability settled, between knowledgeable, willing parties in an arm's length transaction on the measurement date.

When available, the Group measures the fair value of an instrument using quoted prices in an active market for that instrument (Categorised as Level 1). A market is regarded as active if quoted prices are readily and regularly available and represent actual and regularly occurring market transactions on an arm's length basis.

If a market for a financial instrument is not active, then the Group establishes fair value using a valuation technique (Categorised as Level 2). Valuation techniques include using recent arm's length transactions between knowledgeable, willing parties (if available), reference to the current fair value of other instruments that are substantially the same, discounted cash flow analyses and option pricing models.

For discounted cash flow techniques, estimated future cash flows are based on management's best estimates and the discount rate used is a market-related rate for a similar instrument. The use of different pricing models and assumptions could produce materially different estimates of fair values.

If the fair value cannot be measured reliably, these financial instruments are measured at cost, being the fair value of the consideration paid for the acquisition of the investment or the amount received on issuing the financial liability (Categorised as Level 3). All transaction costs directly attributable to the acquisition are also included in the cost of the investment.

The best evidence of the fair value of a financial instrument at initial recognition is the transaction price, i.e., the fair value of the consideration given or received, unless the fair value of that instrument is evidenced by comparison with other observable current market transactions in the same instrument, i.e., without modification or repackaging or based on a valuation technique whose variables include only data from observable markets. When transaction price provides the best evidence of fair value at initial recognition, the financial instrument is initially measured at the transaction price and any difference between this price and the value initially obtained from a valuation model is subsequently recognised in profit or loss on an appropriate basis over the life of the instrument but not later than when the valuation is supported wholly by observable market data or the transaction is closed out.

3.7.6 IDENTIFICATION AND MEASUREMENT OF IMPAIRMENT

The Group assesses at each reporting date whether there is any objective evidence that a financial asset or group of financial assets is impaired. A financial asset or a group of financial assets is deemed to be impaired if, and only if, there is objective evidence of impairment as a result of one or more events that has occurred after the initial recognition of the asset (an incurred 'loss event') and that loss event has an impact on the estimated future cash flows of the financial asset or the group of financial assets that can be reliably estimated.

Evidence of impairment may include indications that the debtors or a group of debtors is experiencing significant financial difficulty, default or delinquency in interest or principal payments, the probability that they will enter bankruptcy or other financial reorganisation and where observable data indicate that there is a measurable decrease in the estimated future cash flows, such as changes in arrears or economic conditions that correlate with defaults.

3.7.6.1 FINANCIAL ASSETS CARRIED AT AMORTISED COST

For financial assets carried at amortised cost, the Group first assesses individually whether objective evidence of impairment exists individually for financial assets that are individually significant, or collectively for financial assets that are not individually significant.

If the Group determines that no objective evidence of impairment exists for an individually assessed financial asset, whether significant or not, it includes the asset in a group of financial assets with similar credit risk characteristics and collectively assesses them for impairment.

Assets that are individually assessed for impairment and for which an impairment loss is, or continues to be recognised are not included in a collective assessment of impairment.

If there is objective evidence that an impairment loss on assets carried at amortised cost has been incurred, the amount of the loss is measured as the difference between the carrying amount of the asset and the present value of estimated future cash flows (excluding future expected credit losses that have not been incurred) discounted at the financial asset's original effective interest rate. If a loan has a variable interest rate, the discount rate for measuring any impairment loss is the current effective interest rate.

The carrying amount of the asset is reduced through the use of an allowance account and the amount of the loss is recognised in Profit or Loss. Interest income continues to be accrued on the reduced carrying amount and is accrued using the rate of interest used to discount the future cash flows for the purpose of measuring the impairment loss. The interest income is recorded as a part of investment income in the Statement of Comprehensive Income.

Loans together with the associated allowance are written off when there is no realistic prospect of future recovery and all collateral has been realised or has been transferred to the Group. If, in a subsequent year, the amount of the estimated impairment loss increases or decreases because of an event occurring after the impairment was recognised, the previously recognised impairment loss is increased or reduced by adjusting the allowance account. If a future write-off is later recovered, the recovery is credited to the 'Investment Income' in the Statement of Comprehensive Income.

The Group has not experienced any indication of impairment and thus no impairment losses were recognised during the financial year.

3.7.6.2 AVAILABLE-FOR-SALE FINANCIAL ASSETS (AFS)

For Available-For-Sale financial assets, the Group assesses at each reporting date whether there is objective evidence that an investment or a group of investments is impaired.

In the case of debt instruments classified as Available-For-Sale, impairment is assessed based on the same criteria as financial assets carried at amortised cost. However, the amount recorded for impairment is the cumulative loss measured as the difference between the amortised cost and the current fair value, less any impairment loss on that investment previously recognised in the Statement of Income.

Future interest income continues to be accrued based on the reduced carrying amount of the asset and is accrued using the rate of interest used to discount the future cash flows for the purpose of measuring the impairment loss. The interest income is recorded as part of 'Investment Income'. If, in a subsequent year, the fair value of a debt instrument increases and the increase can be objectively related to an event occurring after the impairment loss was recognised in the Statement of Income, the impairment loss is reversed through the Income Statement.

3.7.7 OFFSETTING OF FINANCIAL INVESTMENTS

Financial assets and financial liabilities are offset and the net amount reported in the Statement of Financial Position only when there is a legally enforceable right to offset the recognised amounts and there is an intention to settle on a net basis, or to realise the assets and settle the liability simultaneously.

3.8 DEFERRED EXPENSES

3.8.1 DEFERRED ACQUISITION COSTS (DAC)

Those direct and indirect costs incurred during the financial period arising from the writing or renewing of insurance contracts are deferred and amortised over the period in which the related revenues are earned. All other acquisition costs are recognised as an expense when incurred.

The DAC is applicable only to Non-Life Insurance Contracts. No DAC is calculated for Life Insurance Contracts as the acquisition costs are incurred in line with the revenues earned.

In line with the available regulatory Guidelines from the Insurance Board of Sri Lanka (IBSL), the DAC is calculated based on the 365 basis.

An impairment review is performed at each reporting date or more frequently when an indication of impairment arises. When the recoverable amount is less than the carrying amount, an impairment loss is recognised in the Statement of Comprehensive Income. No such indication of impairment was experienced during the year.

DAC is derecognised when the related contracts are either settled or disposed of.

3.9 REINSURANCE

Group cedes insurance risk in the normal course of business to recognised reinsurers through formal reinsurance arrangements.

Reinsurance assets include the balances due from reinsurance companies for paid and unpaid losses and loss adjustment expenses. Amounts recoverable from reinsurers are estimated in a manner consistent with the outstanding claims provision or settled claims associated with the reinsurer's policies and are in accordance with the related reinsurance contract.

Reinsurance is recorded gross in the Statement of Financial Position unless a right to offset exists.

Reinsurance assets are reviewed for impairment at each reporting date, or more frequently, when an indication of impairment arises during the reporting year. Impairment occurs when there is objective evidence as a result of an event that occurred after initial recognition of the reinsurance asset that the Group may not receive all outstanding amounts due under the terms of the contract and the event has a reliably measurable impact on the amounts that the Group will receive from the reinsurer. The impairment loss, if any is recorded in profit and loss.

Ceded reinsurance arrangements do not relieve the Group from its obligations to policyholders.

Reinsurance assets or liabilities are derecognised when the contractual rights are extinguished or expire or when the contract is transferred to another party.

3.10 PREMIUM RECEIVABLE

Insurance receivables are recognised when due and measured on initial recognition at the fair value of the consideration receivable. Collectability of premiums is reviewed on an ongoing basis.

According to the Premium Payment Warranty (PPW) directive issued by the Insurance Board of Sri Lanka (IBSL), all non-life insurance policies are issued subject to PPW and are cancelled upon the expiry of 60 days if not settled.

The Group account for life insurance premiums on accrual basis with the implementation of SLFRS/LKAS. Accordingly, due Life Insurance premiums (only the premiums due in the 30-day grace period) are recognised at each reporting date and will be reversed if the premiums are not settled during the subsequent month, and thus the policies will be lapsed as per the Group policy.

Reinsurance Commission - Unearned Commission Reserve (UCR) – Non-Life.

3.11 OTHER ASSETS

3.11.1 OTHER RECEIVABLES AND DUES FROM RELATED PARTIES

Other receivables and dues from related parties are recognised at cost less allowances for bad and doubtful receivables.

3.11.2 INVENTORIES

Inventories include all consumable items which are stated at lower of cost and net realisable value.

LIABILITIES AND PROVISIONS

3.12 INSURANCE CONTRACT LIABILITIES

3.12.1 INSURANCE PROVISION - LIFE INSURANCE

Life insurance liabilities are recognised when contracts are entered into and premiums are charged. These liabilities are measured by using the net premium method as specified by the Insurance Board of Sri Lanka (IBSL) based on the recommendation of the Independent Consultant Actuary. The liability is determined as the sum of the discounted value of the expected future benefits, less the discounted value of the expected future premiums that would be required to meet the future cash outflows based on the valuation assumptions used. The liability is computed based on IBSL specified guidelines and current assumptions which vary based on the contract type.

Furthermore, adjustments are performed to capture the likely liabilities that may arise due to currently lapsed contracts reviving in the future.

As required by the SLFRS 4 – ‘Insurance Contracts’, the Group performed a Liability Adequacy Test (LAT) in respect of life insurance contract liabilities with the assistance of an external actuary. In performing the liability adequacy test, current best estimates of future contractual cash flows, including related cash flows such as claims handling and policy administration expenses, policyholder options and guarantees, as well as investment income from assets backing such liabilities, are used.

3.12.2 INSURANCE PROVISION - NON-LIFE INSURANCE

Non-life insurance contract liabilities include the outstanding claims provision including IBNR and IBNER, the provision for unearned premium and the provision for premium deficiency.

The outstanding claims provision is based on the estimated ultimate cost of all claims incurred but not settled at the reporting date, whether reported or not, together with related claims handling costs and reduction for the expected value of salvage and other recoveries. Delays can be experienced in the notification and settlement of certain types of claims, therefore, the ultimate cost of these cannot be known with certainty at the reporting date.

The valuation of Unearned Premium Reserve are measured in accordance with Guidelines of the Regulation of Insurance Industry Act No. 43 of 2000 (i.e. based on the 365 basis).

The Incurred But Not Reported (IBNR) and Incurred But Not Enough Reported (IBNER) claims reserve are actuarially computed.

No provision for equalisation or catastrophe reserves is recognised. The liabilities are derecognised when the obligation to pay a claim expires, is discharged or is cancelled.

As required by the SLFRS 4 - 'Insurance Contracts', the Group performed a Liability Adequacy Test (LAT) in respect of non-life insurance contract liabilities with the assistance of the external actuary.

3.12.3 TITLE INSURANCE RESERVE

Title insurance reserve is maintained by the Group to pay potential claims arising from the title insurance policies. Title insurance policies are normally issued for a long period such as 5 years or more. Thus, no profit is recognised in the first year of the policy given the higher probability of claims occurring in that year. From the 2nd year onwards, profit is recognised by amortising the premium received and will be distributed throughout the remaining period of the policy using the straight-line method. Profit for the first year will only be recognised in the 2nd year and thereafter it is periodically recognised.

If the corresponding loan of the Title Insurance Policy issued is settled before the maturity, full premium of such policies remaining as at the date of settlement of such loan is recognised in profit and loss upon confirmation of the same by the respective Bank.

3.13 EMPLOYEE BENEFITS

3.13.1 SHORT-TERM BENEFITS

Short-term employee benefit obligations are measured on an undiscounted basis and are expensed as the related service is provided. A liability is recognised for the amount expected to be paid under short-term cash bonus or profit-sharing plans if the Group has a present legal or constructive obligation to pay this amount as a result of past service provided by the employee and the obligation can be estimated reliably.

3.13.2 DEFINED CONTRIBUTION PLANS

A defined contribution plan is a post-employment benefit plan under which an entity pays fixed contributions into a separate entity and will have no legal or constructive obligation to pay further amounts. Obligations for contributions to defined contribution plans are recognised as an expense in profit and loss when incurred.

EMPLOYEES' PROVIDENT FUND

All employees of the Group are members of the Employees' Provident Fund (EPF). The Group and employees contribute 15% and 10% respectively of the salary to EPF.

EMPLOYEES' TRUST FUND

All employees of the Group are members of the Employees' Trust Fund (ETF). The Group contributes 3% of the salary of each employee to ETF.

3.13.3 DEFINED BENEFIT PLANS

A defined benefit plan is a post-employment benefit plan other than a defined contribution plan. The liability recognised in the Financial Statements in respect of defined benefit plans is the present value of the defined benefit obligation as at the reporting date. The defined benefit obligation is calculated by a qualified actuary as at the reporting date using the Projected Unit Credit (PUC) method as recommended by LKAS 19 - 'Employee Benefits'. The actuarial valuation involves making assumptions about discount rate, salary increment rate and balance service period of employees. Due to the long-term nature of the plans such estimates are subject to significant uncertainty.

Under the Payment of Gratuity Act No. 12 of 1983, the liability to an employee arises only on completion of 5 years of continued service.

The liability is not externally funded.

ACTUARIAL GAINS AND LOSSES

The remeasurement of the net defined benefit obligation, which comprises actuarial gains and losses are recognised immediately in Other Comprehensive Income.

3.14 PROVISIONS

A provision is recognised if, as a result of a past event, the Group has a present legal or constructive obligation that can be estimated reliably, and it is probable that an outflow of economic benefits will be required to settle the obligation. Provisions are determined by discounting the expected future cash flows at a pre-tax rate that reflects current market assessments of the time value of money and, where appropriate, the risks specific to the liability.

3.15 REVENUE RECOGNITION

3.15.1 INSURANCE PREMIUMS

3.15.1.1 LIFE INSURANCE BUSINESS

Gross recurring premiums on life insurance contracts are recognised as revenue when payable by the policyholder (policies within the 30-day grace period are considered as due). Any premiums received in advance is not recorded as revenue and recorded as a liability until the premium is due. Benefits and expenses are provided against such revenue to recognise profits over the estimated life of the policies.

For single premium business, revenue is recognised on the date on which the policy is effective.

3.15.1.2 NON-LIFE INSURANCE BUSINESS

Gross written premiums – non-life insurance comprises the total premiums received/receivable for the whole period of cover provided by contracts entered into during the accounting period. Gross written premium is generally recognised is written upon inception of the policy. Upon inception of the contract, premiums are recorded as written and are earned primarily on a pro rata basis over the term of the related policy coverage.

Unearned premiums are those proportions of premiums written in a year that relate to periods of risk after the reporting date. Unearned premiums are calculated on 365 basis in accordance with the Regulation of Insurance Industry Act No. 43 of 2000. However, for those contracts for which the period of risk differs significantly from the contract period, premiums are earned over the period of risk in proportion to the amount of insurance protection provided. The proportion attributable to subsequent periods is deferred as a provision for unearned premiums which is included under liabilities.

3.15.2 REINSURANCE PREMIUMS

Gross reinsurance premiums on insurance contracts are recognised as an expense on the earlier of the date when premiums are payable or when the policy becomes effective. Reinsurance premiums are decided based on rates agreed with reinsurers.

Unearned reinsurance premiums are those proportions of premiums written in a year that relate to periods of risk after the reporting date. Unearned reinsurance premiums are deferred over the term of the underlying direct insurance policies for risks-attaching contracts (using 365 basis in accordance with the Regulation of Insurance Industry Act No. 43 of 2000).

3.16 FEES AND COMMISSION INCOME

Insurance and investment contract policyholders are charged for policy administration services and other contract fees. These fees are recognised as revenue upon receipt or becoming due.

3.17 INTEREST

Interest income and expenses are recognised in profit and loss using the effective interest method. The effective interest rate is the rate that exactly discounts the estimated future cash receipts or payments through the expected life of the financial asset or liabilities (or, where appropriate, a shorter period) to the carrying amount of the financial asset or liabilities. When calculating the effective interest rate, the Group estimates future cash flows considering all contractual terms of the financial instrument, but not future credit losses.

The calculation of the effective interest rate includes all transaction costs and fees and points paid or received that are an integral part of the effective interest rate. Transaction costs include incremental costs that are directly attributable to the acquisition or issue of a financial asset or liability.

3.18 DIVIDENDS

Dividend income is recognised when the right to receive income is established. Usually this is the ex-dividend date for equity securities. Dividends are presented in net trading income or net income from other financial instruments at Fair-Value-Through-Profit-or-Loss based on the underlying classification of the equity investment.

3.19 PROFIT/LOSS ON SALE OF PROPERTY, PLANT & EQUIPMENT

Profit/loss on sale of Property, Plant & Equipment is recognised in the period in which the sale occurs and is classified under other income.

3.20 BENEFITS, CLAIMS AND EXPENSES

3.20.1 GROSS BENEFITS AND CLAIMS

3.20.1.1 LIFE INSURANCE BUSINESS

Claims by death and maturity are charged against revenue on notification of death or on expiry of the term. The interim payments and surrenders are accounted for only at the time of settlement.

Expenses on life insurance relates to the acquisition expenses and expenses for maintenance of life insurance business, investment-related expenses not treated as a part of the capital cost of investment, etc., which are accounted on accrual basis.

3.20.1.2 NON-LIFE INSURANCE BUSINESS

Non-life insurance claims include all claims occurring during the year, whether reported or not together with claims handling costs that are directly related to the processing and settlement of claims, a reduction for the value of salvage and other recoveries and any adjustments to claims outstanding from previous years. Claims outstanding are assessed by review of individual claim files and estimating changes in the ultimate cost of settling claims.

The provision in respect of Claims Incurred But Not Reported (IBNR) and Claims Incurred But Not Enough Reported (IBNER) is actuarially valued to ensure a more realistic estimation of the future liability based on the past experience and trends. Actuarial valuations are performed on a semi-annual basis.

Whilst the Directors consider that the provisions for claims are fairly stated on the basis of information currently available, the ultimate liability will vary as a result of subsequent information and events. This may result in adjustments to the amounts provided. Such amounts are reflected in the Financial Statements for that period.

The methods used to estimate claims and the estimates made are reviewed regularly.

3.20.1.3 REINSURANCE CLAIMS

Reinsurance claims are recognised when the related gross insurance claim is recognised according to the terms of the relevant contract.

3.21 NET DEFERRED ACQUISITION EXPENSES

Acquisition expenses, representing commissions, which vary with and are directly related to the production of business, are deferred and amortised over the period in which the related written premiums are earned.

Reinsurance commission is also treated in the same manner within deferred acquisition costs.

3.22 ACTUARIAL VALUATION OF LIFE INSURANCE FUND

The Directors agree to the long-term insurance provision for the Group at the year-end on the recommendations of the Independent Consultant Actuary following his annual investigation of the life insurance business. The actuarial valuation takes into account all liabilities and is based on assumptions recommended by the Independent Consultant Actuary.

3.23 OTHER EXPENSES

Other expenses are recognised on accrual basis. All expenditure incurred in the running of the business and in maintaining the Property, Plant & Equipment has been charged to the Statement of Comprehensive Income.

3.24 INCOME TAX EXPENSE

Income tax expense comprises current and deferred tax. Current and deferred taxes are recognised in profit and loss except to the extent that it relates to items recognised directly in equity, when it is recognised in equity.

3.24.1 CURRENT TAX

Current tax is the expected tax payable on the taxable income for the year, using tax rates enacted or substantively enacted on the reporting date, and any adjustment to tax payable in respect of previous years. Provision for taxation is based on the profit for the year adjusted for taxation purposes in accordance with the provisions of the Inland Revenue Act No. 10 of 2006 and the amendments thereto.

Current income tax assets and liabilities also include adjustments for tax expected to be payable or recoverable in respect of previous periods.

Current income tax relating to items recognised directly in equity or Profit or Loss and Other Comprehensive Income is recognised in equity or Statement of Profit or Loss and Other Comprehensive Income and not in the Statement of Comprehensive Income.

Management periodically evaluates positions taken in the tax returns with respect to situations in which applicable tax regulations are subject to interpretation and establishes provisions, where appropriate.

3.24.2 DEFERRED TAX

Deferred taxation is provided using the liability method, providing for temporary differences between the carrying amounts of assets and liabilities for financial reporting purposes and the tax base of assets and liabilities, which is the amount attributed to those assets and liabilities for tax purposes. The amount of deferred tax provided is based on the expected manner of realisation or settlement of the carrying amount substantively enacted by the reporting date.

Deferred tax liabilities are recognised for all taxable temporary differences. As at the date of the Statement of Financial Position, the Group has deferred tax liabilities arising from Property, Plant & Equipment only.

Deferred tax assets, including those related to temporary tax effects of income tax losses and credits available to be carried forward, are recognised only to the extent that it is probable that future taxable profits will be available against which the asset can be fully utilised. Deferred tax assets, if any, are reviewed at each reporting date and are reduced to the extent that it is no longer probable that the related tax benefit will be realised.

Unrecognised deferred tax assets are reassessed at each reporting date and are recognised to the extent that it has become probable that future taxable profit will allow the deferred tax asset to be recovered.

Deferred tax relating to items recognised outside profit or loss, if any is recognised outside profit or loss. Deferred tax items are recognised in relation to the underlying transaction either in Profit or Loss and Other Comprehensive Income or directly in equity.

Deferred tax assets and deferred tax liabilities are offset, if a legally enforceable right exists to set-off current tax assets against current income tax liabilities and the deferred taxes relate to the same taxable entity and the same taxation authority.

3.24.3 PREMIUM INCOME (GWP) AND OTHER SUNDRY SALES RELATED TAXES

Revenues, expenses and assets are recognised net of the amount of sales taxes and premium taxes except where the premium or sales tax incurred on the purchase of assets or services is not recoverable from the taxation authority, in which case, the sales tax is recognised as a part of the cost of acquisition of the asset or as a part of the expense item, as applicable.

Outstanding net amounts of sales or premium tax recoverable from, or payable to, the taxation authority are included as a part of receivables or payables in the Statement of Financial Position.

3.24.4 WITHHOLDING TAX ON DIVIDENDS

Withholding tax that arises from the distribution of dividends by the Group is recognised at the same time as the liability to pay the related dividend is recognised.

3.24.5 ECONOMIC SERVICE CHARGE (ESC)

As per the provisions of the Economic Service Charge Act No. 13 of 2006, ESC is payable on the liable turnover at specified rates. ESC is deductible from the income tax liability. Any unclaimed receivable ESC amount can be carried forward and set-off against the income tax payable as per the relevant provisions in the Act.

However, with the amendment made by Inland Revenue, if the Group in relation to any relevant quarter commencing on or after 1st April 2012, where such part of the taxable income as consists of profits from any trade, business, profession or vocation assessed under the provisions of Inland Revenue Act No. 10 of 2006 for the year of assessment 2011/12, is more than zero, the relevant turnover for such quarter shall be deemed to be zero.

3.25 SEGMENTAL REPORTING

An operating segment is a component of the Group that engages in business activities from which it may earn revenues and incur expenses, including revenues and expenses that relate to transactions with any of the Group's other components. All operating results are reviewed regularly by the Chief Executive Officer (CEO) to make decisions regarding resources to be allocated to the segments and to assess its performance, and for which discrete finance information is available.

Segment results that are reported to the CEO include items directly attributable to a segment as well as those that can be allocated on a reasonable basis. Accordingly, segmental information of the Group reflects non-life insurance and life insurance. Inter-segment transfers are based on fair market prices.

3.26 EARNINGS PER SHARE (EPS)

The Group presents basic and diluted earnings per share data for its ordinary shareholders. Basic EPS is calculated by dividing the profit or loss attributable to ordinary shareholders of the Group by the weighted average number of ordinary shares determined in accordance with LKAS 33.

3.27 PROPOSED DIVIDENDS

Dividend proposed by the Board of Directors after the reporting date is not recognised as a liability and is only disclosed as a Note to the Financial Statements. Provision for dividend is recognised only at the time the dividend proposed by the Board of Directors is approved by the shareholders at the Annual General Meeting.

3.28 CAPITAL COMMITMENTS AND CONTINGENCIES

All discernible risks are accounted for in determining the amount of all known liabilities. Contingent liabilities are possible obligations whose existence will be confirmed only by uncertain future events or present obligations where the transfer of economic benefit is not probable or cannot be reliably measured. Contingent liabilities are not recognised in the Statement of Financial Position but are disclosed unless they are remote.

3.29 EVENTS OCCURRING AFTER THE REPORTING DATE

All material Post-Statement of Financial Position events have been considered and where appropriate, adjustments or disclosures have been made in the respective Notes to the Financial Statements.

3.30 CASH FLOW STATEMENT

The Cash Flow Statement has been prepared using the indirect method of preparing cash flows in accordance with the Sri Lanka Accounting Standard (LKAS) 7 – ‘Cash Flow Statements’.

Cash and cash equivalents comprise short-term, highly liquid investments that are readily convertible to known amounts of cash and are subject to an insignificant risk of changes in value. The cash and cash equivalents include cash in hand, balances with banks and short-term deposits with banks.

For cash flow purposes, cash and cash equivalents are presented net of bank overdrafts.

4. NEW AND AMENDED STANDARDS AND INTERPRETATIONS ADOPTED DURING THE YEAR

For the first time, the Group applied, the following new Sri Lanka Accounting Standards and amendments which became applicable to the Financial Statements with effect from 1st January 2014.

SLFRS 10 – Consolidated Financial Statements

With the adoption of SLFRS 10, the Group changed its accounting policy for determining whether an investee is a subsidiary based on the definition of control. On adoption of this standard, Group reassessed the control conclusion for its investees.

SLFRS 12 – Disclosure of Interests in Other Entities

SLFRS 12 sets out the requirements for disclosures relating to an entity’s interests in subsidiaries, joint arrangements, associates and structured entities.

SLFRS 13 – Fair Value Measurement

SLFRS 13 establishes a single framework for measuring fair value and making disclosures about fair value measurements, when such measurements are required or permitted by other LKASs.

4.1 STANDARDS ISSUED BUT NOT YET EFFECTIVE

The Institute of Chartered Accountants of Sri Lanka has issued the following new Sri Lanka Accounting Standards which will become applicable for financial periods beginning on or after 1st January 2015. Accordingly, the Group has not applied the following new standards in preparing these Consolidated Financial Statements.

SLFRS 9 – Financial Instruments

SLFRS 9 – ‘Financial Instruments’ replaces the existing guidance in LKAS 39 – Financial Instruments: Recognition and Measurement. SLFRS 9 includes revised guidance on the classification and measurement of financial instruments including a new expected credit loss model for calculating impairment on financial assets. SLFRS 9 is effective for annual period beginning on or after 1st January 2018 with early adoption permitted. The Group is assessing the potential impact on its Consolidated Financial Statements resulting from SLFRS 9.

SLFRS 15 – Revenue from Contracts with Customers

SLFRS 15 – ‘Revenue from Contracts with Customers’ establishes a comprehensive framework for determining whether, how much and when revenue is recognised. It replaces existing revenue recognition guidance LKAS 18 - ‘Revenue’, LKAS 11 - ‘Construction Contracts’. SLFRS - 15 is effective for annual reporting period beginning on or after 1st January 2018, with early adoption permitted.

As at 31st December		2014		2013	
Group/Company	Note	Carrying Value Rs. '000	Fair Value Rs. '000	Carrying Value Rs. '000	Fair Value Rs. '000
5. FINANCIAL INVESTMENTS					
Held-To-Maturity (HTM)					
Financial Assets	5.1	26,076,867	29,832,970	19,324,293	20,708,066
Loans and Receivables (L & R)	5.2	31,740,973	31,738,711	30,048,030	30,043,868
Available-For-Sale (AFS)					
Financial Assets	5.3	53,268,425	53,268,425	39,442,223	39,442,223
Fair-Value-Through-Profit-or-Loss (FVTPL)					
Financial Assets	5.4	5,538,347	5,538,347	5,956,726	5,956,726
Total Financial Investments		116,624,612	120,378,453	94,771,272	96,150,883

5.1 HELD-TO-MATURITY (HTM) FINANCIAL ASSETS

Treasury Bills		487,576	490,450	-	-
Treasury Bonds		25,589,291	29,342,520	19,324,293	20,708,066
		26,076,867	29,832,970	19,324,293	20,708,066

5.2 LOANS & RECEIVABLES (L & R)

Unlisted Debentures	5.2.1	1,367,206	1,364,944	1,890,781	1,886,620
Term Deposits		27,945,441	27,945,441	22,864,910	22,864,910
Development Bonds		2,428,326	2,428,326	5,254,857	5,254,857
Trust Certificates		-	-	37,481	37,481
		31,740,973	31,738,711	30,048,030	30,043,868

As at 31st December	2014				2013			
	Maturity Date	Face Value Rs. '000	Carrying Value Rs. '000	Fair Value Rs. '000	Maturity Date	Face Value Rs. '000	Carrying Value Rs. '000	Fair Value Rs. '000
5.2.1 UNLISTED DEBENTURES								
Commercial Bank of Ceylon PLC	15.05.2016	125,000	141,608	134,834	15.05.2016	125,000	141,608	131,784
People's Leasing & Finance PLC	-	-	-	-	26.04.2014	500,000	515,375	515,375
Lankem Ceylon PLC	08.04.2016	200,000	200,041	200,041	08.04.2016	200,000	200,064	200,064
Singer (Sri Lanka) PLC	30.04.2015	250,000	254,040	254,040	30.04.2015	250,000	255,327	255,327
Central Finance PLC	24.05.2015	500,000	521,138	521,148	24.05.2015	500,000	528,015	528,015
Siyapatha Finance Ltd. (Formerly, Sampath Leasing & Factoring Ltd.)	17.12.2015	50,000	50,336	54,848	17.12.2015	50,000	50,336	55,999
National Development Bank PLC	30.06.2016	200,000	200,043	200,043	30.06.2016	200,000	200,056	200,056
		1,325,000	1,367,206	1,364,944		1,825,000	1,890,781	1,886,620

As at 31st December	Note	2014		2013	
		Carrying Value Rs. '000	Fair Value Rs. '000	Carrying Value Rs. '000	Fair Value Rs. '000
5.3 AVAILABLE-FOR-SALE (AFS) FINANCIAL ASSETS					
Listed Shares	5.3.1	35,711,339	35,711,339	24,798,653	24,798,653
Unlisted Shares	5.3.2	143,257	143,257	124,480	124,480
Unit Trusts	5.3.3	1,146,236	1,146,236	1,426,408	1,426,408
Listed Debentures	5.3.4	11,880,406	11,880,406	7,190,339	7,190,339
Treasury Bills		-	-	483,700	483,700
Treasury Bonds		4,387,187	4,387,187	5,418,642	5,418,642
		53,268,425	53,268,425	39,442,223	39,442,223

As at 31st December	2014			2013		
	No. of Shares	Carrying Value Rs. '000	Fair Value Rs. '000	No. of Shares	Carrying Value Rs. '000	Fair Value Rs. '000
5.3.1 LISTED SHARES						
Banks, Finance and Insurance						
Commercial Bank of Ceylon PLC	75,978,852	12,992,383	12,992,383	74,802,912	9,058,633	9,058,633
DFCC Bank PLC	26,509,832	5,805,653	5,805,653	26,509,832	3,433,023	3,433,023
Seylan Bank PLC	26,396,608	2,507,678	2,507,678	26,396,608	1,713,140	1,713,140
Hatton National Bank PLC	47,635,487	9,288,920	9,288,920	47,635,487	7,002,417	7,002,417
National Development Bank PLC	17,193,914	4,298,479	4,298,479	17,193,914	2,759,623	2,759,623
Sector Total		34,893,113	34,893,113		23,966,836	23,966,836
Construction and Engineering						
Colombo Dock Yard PLC	3,592,998	693,449	693,449	3,592,998	682,670	682,670
Sector Total		693,449	693,449		682,670	682,670
Telecommunications						
Sri Lanka Telecom PLC	2,094,476	105,771	105,771	3,032,200	112,191	112,191
Sector Total		105,771	105,771		112,191	112,191
Manufacturing						
Blue Diamonds Jewellery						
Worldwide PLC	10,559,100	19,006	19,006	10,559,100	36,957	36,957
Sector Total	10,559,100	19,006	19,006		36,957	36,957
Total Investment in Listed Shares		35,711,339	35,711,339		24,798,653	24,798,653

As at 31st December	2014			2013		
	No. of Shares	Carrying Value Rs. '000	Fair Value Rs. '000	No. of Shares	Carrying Value Rs. '000	Fair Value Rs. '000
5.3.2 UNLISTED SHARES						
Associated Newspapers of Ceylon Ltd.	61,206	5,671	5,671	61,206	4,784	4,784
Fitch Ratings Lanka Ltd.	62,500	1,368	1,368	62,500	963	963
Ceybank Asset Management Ltd.	759,998	99,925	99,925	759,998	83,227	83,227
Texpro Industries Ltd.	2,250,000	13,793	13,793	2,250,000	13,005	13,005
National Asset Management Ltd.	1	-	-	1	-	-
VINC Advertising (Pvt) Ltd.	-	-	-	250,000	-	-
Ceylon Asset Management Company Ltd.	1,250,000	22,500	22,500	1,250,000	22,500	22,500
Total Investment in Unlisted Shares		143,257	143,257		124,480	124,480

As at 31st December	2014			2013		
	No. of Shares	Carrying Value Rs. '000	Fair Value Rs. '000	No. of Shares	Carrying Value Rs. '000	Fair Value Rs. '000
5.3.3 UNIT TRUST						
Ceybank Unit Trust	17,000,000	549,100	549,100	33,628,291	867,946	867,946
Ceylon Income Fund	25,000,000	351,250	351,250	27,004,714	356,462	356,462
Comtrust Equity Fund	24,836,957	245,886	245,886	12,016,630	202,000	202,000
		1,146,236	1,146,236		1,426,408	1,426,408

As at 31st December	2014				2013			
	Maturity Date	Face Value Rs. '000	Carrying Value Rs. '000	Fair Value Rs. '000	Maturity Date	Face Value Rs. '000	Carrying Value Rs. '000	Fair Value Rs. '000
5.3.4 LISTED DEBENTURES								
Banks, Finance and Insurance								
Bank of Ceylon	29.11.2017	500,000	507,014	507,014	29.11.2017	500,000	507,014	507,014
Bank of Ceylon	24.10.2018	287,970	294,944	294,944	24.10.2018	287,970	294,944	294,944
Bank of Ceylon	21.09.2019	500,000	510,768	510,768	-	-	-	-
Bank of Ceylon	24.10.2023	67,050	80,381	80,381	24.10.2023	67,050	68,768	68,768
Hatton National Bank PLC	12.06.2018	316,717	341,256	341,256	12.06.2018	316,717	341,256	341,256
Hatton National Bank PLC	14.12.2019	500,000	501,805	501,805	-	-	-	-
Hatton National Bank PLC	31.03.2021	478,459	249,130	249,130	31.03.2021	478,459	224,437	224,437
Hatton National Bank PLC	30.08.2023	126,888	92,435	92,435	30.08.2023	126,888	90,506	90,506
Hatton National Bank PLC	31.03.2024	1,362,794	508,121	508,121	31.03.2024	1,362,794	456,742	456,742
Commercial Bank of Ceylon PLC	18.12.2016	250,000	285,032	285,032	18.12.2016	250,000	285,032	285,032
National Development Bank PLC	19.12.2023	750,000	984,600	984,600	19.12.2013	750,000	753,713	753,713
Seylan Bank PLC	21.02.2018	449,520	473,905	473,905	21.02.2018	449,520	473,905	473,905
Sampath Bank PLC	22.12.2019	500,000	501,060	501,060	-	-	-	-
Sampath Bank PLC	11.10.2017	36,600	45,201	45,201	11.10.2017	36,600	45,201	45,201
Sampath Bank PLC	04.12.2018	340,190	362,484	362,484	04.12.2018	340,190	343,583	343,583
Sampath Bank PLC	14.12.2019	500,000	501,886	501,886	-	-	-	-
Nations Trust Bank PLC	04.08.2016	200,000	209,041	209,041	04.08.2016	200,000	209,041	209,041
DFCC Bank PLC	18.08.2017	64,660	66,656	66,656	-	-	-	-
DFCC Vardhana Bank PLC	07.09.2016	148,148	148,181	148,181	07.09.2016	148,148	148,190	148,190
Pan Asia Banking Corporation PLC	18.03.2017	200,000	205,647	205,647	18.03.2017	200,000	207,784	207,784
The Housing Development Finance Corporation Bank of Sri Lanka	23.10.2018	100,000	122,470	122,470	23.10.2018	100,000	103,970	103,970
Merchant Bank of Sri Lanka PLC	-	-	-	-	15.11.2014	140,000	148,245	148,245
Merchant Bank of Sri Lanka PLC	11.12.2019	113,520	114,892	114,892	-	-	-	-
People's Leasing & Finance PLC	23.09.2017	750,000	767,800	767,800	-	-	-	-
People's Leasing & Finance PLC	26.03.2018	105,900	135,863	135,863	26.03.2018	105,900	123,960	123,960
People's Leasing & Finance PLC	23.09.2018	750,000	769,580	769,580	-	-	-	-
LB Finance PLC	28.11.2018	220,670	236,800	236,800	28.11.2018	220,670	223,563	223,563
Lanka ORIX Leasing Company PLC	30.06.2015	100,000	105,846	105,846	30.06.2015	100,000	105,846	105,846
Senkadagala Finance PLC	10.12.2018	100,000	100,853	100,853	10.12.2018	100,000	100,863	100,863
Citizens Development Business Finance PLC	19.12.2018	37,350	37,556	37,556	19.12.2018	37,350	37,556	37,556
Softlogic Finance PLC*	29.08.2019	12,600	13,061	13,061	-	-	-	-
Sector Total		9,869,036	9,274,268	9,274,268		6,318,256	5,294,118	5,294,118

*Guaranteed by Guaranco Ltd. which is ultimately owned by multilateral G10 Governments.

As at 31st December	2014			2013				
	Maturity Date	Face Value Rs. '000	Carrying Value Rs. '000	Fair Value Rs. '000	Maturity Date	Face Value Rs. '000	Carrying Value Rs. '000	Fair Value Rs. '000
Diversified Holdings								
Hayleys PLC	09.07.2016	80,800	83,702	83,702	09.07.2016	80,800	80,800	80,800
Hemas Holdings PLC	29.04.2019	119,970	125,900	125,900	-	-	-	-
Richard Pieris and Company PLC	16.05.2017	29,580	30,739	30,739	-	-	-	-
Sector Total		230,350	240,341	240,341		80,800	80,800	80,800
Heath Care								
Nawaloka Hospitals PLC	30.09.2021	150,000	155,425	155,425	30.09.2021	150,000	155,484	155,484
Sector Total		150,000	155,425	155,425		150,000	155,484	155,484
Trading								
Abans PLC	20.12.2018	400,000	481,798	481,798	20.12.2018	400,000	401,907	401,907
Singer Sri Lanka PLC	22.12.2017	68,340	68,479	68,479	-	-	-	-
Sector Total		468,340	550,277	550,277		400,000	401,907	401,907
Beverages, Food and Tobacco								
The Lion Brewery Ceylon PLC	17.06.2016	105,600	109,193	109,193	17.06.2016	105,600	109,193	109,193
The Lion Brewery Ceylon PLC	17.06.2017	105,600	109,260	109,260	17.06.2017	105,600	109,260	109,260
The Lion Brewery Ceylon PLC	17.06.2018	140,800	145,769	145,769	17.06.2018	140,800	145,769	145,769
The Lion Brewery Ceylon PLC	08.12.2019	400,000	402,065	402,065	-	-	-	-
Sector Total		752,000	766,287	766,287		352,000	364,222	364,222
Land and Property								
Urban Development Authority*	05.10.2015	871,480	893,808	893,808	05.10.2015	871,480	893,808	893,808
Sector Total		871,480	893,808	893,808		871,480	893,808	893,808
Total Investment in Listed Debentures								
		12,341,206	11,880,406	11,880,406		8,172,536	7,190,339	7,190,339

* Guaranteed by Government Treasury

As at 31st December	Note	2014		2013	
		Carrying Value	Fair Value	Carrying Value	Fair Value
		Rs. '000	Rs. '000	Rs. '000	Rs. '000

5.4 FAIR-VALUE-THROUGH-PROFIT-OR-LOSS (FVTPL) FINANCIAL ASSET

Listed Shares	5.4.1	5,538,347	5,538,347	5,956,726	5,956,726
---------------	-------	-----------	-----------	-----------	-----------

Fair-Value-Through-Profit-or-Loss investments and Available-For-Sale investments have been measured at fair value. Held-To-Maturity investments and Loans and Receivables investments are measured at amortised cost.

As at 31st December	2014			2013		
	No. of Shares	Carrying Value	Fair Value	No. of Shares	Carrying Value	Fair Value
		Rs. '000	Rs. '000		Rs. '000	Rs. '000

5.4.1 LISTED SHARES

Banks, Finance and Insurance

Sampath Bank PLC	287,487	67,559	67,559	387,487	66,609	66,609
Seylan Bank PLC (NV)	-	-	-	359,000	11,057	11,057
Pan Asia Banking Corporation PLC	-	-	-	1,394,666	21,617	21,617
LB Finance PLC	1,842,900	305,921	305,921	1,842,900	188,160	188,160
People's Merchant Finance PLC	1,500	38	38	1,500	17	17
Nations Lanka Finance PLC	979,500	4,800	4,800	979,500	6,954	6,954
Union Bank of Colombo PLC	-	-	-	11,100	184	184
Sector Total		378,318	378,318		294,599	294,599

Beverages, Food and Tobacco

Raigam Wayamba Salterns PLC	-	-	-	1,700,000	3,740	3,740
Sector Total		-	-		3,740	3,740

Diversified Holdings

Hemas Holdings PLC	-	-	-	5,160,700	175,464	175,464
John Keells Holdings PLC	611,176	152,794	152,794	611,176	137,515	137,515
Expo Lanka Holdings PLC	-	-	-	1,071,600	8,037	8,037
Richard Pieris & Company PLC	2,430,000	20,655	20,655	2,430,000	15,309	15,309
Vallibel One PLC	1,121,800	26,923	26,923	1,121,800	18,398	18,398
Softlogic Holdings PLC	-	-	-	15,812,400	132,824	132,824
The Colombo Fort Land & Building PLC	-	-	-	3,020,600	85,181	85,181
Sector Total		200,372	200,372		572,727	572,727

As at 31st December	2014			2013		
	No. of Shares	Carrying Value Rs. '000	Fair Value Rs. '000	No. of Shares	Carrying Value Rs. '000	Fair Value Rs. '000
Footwear and Textiles						
Hayleys MGT Knitting Mills PLC	-	-	-	78,800	875	875
Sector Total	-	-	-		875	875
Hotels and Travels						
Aitken Spence Hotel Holdings PLC	5,518,727	435,979	435,979	7,268,727	543,701	543,701
Asian Hotels & Properties PLC	10,055,900	688,829	688,829	10,055,900	653,634	653,634
John Keells Hotels PLC	71,622,800	1,231,912	1,231,912	72,847,800	910,598	910,598
Anilana Hotels & Properties PLC	2,500,000	20,000	20,000	2,500,000	19,000	19,000
Sector Total		2,376,720	2,376,720		2,126,932	2,126,932
Manufacturing						
Sierra Cables PLC	-	-	-	800	1	1
Lanka Cement PLC	509,700	3,415	3,415	509,700	3,364	3,364
ACL Cables PLC	558,557	42,618	42,618	2,100,200	136,513	136,513
Tokyo Cement Company (Lanka) PLC	-	-	-	3,306,572	94,237	94,237
Tokyo Cement Company (Lanka) PLC (NV)	-	-	-	3,207,320	75,372	75,372
Royal Ceramics PLC	4,083,186	477,733	477,733	4,913,279	422,542	422,542
Lanka Walltiles PLC	807,600	79,064	79,064	807,600	43,287	43,287
Samson International PLC	-	-	-	37	3	3
Sector Total		602,830	602,830		775,321	775,321
Investment Trusts						
Renuka Holdings PLC	1,703,308	53,484	53,484	2,122,698	64,955	64,955
Sector Total		53,484	53,484		64,955	64,955
Motors						
United Motors Lanka PLC	-	-	-	24,200	2,807	2,807
CM Holdings PLC	392,076	50,578	50,578	571,428	48,000	48,000
Diesel & Motor Engineering PLC	-	-	-	315,466	151,739	151,739
Sector Total		50,578	50,578		202,546	202,546
Trading						
Singer Sri Lanka PLC	87,500	10,316	10,316	177,500	15,798	15,798
Brown & Company PLC	906,990	97,048	97,048	906,990	77,094	77,094
TESS Agro PLC	33,993,806	54,390	54,390	35,173,600	45,726	45,726
Sector Total		161,754	161,754		138,617	138,617

As at 31st December	2014			2013		
	No. of Shares	Carrying Value Rs. '000	Fair Value Rs. '000	No. of Shares	Carrying Value Rs. '000	Fair Value Rs. '000
Telecommunications						
Dialog Axiata PLC	-	-	-	12,572,823	113,155	113,155
Sri Lanka Telecom PLC	17,713,735	894,544	894,544	17,713,735	655,408	655,408
Sector Total		894,544	894,544		768,564	768,564
Plantations						
Talawakelle Tea Estates PLC	-	-	-	105,600	2,534	2,534
Sector Total		-	-		2,534	2,534
Power and Energy						
Lanka IOC PLC	-	-	-	271,362	8,955	8,955
Laufgs Gas PLC	7,800	316	316	7,800	222	222
Sector Total		316	316		9,176	9,176
Information Technology						
PC House PLC	876,700	263	263	876,700	526	526
Sector Total		263	263		526	526
Chemicals and Pharmaceuticals						
Lankem Ceylon PLC	313,500	34,485	34,485	516,500	64,046	64,046
CIC Holdings PLC	-	-	-	3,848,894	184,747	184,747
Sector Total		34,485	34,485		248,793	248,793
Land and Property						
Overseas Reality PLC	3,472,300	91,321	91,321	3,472,300	64,238	64,238
Sector Total		91,321	91,321		64,238	64,238
Construction and Engineering						
Colombo Dockyard PLC	3,592,548	693,362	693,362	3,592,548	682,584	682,584
Sector Total		693,362	693,362		682,584	682,584
Total Investment in Listed Shares		5,538,347	5,538,347		5,956,726	5,956,726

5.5 MOVEMENT OF CARRYING VALUES IN FINANCIAL INVESTMENTS

	Available- For-Sale Financial Assets Rs. '000	Fair-Value- Through- Profit-or-Loss Financial Assets Rs. '000	Held-To- Maturity Financial Assets Rs. '000	Loans and Receivables Rs. '000	Total Rs. '000
As at 1st January 2013	38,520,336	10,953,885	15,372,693	23,938,051	88,784,965
Purchases	4,313,538	96,276	9,601,236	47,403,683	61,414,733
Maturities	(6,298,703)		(6,125,000)	(42,298,375)	(54,722,076)
Disposals	-	(4,655,840)	-	-	(4,655,840)
Net Fair Value Gain/(Loss) Recorded in Other Comprehensive Income	2,831,003	-	-	-	2,831,003
Realised Capital Gain/(Loss)	-	-	-	-	-
Realised/Unrealised Capital Gain/(Loss)	-	(437,595)	-	-	(437,595)
Interest Amortisation	163,152	-	431,165	(3,385)	590,930
Foreign Currency Translation Adjustments	-	-	-	(14,723)	(14,723)
Interest/Coupon Receipts	(87,103)	-	44,199	1,022,779	979,875
As at 31st December 2013	39,442,223	5,956,726	19,324,293	30,048,030	94,771,272

	Available- For-Sale Financial Assets Rs. '000	Fair-Value- Through- Profit-or-Loss Financial Assets Rs. '000	Held-To- Maturity Financial Assets Rs. '000	Loans and Receivables Rs. '000	Total Rs. '000
As at 1st January 2014	39,442,223	5,956,726	19,324,293	30,048,030	94,771,272
Purchases	4,557,040	-	6,855,132	47,698,666	59,110,838
Maturities	(1,840,000)	-	(900,001)	(45,292,297)	(48,032,298)
Disposals	(824,368)	(1,842,007)	-	-	(2,666,375)
Fair Value Gain Recorded in Other Comprehensive Income	11,160,541	-	-	-	11,160,541
Realised Capital Gain/(Loss)	407,842	-	-	-	407,842
Realised/Unrealised Capital Gain/(Loss)	-	1,423,628	-	-	1,423,628
Interest Amortisation	167,207	-	472,836	(13,481)	626,562
Foreign Currency Translation Adjustments	-	-	-	(170,776)	(170,776)
Interest Income	1,536,342	-	2,405,388	3,141,767	7,083,497
Interest/Coupon Receipts	(1,338,401)	-	(2,080,781)	(3,670,933)	(7,090,115)
As at 31st December 2014	53,268,426	5,538,347	26,076,867	31,740,973	116,624,612
			Note	2014 Rs. '000	2013 Rs. '000

6. INVESTMENT IN SUBSIDIARIES

At cost

Listed Subsidiaries	6.1	2,925,567	2,925,567
Unlisted Subsidiaries	6.2	18,160,338	14,660,337
		21,085,905	17,585,904

As at 31st December		2014				2013			
Note	No. of Shares	Holding %	Cost Rs. '000	Fair Value Rs. '000	No. of Shares	Holding %	Cost Rs. '000	Fair Value Rs. '000	
6.1 LISTED SUBSIDIARIES									
The Lanka Hospitals Corporation PLC	122,177,993	54.61	2,925,567	5,864,544	122,177,993	54.61	2,925,567	4,948,209	
			2,925,567	5,864,544			2,925,567	4,948,209	

As at 31st December		2014				2013		
Note	No. of Shares	Holding %	Cost Rs. '000	Fair Value Rs. '000	No. of Shares	Holding %	Cost Rs. '000	
6.2 UNLISTED SUBSIDIARIES								
Litro Gas Lanka Ltd.			35,976,853	99.94	3,510,063	35,976,853	99.94	3,510,063
Litro Gas Terminal Lanka (Pvt) Ltd.			158,710,945	100.00	5,280,188	158,710,945	100.00	5,280,188
Management Services Rakshana (Pvt) Ltd.	6.2.1		5	100.00	-	5	100.00	-
Canwill Holdings (Pvt) Ltd.	6.2.2		850,000,000	45.95	8,500,000	500,000,000	41.67	5,000,000
Canowin Hotels and Spas (Pvt) Ltd.			87,008,686	100.00	870,087	87,008,686	100.00	870,087
					18,160,338			14,660,337

Unlisted shares have been tested for impairment and these were no impairment required for the year.

6.2.1 Management Services Rakshana (Pvt) Ltd. is a wholly-owned subsidiary of Sri Lanka Insurance Corporation Ltd., with a stated capital of Rs. 50/-.

6.2.2 During the year Canwill Holdings (Pvt) Ltd. has made a share issue of 650,000,000. The Company has subscribe for 350,000,000 shares and Litro Gas Lanka Ltd. has subscribed for the balance 300,000,000 shares.

As at 31st December		2014			2013		
	Note	No. of Shares	Effective Holding %	Cost Rs. '000	No. of Shares	Effective Holding %	Cost Rs. '000
6.3 INVESTMENT IN SUB-SUBSIDIARIES							
Sinolanka Hotels & Spa (Pvt) Ltd.	6.3.1	1,450,000,000	73.0	14,500,000	1,200,000,000	58.3	12,000,000
Lanka Hospitals Diagnostics (Pvt) Ltd.	6.3.2	3,500,020	54.6	350,000	5,000,002	54.6	50,000,020
Helanco Hotels & Spa (Pvt) Ltd.	6.3.3	400,000,000	73.0	4,000,000	-	-	-
				368,500,020			62,000,020

6.3.1 During the year Sinolanka Hotels & Spa (Pvt) Ltd. has made a share issue of 250,000,000 and Canwill Holdings (Pvt) Ltd. has fully subscribed the share issue.

6.3.2 During the year Lanka Hospitals Diagnostics (Pvt) Ltd. has made a share issue of 30,000,000 and The Lanka Hospitals Corporation PLC has fully subscribed the share issue.

6.3.3 During the year Helanco Hotels & Spa (Pvt) Ltd. has made a share issue of 400,000,000 and Canwill Holdings (Pvt) Ltd. has subscribed the entire share issue.

As at 31st December	2014 Rs. '000	2013 Rs. '000
---------------------	------------------	------------------

7. PROPERTY, PLANT & EQUIPMENT

7.1 CONSOLIDATED

Carrying Amount	24,525,873	23,396,579
Work-in-Progress (Note 7.1.1)	11,057,326	7,416,316
	35,583,199	30,812,895

	Land	Buildings on Freehold Land	Building on Leasehold Land	Equipment	Furniture & Fittings	Motor Vehicle
	Rs. '000	Rs. '000	Rs. '000	Rs. '000	Rs. '000	Rs. '000
Cost/Valuation						
Freehold						
Balance as at 1st January 2014	5,297,628	3,107,030	3,501,748	3,083,148	471,694	791,761
Additions During the Year	-	39,811	81,482	547,134	99,929	149,718
Revaluation	427,524	(40,511)	(1,646)	-	-	-
Disposals	(13,838)	(49,520)	-	(87,471)	(32)	(74,687)
Balance as at 31st December 2014	5,711,314	3,056,810	3,581,584	3,542,811	571,591	866,792
Accumulated Depreciation						
Freehold						
Balance as at 1st January 2014	-	149,232	21,141	1,655,904	211,117	236,535
Depreciation Charge for the Year	-	147,705	98,831	212,417	40,791	199,497
Revaluation	-	(276,082)	(4,376)	-	-	-
Disposal	-	(1,649)	-	(79,286)	(32)	(35,168)
Balance as at 31st December 2014	-	19,206	115,596	1,789,035	251,876	400,864
Net Book Value						
As at 31st December 2013	5,297,628	2,957,798	3,480,607	1,427,244	260,577	555,226
As at 31st December 2014	5,711,314	3,037,604	3,465,988	1,753,776	319,715	465,928

THE LANKA HOSPITALS CORPORATION PLC

The freehold lands of The Lanka Hospitals Corporation PLC were revalued as at 31st December 2014 by an independent professionally qualified valuer and a revaluation surplus of Rs. 42,226,851/- was incorporated in the Financial Statements as at 31st December 2014. The revaluation was based on the market approach basis (direct comparison method) and cost approach basis. The surplus arising from the revaluation was transferred to the 'revaluation reserve' in shareholders equity and the value of the freehold land of the Company was reflected in the Financial Statements at the revalued amount.

A revaluation of the buildings was performed by an independent professionally qualified valuer as at 31st December 2013. The revaluation was based on the market approach basis (direct comparison method) and cost approach basis. The revaluation surplus net of applicable deferred income taxes was credited to other comprehensive income and is shown in 'revaluation reserve' in shareholders equity.

Electrical Generators	Fixtures & Fittings	Air- Condition Plant	Plant & Machinery	Storage Tanks, Pipe Lines and Pumping Stations	LPG Cylinders	Others	Total
Rs. '000	Rs. '000	Rs. '000	Rs. '000	Rs. '000	Rs. '000	Rs. '000	Rs. '000
81,315	258,832	201,657	1,195,112	5,251,237	4,003,800	143,479	27,388,441
22,540	52	1,863	59,441	36,619	924,972	57,553	2,021,114
49,000	-	-	-	-	-	-	434,367
-	-	-	-	-	(2,929)	(190)	(228,667)
152,855	258,884	203,520	1,229,764	5,283,131	4,925,733	200,842	29,585,631
15,931	46,653	19,674	100,239	554,407	897,008	84,021	3,991,862
9,119	37,377	20,208	58,019	212,391	438,712	19,650	1,494,717
-	-	-	-	-	-	-	(280,458)
-	-	-	-	-	(1,166)	(12)	(117,313)
25,050	84,030	39,882	133,758	762,248	1,334,554	103,659	5,059,758
65,384	212,179	181,983	1,094,873	4,696,830	3,106,792	59,458	23,396,579
127,805	174,854	163,638	1,096,006	4,520,883	3,591,179	97,183	24,525,873

If The Lanka Hospitals Corporation PLC has included its revalued assets at cost less depreciation in its Financial Statements, the carrying value would be as follows:

7.1.A FREEHOLD LANDS

Location	Extent (Perches)	Cost of Land Rs. '000
Narahenpita		
Hathbodiya, Kirula Road, Narahenpita, Colombo 05	10.25	7,461
Hathbodiya, Kirula Road, Narahenpita, Colombo 05	10	5,257

7.1.B. BUILDINGS ON LEASEHOLD LAND

	Cost Rs. '000	Accumulated Depreciation Rs. '000	Net Book Value Rs. '000
Building on Leasehold Land	1,489,295	383,474	1,105,821

7.1.C DEPRECIATION

SRI LANKA INSURANCE CORPORATION LTD.

Property, Plant & Equipment includes fully-depreciated assets having a gross carrying amount of Rs. 286.5 million (2013 - Rs. 286.5 million).

THE LANKA HOSPITALS CORPORATION PLC

Depreciation expense of Rs. 90,292,205/- (2013 - Rs. 92,537,707/-) has been charged under 'cost of service' and Rs. 151,596,755/- (2013 - 127,957,387/-) under depreciation on Property, Plant & Equipment in the statement of comprehensive income.

7.1.D LEASEHOLD LAND

SINOLANKA HOTELS & SPA (PVT) LTD.

Sinolanka Hotels & Spa (Pvt) Ltd. has entered into an agreement dated 16th July 2012 with the Urban Development Authority (hereafter referred to as the 'Lessor'), whereby Lessor allocated to the Company (hereafter referred to as the 'Lessee') a block of land bearing assessment No. 116, Galle Road, Colombo 03 comprising in extent 0.6057 hectares together with the partly constructed building thereon, for an annual nominal lease of Rs. 10,000/- for a term of period of 99 years for the purpose of constructing and operating a luxury hotel complex. The agreement further provided that the settlement of nominal annual lease for the period of 99 years in one lump sum of Rs. 990,000/- which was made during the period under review.

Upon the termination of the lease by effluxion of time, the Lessor may grant to the Lessee or its successors a renewal of the lease for a further period of 99 years or for a period to be mutually agreed upon by the Lessor

and Lessee. In the event of termination or de-termination of the lease at the expiration of the said term as the case may be and on Lessee yielding the demised premises with all buildings and with all furniture and fixtures and everything standing thereon to the Lessor, the Lessor shall purchase the building and everything standing thereon at the market value prevailing at the time.

In addition to the aforesaid lease agreement, the Government Valuation Department determined a value of Rs. 5.0 billion to be paid by the Company as full and final consideration to the Secretary to the Treasury in respect of the said property situated at No. 116, Galle Road, Colombo 03. The Government Valuation Department further determined that the value attributable to the land in extent of 0.6057 hectares based on a 99 year lease for the purpose of constructing and operating a luxury hotel complex amounted to Rs. 1.228 billion. The balance value is arranged to the immovable properties constructed on the said lease land.

7.1.E FREEHOLD LAND

SINOLANKA HOTELS & SPA (PVT) LTD.

The Sinolanka Hotels & Spa (Pvt) Ltd. has purchased three blocks of land with buildings attached to land, with the intention of demolishing the buildings in 2014 to facilitate the expansion of ballroom, car parking facilities, reorganisation of traffic circulation and compliance with the regulatory requirement. The total cost of the said land and buildings purchased during the year is Rs. 1,139,357,179.30. The cost, of the buildings attached to the three blocks of land purchased with the intention of building a car park facilities expansion of ballroom and reorganisation of traffic circulation have been allocated to the hotel building under the capital work-in-progress since those facilities are not capable of generating independent cash flows from continued use. The cost of the freehold land is determined based on the valuation determined by the Government Valuation Department which is Rs. 7 million per perch. The land extend of three blocks of land are Assessment No. 112 - 62.77 perches, Assessment No. 108 - 15 perches and Assessment No. 134 - 20.10 perches. The total additions to the freehold land above include the direct cost related to the acquisition.

7.1.1 CAPITAL WORK-IN-PROGRESS

As at 31st December	Consolidated		Company	
	2014 Rs. '000	2013 Rs. '000	2014 Rs. '000	2013 Rs. '000
At the Beginning of the Year	7,416,316	4,764,889	-	-
Cost Incurred during the Year	4,854,438	4,216,485	-	-
Amount Capitalised during the Year	(1,213,428)	(1,565,058)	-	-
At End of the Year	11,057,326	7,416,316	-	-

The capital-work-in-progress consist of the partly completed property at No. 116, Galle Road, Colombo 03, Hyatt Regency Colombo Hotel which amounts to Rs. 10,739,969,000/-.

7.1.2 ASSETS REVALUATION

SRI LANKA INSURANCE CORPORATION LTD. - COMPANY

Sri Lanka Insurance Corporation Ltd. has revalued its land and buildings as at 31st December 2014 by Messrs Sunil Fernando Associates (Pvt) Ltd. Chartered Valuation Surveyor. Assets were valued using cost approach basis. The surplus arising from the revaluation was transferred to the revaluation reserve. SLIC value of the lands and buildings are stated below:

Location	Extend of the Land	Land Rs. '000	Building Rs. '000	Total Rs. '000	Carrying Amount at Cost Rs. '000
Land situated at No. 288, Union Place, Colombo 2	A 01 R 00 P 20.35	1,352,625	32,460	1,385,085	5,283
Land & Building situated at No. 267, Union Place, Colombo 2	A 0 R 0 P 37.62	263,340	420,889	684,229	6,151
Land & Building situated at No. 21, Vauxhall Street, Colombo 2	A 02 R 00 P 05.62	1,850,750	1,878,648	3,729,398	106,982
Land & Building situated at Thelawala, Katubedda, Moratuwa	A 02 R 00 P 13	149,850	50,433	200,283	2,487
Land & Building situated at Lake Road, 4th Lane, Anuradhapura	A 0 R 0 P 30	6,750	4,623	11,373	311
Land & Building situated at Main Street, 2nd Lane, Anuradhapura	A 0 R 0 P 34.9	61,075	8,177	69,252	780
Land & Building situated at 571, Hospital Road, Jaffna	A 0 R 1 P 26.38	106,208	22,950	129,158	656
Land & Building situated at No. 25, Kande Veediya, Kandy	A 0 R 0 P 16.45	102,812	33,172	135,984	21,961
Land & Building situated at No. 20, Rajapaksha Broadway, Negombo	A 0 R 0 P 19	47,500	28,155	75,655	2,136
Land & Building situated at No. 7, Hakmana Road, Matara	A 0 R 0 P 47.89	131,697	26,465	158,162	1,388
Land & Building situated at No. 60/1, Park Road, Nuwara Eliya	A 0 R 02 P 23.01	113,311	4,158	117,469	755
Building situated at No. 16/1, Dambulla Road, Kurunegala	-	-	61,689	61,689	3,075
Land & Building situated at No. 14A, Pulathisigama, Hingurakgoda	A 0 R 0 P 49.42	3,459	1,183	4,643	320
Land & Building situated at No. 46, Main Street, Trincomalee	A 0 R 01 P 37.65	77,650	10,951	88,601	2,068
Land & Building situated at No. 77, Ratnapura Road, Awissawella	A 0 R 0 P 30.75	84,562	3,727	88,290	2,201
Land situated at Buddhaloka Mawatha, Gampaha	A 0 R 0 P 24.54	67,485	-	67,485	3,758

Location	Extend of the Land	Land Rs. '000	Building Rs. '000	Total Rs. '000	Carrying Amount at Cost Rs. '000
Land & Building situated at No. 14, River Side Road, Kalutara	A 0 R 0 P 61.9	29,402	-	29,402	3,551
Land & Building situated at No. 32, Negombo Road, Marawila	A 0 R 0 P 10	8,000	3,918	11,918	1,926
Land & Building situated at No. 195, Bowela Village, Heerassagala, Kandy	A 0 R 01 P 02	10,500	5,352	15,852	3,666
Land & Building situated at No. 97, New Road, Ambalangoda	A 0 R 01 P 02	94,500	35,865	130,365	2,341
Land & Building situated at No. 211/C, Colombo Road, Pilimatalawa	A 0 R 0 P 08	20,000	12,568	32,568	20,799
Land situated at No. 42, Kurunegala Road, Chilaw	A 0 R 0 P 15.63	31,260	-	31,260	2,611
Land & Building situated at No. 38, Miyugunagama, Mahiyanganaya	A 0 R 0 P 09.96	4,980	520	5,500	228
Land & Building situated at Bogahahena, Dikwella Road, Beliatta	A 0 R 01 P 27.13	35,243	-	35,243	27,907
Land & Building situated at No. 68, Ragala Road, Rikillagaskada	A 0 R 0 P 6.832	17,080	5,942	23,022	18,880
Land situated at Gorakadeniya, Yatinuwara, Kandy	A 0 R 02 P 40.17	26,729	-	26,729	15,599
Land & Building situated at No. 69, Kothmale Road, Nawalapitiya	A 0 R 0 P 05	11,250	10,269	21,519	14,376
Land situated at No. 157, Thangalle Road, Thawaluwila, Ambalantota	A 0.0817 R 0 P 32.33	5,250	-	5,250	-
Land & Building situated at No. 6, Wadugodapitiya Veediya, Kandy	A 0 R 0 P 08.50	31,875	15,273	47,148	17,350
Land & Building situated at No. 389, Main Street, Kegalle	A 0 R 0 P 09.51	20,652	-	20,652	16,119
Land situated at Kachchery Junction, Kandy Road, Jaffna	A 0 R 0 P 36.67	9,400	-	9,400	275
		4,775,198	2,677,393	7,452,592	305,949

As at 31st December	2014	2013
	Rs. '000	Rs. '000

7.2 COMPANY

Carrying Amount	8,585,240	8,265,863
	8,585,240	8,265,863

	Land	Buildings on Freehold Land	Building on Leasehold Land	Equipment	Furniture & Fittings	Motor Vehicle
	Rs. '000	Rs. '000	Rs. '000	Rs. '000	Rs. '000	Rs. '000
Cost/Valuation						
Balance as at 1st January 2014	4,428,965	2,773,010	10,426	560,464	227,113	358,693
Additions during the Year	-	-	-	46,182	23,194	55,416
Revaluation	360,072	(46,097)	(1,648)	-	-	-
Disposals/Transfers	(13,838)	(49,520)	-	-	-	(54,400)
Balance as at 31st December 2014	4,775,199	2,677,393	8,778	606,646	250,307	359,709
Accumulated Depreciation						
Balance as at 1st January 2014	-	138,650	3,012	273,363	67,296	83,634
Depreciation Charge for the Year	-	139,080	1,364	62,031	18,312	94,324
Revaluation	-	(276,082)	(4,376)	-	-	-
Disposal	-	(1,648)	-	-	-	(27,000)
Balance as at 31st December 2014	-	-	-	335,394	85,608	150,958
Carrying Amount						
As at 31st December 2013	4,428,965	2,634,360	7,414	287,101	159,817	275,059
As at 31st December 2014	4,775,199	2,677,393	8,778	271,252	164,699	208,751

During the year Company has acquired Property, Plant & Equipment amounting to Rs. 152.696 million (2013 – Rs. 190.804 million).

Property, Plant & Equipment includes fully-depreciated assets having a gross carrying amount of Rs. 286.5 million (2013 – Rs. 286.5 million).

There were no assets pledged against the borrowings as at the reporting date.

On reassessment of the fair value of the Company's assets, it has been identified that there is no permanent impairment of Property, Plant & Equipment which requires provision in the Financial Statements other than those already written-off.

Electrical Generators and Passenger Lift Rs. '000	Fixtures & Fittings Rs. '000	Air- Condition Plant Rs. '000	Others Rs. '000	Total 2014 Rs. '000
81,314	258,832	201,658	16,317	8,916,792
22,541	52	1,863	3,448	152,696
49,000	-	-	-	361,327
-	-	-	-	(117,758)
152,855	258,884	203,521	19,765	9,313,057
15,931	46,653	19,673	2,717	650,929
9,118	37,377	20,208	4,180	385,994
-	-	-	-	(280,458)
-	-	-	-	(28,648)
25,049	84,030	39,881	6,897	727,817
65,383	212,179	181,985	13,600	8,265,863
127,806	174,854	163,640	12,868	8,585,240

As at 31st December	Consolidated		Company	
	2014 Rs. '000	2013 Rs. '000	2014 Rs. '000	2013 Rs. '000
8. INVESTMENT PROPERTY				
Balance as at 1st January	1,333,645	1,325,154	549,600	549,600
Transfer from Property, Plant & Equipment	-	8,491	-	-
Additions during the Year	2,544	-	-	-
Transferred from Leasehold Property	21,680	-	-	-
Fair Value Gains/(Loss)	(154,438)	-	(84,369)	-
Balance as at 31st December	1,203,431	1,333,645	465,231	549,600

Investment property held by Sri Lanka Insurance Corporation Ltd. is located at No. 6, Sir Baron Jayathilake Mawatha, Colombo 1. Extent of land is A0 R0 P38.88 and the extent of the building is 40,000 Sq.Ft.

The investment property held by Canowin Hotels and Spas (Pvt) Ltd. (a subsidiary), is situated at Southern Expressway, Welipenna was revalued as at 31st December 2014 by an external, independent property valuer, Messrs Sunil Fernando Associates (Pvt) Ltd.

As at 31st December	Consolidated		Company	
	2014 Rs. '000	2013 Rs. '000	2014 Rs. '000	2013 Rs. '000
9. LEASEHOLD PROPERTY				
Leasehold Right to Land (Note 9.1)	192,545	21,075	20,806	21,075
Advance Lease Premium (Note 9.2)	164,458	169,398	-	-
Balance as at 31st December	357,003	190,473	20,806	21,075

The SLIC obtained leasehold rights to lands situated in Puttalam, Ratnapura, Paradise Island - Bentota, Nuwara-Eliya, Batticaloa for 99 years from Government of Sri Lanka. The leasehold right is amortised over '99' years.

As at 31st December	Consolidated		Company	
	2014 Rs. '000	2013 Rs. '000	2014 Rs. '000	2013 Rs. '000
9.1 LEASEHOLD RIGHT TO LAND				
Cost				
Balance as at 1st January	28,015	28,015	28,015	28,015
Additions during the year	172,318	-	-	-
Balance as at 31st December	200,333	28,015	28,015	28,015
Amortisation				
Balance as at 1st January	6,940	6,671	6,940	6,671
Amortisation of Leasehold Land	848	269	269	269
Balance as at 31st December	7,788	6,940	7,209	6,940
Net balance as at 31st December	192,545	21,075	20,806	21,075

HELANCO HOTELS & SPA (PVT) LTD.

Helanco Hotels & Spa (Pvt) Ltd. entered into an agreement dated 1st September 2014 with the Urban Development Authority ("UDA"), whereby UDA allocated to the Company a block of land situated at Lewaya Road, Hambanthota, comprising in extent 3.812 hectares, for a sum of Rs. 149,601,875/- for a term period of 99 years, for the purpose of constructing and operating a Luxury Hotel Complex. The agreement further provided that the settlement of annual lease for the period of 99 years in one lump sum of Rs. 4,950,000/- which was made during the period under review.

As at 31st December	Consolidated		Company	
	2014 Rs. '000	2013 Rs. '000	2014 Rs. '000	2013 Rs. '000
9.2 ADVANCED LEASE PREMIUM				
Balance at the beginning of the Period	169,398	155,758	-	-
Premium Paid during the Period	21,506	18,547	-	-
Amortised during the Period	(4,766)	(4,907)	-	-
Transferred to Investment Property	(21,680)	-	-	-
Balance at the end of the Period	164,458	169,398	-	-

Canowin Hotels and Spas (Pvt) Ltd. (a subsidiary), has a leasehold property located on Southern Expressway, Welipenna, which has been leased from the Road Development Authority for a period of 99 years starting from 19th August 2011.

The Lanka Hospitals Corporation PLC a subsidiary of SLIC, has entered into a 99-year lease agreement with the Urban Development Authority from 1999. In terms of this agreement, a further sum of Rs. 268.92 million is payable by 2026. Lease rent on each installment is carried forward and amortised over the 99-year period, in accordance with the said agreement.

As at 31st December	Consolidated		Company	
	2014 Rs. '000	2013 Rs. '000	2014 Rs. '000	2013 Rs. '000
10. INTANGIBLE ASSETS				
Goodwill on Acquisition (Note 10.1)	2,992,805	2,992,805	-	-
Computer Software (Note 10.2)	173,966	126,798	141,336	120,041
	3,166,771	3,119,603	141,336	120,041

As at 31st December	Consolidated		Company	
	2014 Rs. '000	2013 Rs. '000	2014 Rs. '000	2013 Rs. '000

10.1 GOODWILL ON ACQUISITION

Cost

Balance as at 1st January	2,992,805	2,992,805	-	-
Balance as at 31st December	2,992,805	2,992,805	-	-

The aggregated carrying amount of goodwill allocated to each unit is as follows:

	2014 Rs. million	2013 Rs. million	2014 Rs. million	2013 Rs. million
The Lanka Hospitals Corporation PLC	1,577	1,577	-	-
Litro Gas Lanka Ltd.	842	842	-	-
Litro Gas Terminal Lanka (Pvt) Ltd.	574	574	-	-
	2,993	2,993	-	-

There has been no permanent impairment of intangible assets that requires a provision. Methods used in estimating recoverable amounts are given below:

The recoverable amount of goodwill related to acquisition of The Lanka Hospitals Corporation PLC, Litro Gas Lanka Ltd. and Litro Gas Terminal Lanka (Pvt) Ltd. was determined based on value in use.

Business growth based on historical growth rate and business plan:

Current inflation rate as per CBSL

Discount rate – Average market borrowing rate adjusted for risk premium

Margin – Based on current margins and business plan

As at 31st December	Consolidated		Company	
	2014 Rs. '000	2013 Rs. '000	2014 Rs. '000	2013 Rs. '000

10.2 COMPUTER SOFTWARE

Cost

Balance as at 1st January	182,901	171,318	175,444	170,104
Additions	93,981	11,583	64,766	5,340
Balance as at 31st December	276,882	182,901	240,210	175,444

Amortisation

Balance as at 1st January	56,104	21,433	55,403	21,382
Amortisation Charge	46,812	34,671	43,471	34,021
Balance as at 31st December	102,916	56,104	98,874	55,403
	173,966	126,798	141,336	120,041

As at 31st December	Consolidated		Company	
	2014 Rs. '000	2013 Rs. '000	2014 Rs. '000	2013 Rs. '000

11. LOANS TO POLICYHOLDERS

Policyholder Loans

Balance as at 1st January	1,578,196	1,559,451	1,578,196	1,559,451
Loans Granted during the Year	506,943	625,011	506,943	625,011
Interest Receivable on Loans	253,263	221,796	253,263	221,796
Loans Settled during Year (Against Claims)	(828,336)	(828,063)	(828,336)	(828,063)
Balance as at 31st December	1,510,067	1,578,196	1,510,067	1,578,196

The surrender value of the loans granted to policyholders as at 31st December 2014 amounted to Rs. 2,809 million (2013 - Rs. 2,955 million).

The Company grants policy loans at the market rate and hence initial recognition is at fair value.

If the total receivable of the loan including interest due and accrued exceeds the surrender value the policy terminates and becomes void. The Company has the first lien on all policies which are subject to policy loans and this mitigates the Company's credit exposure on Policy Loans.

The Board of Directors has assessed the potential impairment loss of loans where total receivable exceeds the surrender value and charged (reversed) in the Financial Statements as at the reporting date in respect of loans to Life Policyholders.

The carrying value of policyholder's loan approximate to the Fair Value at the reporting date.

As at 31st December	Consolidated		Company	
	2014 Rs. '000	2013 Rs. '000	2014 Rs. '000	2013 Rs. '000

12. REINSURANCE RECEIVABLE

Reinsurance Receivables on Settled Claims	225,175	286,043	225,175	286,043
Reinsurance Receivables on Outstanding Claims	1,003,992	1,160,449	1,003,992	1,160,449
	1,229,167	1,446,491	1,229,167	1,446,491
Impairment on Reinsurance Receivables	(22,322)	(249)	(22,322)	(249)
	1,206,845	1,446,243	1,206,845	1,446,243

IMPAIRMENT OF REINSURANCE RECEIVABLES

The Board of Directors has assessed the potential impairment loss of reinsurance receivables and provide the Rs. 22.322 million to Financial Statements as at the reporting date in respect to the reinsurance receivable.

The Carrying value of reinsurance receivables approximate the fair value at the reporting date.

As at 31st December	Consolidated		Company	
	2014 Rs. '000	2013 Rs. '000	2014 Rs. '000	2013 Rs. '000
13. PREMIUM RECEIVABLE				
13.1 PREMIUM RECEIVABLE FROM POLICYHOLDERS				
Premium Receivable from Policyholders	2,429,106	2,381,614	2,429,106	2,381,614
	2,429,106	2,381,614	2,429,106	2,381,614
Impairment on Premium Receivable				
As at the Beginning of the Year	(27,070)	(65,670)	(27,070)	(65,670)
Impairment Reversal Made during the Year	(190,758)	38,600	(190,758)	38,600
As at the end of the Year	(217,828)	(27,070)	(217,828)	(27,070)
Sub Total of Premium Receivable from Policyholders	2,211,278	2,354,544	2,211,278	2,354,544
13.2 PREMIUM RECEIVABLE FROM AGENTS, BROKERS AND INTERMEDIARIES				
Premium Receivable from Agents and Brokers	719,633	684,620	719,633	684,620
	719,633	684,620	719,633	684,620
Impairment on Premium Receivable				
As at the Beginning of the Year	(9,023)	(21,890)	(9,023)	(21,890)
Impairment Reversal Made during the Year	(63,586)	12,867	(63,586)	12,867
As at the End of the Year	(72,609)	(9,023)	(72,609)	(9,023)
Sub Total of Premium Receivable from Agents and Brokers	647,024	675,597	647,024	675,597
Total Premium Receivable	2,858,302	3,030,141	2,858,302	3,030,141

The Board of Directors has assessed the potential impairment loss on premium receivables as at the reporting date and adequate provisions have been made in the Financial Statements.

As at 31st December	Consolidated		Company	
	2014 Rs. '000	2013 Rs. '000	2014 Rs. '000	2013 Rs. '000
14. DEFERRED TAX ASSETS				
<i>Deferred Tax Liability</i>				
Capital Allowance for Tax Purpose	(5,906)	(5,586)	(5,841)	(5,548)
Revaluation Deficit of Building	2,965	-	2,965	-
	(2,941)	(5,586)	(2,876)	(5,548)
<i>Deferred Tax Assets</i>				
Defined Benefits Obligations	89,954	62,461	89,505	62,017
Net Deferred Tax Assets	87,013	56,876	86,629	56,469
<hr/>				
	Consolidated		Company	
	2014 Rs. '000	2013 Rs. '000	2014 Rs. '000	2013 Rs. '000
Balance as at 1st January	56,876	48,116	56,469	47,960
Origination/(reversal) of Temporary Difference - Recognised in Profit or Loss	30,137	8,760	30,160	8,509
Balance as at 31st December	87,013	56,876	86,629	56,469

As at 31st December	Consolidated		Company	
	2014 Rs. '000	2013 Rs. '000	2014 Rs. '000	2013 Rs. '000
15. OTHER ASSETS				
Inventories (Note 15.1)	2,022,736	2,386,054	102,052	172,685
Other Receivables	2,452,937	1,764,949	2,471,043	1,665,776
Impairment on Other Receivables	(124,386)	(125,902)	(124,386)	(125,902)
	2,328,551	1,639,047	2,346,657	1,539,874
Amount due from Distilleries Company of Sri Lanka PLC and Related Companies	149,665.00	132,635	149,665	132,635
Staff Loans (Note 15.2)	564,406	563,578	564,406	563,578
Prepaid Staff Cost	159,759	221,383	159,759	221,383
Other Loans	208,985	171,415	208,985	171,415
Advance on Fixed Assets	45,584	58,807	45,584	58,807
Trade and Other Receivables (Note 15.3)	1,181,175	1,177,102	-	-
ESC Receivable	23,512	28,008	-	-
	6,684,373	6,378,029	3,577,108	2,860,377
15.1 INVENTORIES				
Insurance	102,052	172,685	102,052	172,685
Healthcare	306,301	175,976	-	-
Energy	1,614,383	2,037,394	-	-
	2,022,736	2,386,054	102,052	172,685
15.2 STAFF LOANS				
At the Beginning of the Year	563,578	474,448	563,578	474,448
Loans Granted during the Year	147,283	246,629	147,283	246,629
Recoveries during the Year	(180,409)	(169,899)	(180,409)	(169,899)
Fair Value Adjustment on Staff Loan	33,954	12,400	33,954	12,400
At the End of the Year	564,406	563,578	564,406	563,578

As at 31st December	Consolidated		Company	
	2014 Rs. '000	2013 Rs. '000	2014 Rs. '000	2013 Rs. '000

15.3 TRADE AND OTHER RECEIVABLES

Trade Receivables

Trade and Other Receivables	666,428	460,310	-	-
Provision for Doubtful Debt	(17,284)	(9,951)	-	-
Total Trade Receivables - Net	649,144	450,359	-	-
Deposit and Prepayments	335,183	214,930	-	-
Advances and Other Receivables	196,848	511,812	-	-
	1,181,175	1,177,101	-	-

As at 31st December	Consolidated		Company	
	2014 Rs. '000	2013 Rs. '000	2014 Rs. '000	2013 Rs. '000

16. DEFERRED EXPENSES - INSURANCE CONTRACT

Reserve for Deferred Acquisition Expenses - Net of Reinsurance

Reserve for Deferred Acquisition Expenses

Balance as at 1st January	384,242	374,148	384,242	374,148
Increase in Deferred Acquisition Expenses	9,704	10,094	9,704	10,094
Balance as at 31st December	393,946	384,242	393,946	384,242

Reserve for Deferred Reinsurance Commission

Balance as at 1st January	(137,346)	(152,712)	(137,346)	(152,712)
Increase in Deferred Acquisition Expenses	5,260	15,366	5,260	15,366
Balance as at 31st December	(132,086)	(137,346)	(132,086)	(137,346)

Reserve for Deferred Acquisition Expenses - Net of Reinsurance

	261,860	246,895	261,860	246,895
--	---------	---------	---------	---------

As at 31st December	Consolidated		Company	
	2014 Rs. '000	2013 Rs. '000	2014 Rs. '000	2013 Rs. '000

17. CASH AND CASH EQUIVALENTS

Cash in Hand and at Bank	901,895	767,825	637,799	493,965
Short-Term Investments	24,637,543	28,490,167	5,130,628	12,530,569
Total Cash and Cash Equivalents	25,539,438	29,257,992	5,768,427	13,024,534

As at 31st December	Consolidated		Company	
	2014 Rs. '000	2013 Rs. '000	2014 Rs. '000	2013 Rs. '000

18. STATED CAPITAL

Issued and Fully Paid

Ordinary Shares (599,743,200 Shares)	6,000,000	6,000,000	6,000,000	6,000,000
	6,000,000	6,000,000	6,000,000	6,000,000

18.1 RIGHT OF ORDINARY SHAREHOLDERS

The holders of ordinary shares are entitled to receive dividends as declared from time to time and are entitled to one vote per share at meetings of the Company.

As at 31st December	Note	Consolidated		Company	
		2014 Rs. '000	2013 Rs. '000	2014 Rs. '000	2013 Rs. '000

19. REVALUATION RESERVE

Revaluation Reserve	19.1	9,325,393	8,752,045	5,971,570	5,411,866
		9,325,393	8,752,045	5,971,570	5,411,866

19.1 RESERVE FOR REVALUATION OF LAND AND BUILDING

Balance as at 1st January		8,752,045	9,161,368	5,411,866	5,632,161
Surplus on Revaluation of Land and Building		650,495	102,325	592,783	-
Deferred Tax on Revaluation Surplus		(5,545)	(291,353)	(3,778)	-
Realisation of Revaluation Surplus		(71,602)	(30,320)	(29,301)	(30,320)
Transfer of Fair Value Gain on Investment Property		-	(189,975)	-	(189,975)
Balance as at 31st December		9,325,393	8,752,045	5,971,570	5,411,866

As at 31st December	Consolidated		Company	
	2014 Rs. '000	2013 Rs. '000	2014 Rs. '000	2013 Rs. '000
20. AVAILABLE-FOR-SALE RESERVE				
Balance as at 1st January	15,364,711	12,521,041	15,364,711	12,521,041
Recognised in Other Comprehensive Income for the Year	11,160,541	2,843,670	11,160,541	2,843,670
Balance as at 31st December	26,525,252	15,364,711	26,525,252	15,364,711

Available-For-Sale Reserves comprise of the impact arising from the changes in market values of Financial Assets classified under Available-For-Sale (AFS).

As at 31st December	Note	Consolidated		Company	
		2014 Rs. '000	2013 Rs. '000	2014 Rs. '000	2013 Rs. '000
21. REVENUE RESERVE					
General Reserve		643,442	643,442	643,442	643,442
Surplus from Life Insurance	21.1	4,450,665	4,528,867	4,450,665	4,528,867
Policyholder Reserve Fund	21.2	(3,328,928)	(510,889)	(3,328,928)	(510,888)
Retained Earnings	21.3	35,734,633	28,617,542	23,954,309	21,737,166
		37,499,812	33,278,962	25,719,488	26,398,587

21.1 SURPLUS FROM LIFE INSURANCE

Balance as at 1st January		4,528,867	8,268,739	4,528,867	8,268,739
Surplus Attributable to Shareholders from Life Insurance		1,612,402	1,721,809	1,612,402	1,721,809
Transferred to Shareholders		(1,690,604)	(5,461,681)	(1,690,604)	(5,461,681)
Balance as at 31st December		4,450,665	4,528,867	4,450,665	4,528,867

21.2 POLICYHOLDER RESERVE FUND

Balance as at 1st January		(510,888)	806,271	(510,888)	806,271
Change in Fair Value Measurements Applicable to Life Contract Liability	22	(2,818,040)	(1,317,160)	(2,818,040)	(1,317,160)
Balance as at 31st December		(3,328,928)	(510,889)	(3,328,928)	(510,888)

The Life Policyholder Reserve Fund includes the initial impact of the implementation of SLFRSs/LKASs w.e.f. 1st January 2012 and the fair value gains and losses recorded under Other Comprehensive Income in respect of Life Insurance related to Available-For-Sale financial assets since then.

As at 31st December	Consolidated		Company	
	2014 Rs. '000	2013 Rs. '000	2014 Rs. '000	2013 Rs. '000
21.3 RETAINED EARNINGS				
Balance as at 1st January	28,617,540	15,947,151	21,737,166	14,316,177
Profit for the Year	8,037,407	9,681,178	3,257,013	4,654,830
Other Comprehensive Income	(88,055)	8,420	(87,955)	5,992
Surplus Attributable to Shareholders from				
Life Insurance	(1,612,402)	(1,721,809)	(1,612,402)	(1,721,809)
Transfer from Life Division	1,690,604	5,461,681	1,690,604	5,461,681
Effect of Acquisition of Subsidiary and				
Changes in Holding	77,355	(68,857)	-	-
Deferred Tax on Revaluation Surplus Transfer	-	289,484	-	-
Transfer of Fair Value Gain on Investment Property	-	189,975	-	189,975
Realisation of Revaluation Surplus on Disposal	71,602	30,320	29,301	30,320
Dividend Declared and Paid	(1,002,000)	(1,200,000)	(1,002,000)	(1,200,000)
Share Buyback *	57,245	-	(57,245)	-
Balance as at 31st December	35,734,633	28,617,542	23,954,309	21,737,166

* During the year Company has re-purchased 57,245 million shares from its shareholders.

22. INSURANCE CONTRACT LIABILITIES - LIFE

Life Insurance Fund as at 1st January	66,511,608	60,084,899	66,511,608	60,084,899
Movement of the Fund	6,988,818	6,831,358	6,988,818	6,831,358
Transferred from Life Policyholders Reserve Fund	2,818,040	1,317,160	2,818,040	1,317,160
Surplus Distributed to Shareholders	(1,612,402)	(1,721,809)	(1,612,402)	(1,721,809)
Life Insurance Fund as at 31st December	74,706,064	66,511,608	74,706,064	66,511,608
Policyholder Outstanding Claims (Unclaimed Benefits)	2,548,432	2,567,453	2,548,432	2,567,453
	77,254,496	69,079,061	77,254,496	69,079,061

Contract liability included in the Life Insurance Fund, Consist of traditional participating and non-participating life insurance products liabilities. The insurance provision has been established based upon the following:

- Interest rate which is prescribed under IBSL Guidelines.
- Mortality rates used are A 67/70 for non-annuity business and a(90)m for male annuitants and (90)f for female annuitant which are prescribed under IBSL Guidelines .

The amount of policyholder's reversionary bonus to be paid is determined annually by the Company. The bonus includes life policyholders share of net income that are required to be allocated by the insurance contract or, by insurance regulations.

The valuation of the Insurance Provision – Life Insurance Business, as at 31st December 2014 was made by Mark Alan Birch, Fellow of the Institute and Faculty of Actuaries UK, of Towers Watson, for and on behalf of Sri Lanka Insurance Corporation Ltd. In accordance with the consultants actuary's report, the sum of provision, Rs: 2,699 million (in - 2013 Rs. 2,579 million), is included as the liability in respect of policyholders' Bonus. In the opinion of the consultant actuary, the admissible assets of the life insurance fund as at 31st December 2014 is adequate to cover the liabilities of the fund and the solvency margin requirement prescribed under Section 26 of the regulation of Insurance Industry Act No. 43 of 2000. The life fund also carried forward surplus for future growth and contingencies.

The Life Insurance Fund assets inclusive of Shareholders' Transfer as at 31st December 2014 is Rs. 76,318 million (2013 – Rs. 68,233 million). The Board of Directors decided to transfer Rs. 1,612 million (2013 – Rs. 1,722 million) to the Shareholders' Fund in the Statement of Financial Position in life insurance. Subsequent to this transfer, the life insurance fund stands Rs. 74,706 million (2013 - Rs. 66,512 million).

LIABILITY ADEQUACY TEST (LAT) – LIFE INSURANCE

A Liability Adequacy Test ('LAT') for life insurance contract liability was carried out by Mark Alan Birch, Fellow of the Institute and Faculty of Actuaries, UK, of Towers Watson, as at 31st December 2014 as required by SLFRS 4 - 'Insurance Contracts.' When performing the LAT, the Company has compared the provisions held as per audited accounts with the actuarial liability. For this purpose, the value of the actuarial liability is computed following the principles laid out within Risk-Based Capital Framework as prescribed by the IBSL, whereby liabilities are valued using a discounted cash-flow approach covering the full lifetime of all cash in- and out-flows required to settle the obligations related to existing in-force life insurance contracts. The projections are based on in-force policies and riders as at 31st December 2014.

According to the actuary's report, assets are sufficiently adequate as compared to the discounted cash flow reserves and in contrast to the reserves as at 31st December 2014. No additional provision is required against the LAT as at 31st December 2014.

23. INSURANCE CONTRACT LIABILITIES – NON-LIFE

The Non-Life Insurance Reserves as shown in the Statement of Financial Position represents the following:

As at 31st December	Note	Consolidated		Company	
		2014 Rs. '000	2013 Rs. '000	2014 Rs. '000	2013 Rs. '000
Reserves for Net Unearned Premium	23.1	5,235,223	5,034,687	5,235,223	5,034,687
Reserves for Title Insurance and Unexpired Risk Reserve	23.2	251,594	436,468	251,594	436,468
Reserves for Gross Outstanding Claims	23.3	7,708,966	7,817,801	7,708,966	7,817,801
		13,195,783	13,288,956	13,195,783	13,288,956

23.1 RESERVE FOR NET UNEARNED PREMIUM**Reserve for Unearned Premium**

Balance as at 1st January	6,896,179	6,449,789	6,896,179	6,449,789
Transfer during the Year	309,921	446,390	309,921	446,390
Balance as at 31st December	7,206,100	6,896,179	7,206,100	6,896,179

Reserve for Unearned Reinsurance Premium

Balance as at 1st January	(1,861,492)	(1,598,252)	(1,861,492)	(1,598,252)
Transfer during the Year	(109,385)	(263,241)	(109,385)	(263,241)
Balance as at 31st December	(1,970,877)	(1,861,492)	(1,970,877)	(1,861,492)
Total Reserve for Net Unearned Premium	5,235,223	5,034,687	5,235,223	5,034,687

As at 31st December	Consolidated		Company	
	2014 Rs. '000	2013 Rs. '000	2014 Rs. '000	2013 Rs. '000
23.2 RESERVE FOR TITLE INSURANCE AND UNEXPIRED RISK RESERVE				
Reserve for Title Insurance				
Balance as at 1st January	436,468	301,108	436,468	301,108
Transfer during the Year	(184,874)	135,360	(184,874)	135,360
Balance as at 31st December	251,594	436,468	251,594	436,468
Reserve for Unexpired Risk Reserve				
Balance as at 1st January	-	487,847	-	487,847
Transfer during the Year	-	(487,847)	-	(487,847)
Balance as at 31st December	-	-	-	-
Reserve for Reinsurance Unexpired Risk Reserve				
Balance as at 1st January	-	(59,043)	-	(59,043)
Transfer during the Year	-	59,043	-	59,043
Balance as at 31st December	-	-	-	-
Total Reserve for Title Insurance and Unexpired Risk Reserve	251,594	436,468	251,594	436,468
23.3 RESERVES FOR GROSS OUTSTANDING CLAIMS - NON-LIFE				
Balance as at 1st January	5,228,781	6,239,151	5,228,781	6,239,151
Claims Incurred during the Year	6,866,601	5,330,509	6,866,601	5,330,509
Claims Paid during the Year	(6,568,888)	(6,340,879)	(6,568,888)	(6,340,879)
Balance as at 31st December	5,526,494	5,228,781	5,526,494	5,228,781
IBNR/IBNER Balance as at 1st January	2,589,019	2,477,202	2,589,019	2,477,202
Increase in IBNR/IBNER	(406,547)	111,817	(406,547)	111,817
IBNR/IBNER Balance as at 31st December	2,182,472	2,589,019	2,182,472	2,589,019
Total Reserves for Gross Outstanding Claims	7,708,966	7,817,801	7,708,966	7,817,801

Significant delays occur in the notification of claims and a substantial measure of experience and judgment is involved in assessing outstanding liabilities, the ultimate cost of which cannot be known with certainty as of the reporting date. The reserves are determined based on the information currently available. However, it is inherent to the nature of the business written that the ultimate liability may vary as a result of subsequent developments.

LIABILITY ADEQUACY TEST (LAT) – NON-LIFE INSURANCE

A Liability Adequacy Test ("LAT") for Non-Life Insurance contract liability was carried out by Mr. Matthew Maguire, Fellow of the Australian Actuarial Society (AAG) on behalf of Sri Lanka Insurance Corporation Ltd. as at 31st December 2014 as required by SLFRS 4 – Insurance Contracts. The LAT is performed to assess the adequacy of the carrying amount of the Unearned Premium Reserve (UPR). According to the Consultant Actuary's Report, the Company adequately satisfies the LAT as at 31st December 2014. No additional provision was required against the LAT as at 31st December 2014.

As at 31st December	Consolidated		Company	
	2014 Rs. '000	2013 Rs. '000	2014 Rs. '000	2013 Rs. '000
Reconciliation between Insurance Contract Liabilities Non-Life and Technical Reserves				
Insurance Contract Liabilities Non-Life	13,195,783	13,288,956	13,195,783	13,288,956
Reserve for Net Deferred Acquisition Expenses	(261,860)	(246,896)	(261,860)	(246,896)
Reinsurance on Claims Reserves	(1,003,992)	(1,160,449)	(1,003,992)	(1,160,449)
Technical Reserves	11,929,931	11,881,611	11,929,931	11,881,611

23.4 CLAIMS DEVELOPMENT INFORMATION

Table below presents changes in the historical non-life reserves, net of reinsurance. The top line of the table shows the estimated gross reserves for unpaid losses and loss adjustment expenses as of each reporting date, which represents the estimated amount of future payments for losses incurred in that year and in prior years. The cumulative paid portion of the table presents the cumulative amounts paid through each subsequent year in respect of the reserves established at each year-end. Similarly, the cumulative reported losses section details the sum of the cumulative paid amounts shown in the triangle above and the net outstanding position at the end of the financial year.

As at 31st December	2009 Rs.	2010 Rs.	2011 Rs.	2012 Rs.	2013 Rs.	2014 Rs.
Gross reserves for losses and loss adjustment expenses	6,146,598,253	6,759,172,132	7,898,096,692	8,720,582,620	7,817,800,636	7,709,470,517
Reinsurance recoverable	(942,908,191)	(1,361,271,745)	(1,168,930,136)	(1,509,187,974)	(1,160,448,524)	(1,004,432,194)
Net reserves for losses and loss adjustment expenses	5,203,690,062	5,397,900,387	6,729,166,557	7,211,394,645	6,657,352,112	6,705,038,323

Cumulative paid as of 31st December:

One year later	2,777,513,593	2,874,874,128	3,632,757,028	4,545,085,355	4,481,213,520	4,572,092,748
Two years later	3,522,688,732	3,714,910,249	4,903,405,392	5,908,837,239	5,873,385,629	
Three years later	3,570,404,152	3,788,276,570	4,980,092,970	6,016,063,272		
Four years later	3,589,944,991	3,806,053,537	5,014,506,148			
Five years later	3,615,680,225	3,832,694,904				
Six years later	3,647,979,624					

Cumulative Reported as of 31st December:

One year later	3,679,732,673	3,877,357,626	4,740,384,794	5,765,263,148	5,564,838,084	5,631,797,127
Two years later	3,890,505,082	4,091,340,643	5,147,257,128	6,199,143,542	6,107,020,752	
Three years later	3,805,274,933	4,020,496,575	5,195,146,471	6,287,566,401		
Four years later	3,705,919,728	3,995,269,295	5,289,158,538			
Five years later	3,711,999,165	4,110,863,857				
Six years later	3,843,689,041					

As at 31st December	Consolidated		Company	
	2014 Rs. '000	2013 Rs. '000	2014 Rs. '000	2013 Rs. '000

24. CURRENT TAX LIABILITIES

Balance as at 1st January	2,895,797	1,608,096	1,739,675	1,071,066
Income Tax Charge for the Year	2,785,703	3,430,737	1,308,460	1,761,639
Income Tax Settlements Made during the Year	(4,208,954)	(2,260,289)	(2,084,970)	(1,093,030)
At the End of the Year	1,472,546	2,778,544	963,165	1,739,675

As at 31st December	Consolidated		Company	
	2014 Rs. '000	2013 Rs. '000	2014 Rs. '000	2013 Rs. '000
25. DEFERRED TAX				
<i>Deferred Tax Liabilities</i>				
<i>Capital Allowances for Tax Purposes</i>				
Purposes	2,590,603	2,396,092	955,494	1,044,913
Revaluation/(Deficit) of Building	553,027	600,057	3,778	-
	3,143,630	2,996,149	959,272	1,044,913
Deferred Tax Assets				
Defined Benefit Obligations	(130,360)	(97,352)	(97,642)	(67,655)
Impairment on Trade Receivables	(118,574)	(42,628)	(118,574)	(41,602)
Tax Loss Carried Forward	(60,068)	(45,626)	-	-
Impairment on Inventories	-	(2,174)	-	-
	(309,002)	(187,779)	(216,216)	(109,257)
Net Deferred Tax Liabilities	2,834,628	2,808,369	743,056	935,656
Company				
As at 31st December	2014		2013	
	Temporary Difference Rs. '000	Tax Effect Rs. '000	Temporary Difference Rs. '000	Tax Effect Rs. '000
Deferred Tax Liabilities				
Capital Allowances for Tax Purposes	3,412,479	955,494	3,731,832	1,044,913
Revaluation Surplus/(Deficit) of Building	13,493	3,778	-	-
	3,425,971	959,272	3,731,832	1,044,913
Deferred Tax Assets				
Defined Benefit Obligations	(348,721)	(97,642)	(241,626)	(67,655)
Impairment on Trade Receivables	(423,479)	(118,574)	(148,579)	(41,602)
	(772,200)	(216,216)	(390,205)	(109,257)
Net Deferred Tax Liabilities	2,653,771	743,056	3,341,628	935,656

As at 31st December	Consolidated			
	2014		2013	
	Temporary Difference Rs. '000	Tax Effect Rs. '000	Temporary Difference Rs. '000	Tax Effect Rs. '000
Deferred Tax Liability				
Capital Allowances for Tax Purposes	10,162,529	2,590,603	9,399,493	2,396,092
Revaluation Surplus/(Deficit) of Building	2,632,281	553,027	2,856,131	600,057
	12,794,810	3,143,630	12,255,624	2,996,149
Deferred Tax Assets				
Defined Benefit Obligations	(3,230,303)	(130,360)	(2,412,357)	(97,352)
Provision for Doubtful Debtors	(208,951)	(118,574)	(75,119)	(42,628)
Tax Loss Carried Forward	(214,528)	(60,068)	(162,950)	(45,626)
Impairment on Inventories	-	-	(7,763)	(2,174)
	(3,653,781)	(309,002)	(2,658,189)	(187,779)
Net Deferred Tax Liabilities	9,141,028	2,834,628	9,597,435	2,808,369

As at 31st December	Consolidated		Company	
	2014	2013	2014	2013
	Rs. '000	Rs. '000	Rs. '000	Rs. '000
26. EMPLOYEE BENEFITS				
Balance as at 1st January	635,244	547,212	463,117	401,759
Current Service Cost	73,522	49,994	39,570	28,395
Interest Expenses	63,699	59,464	46,312	44,194
Actuarial (Gain)/Loss	127,024	(8,554)	122,160	(5,992)
	899,489	648,117	671,159	468,356
Benefit Paid during the Year	(26,914)	(12,873)	(2,778)	(5,239)
Balance as at 31st December	872,575	635,244	668,381	463,117

26.1 Mr. M. Poopalanathan, AIA, of The Group's Gratuity Liability was actuarially valued under the Projected Unit Credit (PUC) method by Messrs Actuarial & Management Consultants (Pvt) Ltd., 1st Floor, No. 434, R.A. De Mel Mawatha, Colombo 3. The actuarial valuation is performed annually.

	Consolidated		Company	
	2014 Rs. '000	2013 Rs. '000	2014 Rs. '000	2013 Rs. '000
26.2 GRATUITY EXPENSE RECOGNISED IN THE STATEMENT OF COMPREHENSIVE INCOME				
Current Service Cost	73,522	49,994	39,570	28,395
Interest on Obligation	63,699	59,464	46,312	44,194
	137,221	109,459	85,882	72,589

26.3 GRATUITY EXPENSE RECOGNISED IN THE STATEMENT OF OTHER COMPREHENSIVE INCOME				
Actuarial Losses/(gains)	127,024	(8,554)	122,160	(5,992)

26.4 PRINCIPAL ACTUARIAL ASSUMPTIONS USED

	2014 %	2013 %
Discount Rate	9 - 10	9 - 12
Salary Increment Rate	5 - 10	5 - 10
Staff Turnover Factor	16 - 10	10
Retirement Age; Female	60 years	60 years
Retirement Age; Male	60 years	60 years
Retirement Age; Minor Staff	57 years	57 years

The Group's Gratuity Liability is not externally funded.

26.5 SENSITIVITY ANALYSIS

Reasonable possible changes at the reporting date to one of the relevant actuarial assumptions, holding other assumptions constant, would have affected the defined obligation by the amounts shown below:

As at 31st December	2014	
	Increase Rs. '000	Decrease Rs. '000
Discount rate 1%	615,505	708,576
Future salary growth 1%	617,139	705,895

As at 31st December	Consolidated		Company	
	2014 Rs. '000	2013 Rs. '000	2014 Rs. '000	2013 Rs. '000

27. OTHER LIABILITIES

Policyholder Advance Payments	499,336	354,163	499,336	354,163
Agency Commission Payable	934,941	867,984	934,941	867,984
Income Tax Payable	-	117,253	-	-
Economic Services Charge Tax	343	2,684	-	-
Accrued Expenses	2,410,125	1,989,927	1,904,151	1,989,927
Riot Fund	65,331	59,106	65,331	59,106
Trade Payable	1,804,705	2,477,590	-	-
VAT Payable	32,684	22,925	-	-
Provision for assessment on VAT Liability	345,000	345,000	345,000	345,000
Other Payables	527,291	1,183,591	-	-
Advance Received	54,212	43,735	-	-
Customer Deposit Payable	4,569,545	4,323,978	-	-
Total Other Liabilities	11,243,513	11,787,935	3,748,759	3,616,179

As at 31st December	Consolidated		Company	
	2014 Rs. '000	2013 Rs. '000	2014 Rs. '000	2013 Rs. '000
28. BANK OVERDRAFT				
Bank Overdraft	599,328	496,776	388,907	361,721
	599,328	496,776	388,907	361,721

For the Year Ended 31st December	Note	Consolidated		Company	
		2014 Rs. '000	2013 Rs. '000	2014 Rs. '000	2013 Rs. '000
29. REVENUE					
Gross Written Premium	30	20,584,486	21,262,140	20,665,985	21,350,869
Net Change in Reserve for Unearned Premium	29.1	(125,047)	(581,750)	(125,047)	(581,750)
Gross Earned Premium		20,459,439	20,680,390	20,540,938	20,769,119
Premium Ceded to Reinsurers	29.2	(2,845,418)	(3,227,303)	(2,845,418)	(3,227,303)
Net Change in Reserve for Unearned Reinsurance Premium	29.3	109,385	263,241	109,385	263,241
Net Earned Premium	29.4	17,723,406	17,716,327	17,804,905	17,805,056
Income from Investments	31	11,708,619	8,895,213	11,216,572	9,275,562
Other Income		1,075,532	1,323,566	280,503	900,233
Hospital Revenue		3,706,401	3,081,541	-	-
Pharmacy Revenue		1,047,188	872,569	-	-
Room Rental and Services Charges		24,960	79,155	-	-
Revenue from Liquid Petroleum Gas (LPG) Activities		28,937,543	28,106,333	-	-
		64,223,649	60,074,704	29,301,980	27,980,852

Sinolanka Hotels & Spa (Pvt) Ltd. a subsidiary of SLIC, is in the process of constructing the Hyatt Regency Colombo Hotel.

For the Year Ended 31st December	Note	Consolidated		Company	
		2014 Rs. '000	2013 Rs. '000	2014 Rs. '000	2013 Rs. '000
29.1 NET CHANGE IN RESERVE FOR UNEARNED PREMIUM					
Non-Life Insurance					
Change in Reserve for Unearned Premium	23.1	(309,921)	(446,390)	(309,921)	(446,390)
Transfer to Title Insurance Reserve	23.2	184,874	(135,360)	184,874	(135,360)
		(125,047)	(581,750)	(125,047)	(581,750)

As at 31st December		Consolidated		Company	
		2014 Rs. '000	2013 Rs. '000	2014 Rs. '000	2013 Rs. '000

29.2 PREMIUMS CEDED TO REINSURERS

Life Insurance		136,401	97,636	136,401	97,636
		136,401	97,636	136,401	97,636
Non-Life Insurance					
Fire		1,394,800	1,688,446	1,394,800	1,688,446
Motor		164,882	170,004	164,882	170,004
Marine		280,430	275,849	280,430	275,849
Miscellaneous		868,905	995,368	868,905	995,368
		2,709,017	3,129,667	2,709,017	3,129,667
Total Premium Ceded to Reinsurers		2,845,418	3,227,303	2,845,418	3,227,303

For the Year Ended 31st December	Note	Consolidated		Company	
		2014 Rs. '000	2013 Rs. '000	2014 Rs. '000	2013 Rs. '000

29.3 NET CHANGE IN RESERVE FOR UNEARNED REINSURANCE PREMIUM

Non-Life Insurance					
Premium	23.1	109,385	263,241	109,385	263,241
		109,385	263,241	109,385	263,241
		(15,662)	(318,510)	(15,662)	(318,510)

For the Year Ended 31st December	Consolidated/Company					
	2014			2013		
	Non-Life Rs. '000	Life Rs. '000	Total Rs. '000	Non-Life Rs. '000	Life Rs. '000	Total Rs. '000
29.4 NET EARNED PREMIUMS						
Gross Written Premium	12,544,828	8,121,159	20,665,987	12,953,151	8,397,718	21,350,869
Change in Reserve for Unearned Premium	(309,921)	-	(309,921)	(446,390)	-	(446,390)
Gross Earned Premium	12,234,907	8,121,159	20,356,066	12,506,761	8,397,718	20,904,479
Premiums Ceded to Reinsurers	2,709,017	136,401	2,845,418	3,129,667	97,636	3,227,303
Change in Reserve for Unearned Reinsurance Premium	(109,385)	-	(109,385)	(263,241)	-	(263,241)
Gross Reinsurance Premium	2,599,632	136,401	2,736,033	2,866,426	97,636	2,964,063
Transfer to Title Insurance Reserve	184,874	-	184,874	135,360	-	135,360
	2,414,758	136,401	2,551,158	3,001,787	97,636	3,099,423
Net Earned Premium	9,820,150	7,984,758	17,804,908	9,504,974	8,300,082	17,805,056

For the year ended 31st December	Consolidated		Company	
	2014	2013	2014	2013
	Rs. '000	Rs. '000	Rs. '000	Rs. '000

30. GROSS WRITTEN PREMIUM

Life Insurance

Gross Written Premium – Life Insurance	8,039,660	8,308,989	8,121,159	8,397,718
---	------------------	-----------	------------------	-----------

Non-Life Insurance

Fire and Engineering Risk	1,553,150	1,867,398	1,553,150	1,867,398
General Accident	3,384,287	3,291,840	3,384,287	3,291,840
Marine	402,133	377,535	402,133	377,535
Workmen's Compensation	-	83,964	-	83,964
Motor	7,205,256	7,332,414	7,205,256	7,332,414
Gross Written Premium – Non-Life Insurance	12,544,826	12,953,151	12,544,826	12,953,151
Total Gross Written Premium	20,584,486	21,262,140	20,665,985	21,350,869

<i>For the year ended 31st December</i>	Note	Consolidated		Company	
		2014 Rs. '000	2013 Rs. '000	2014 Rs. '000	2013 Rs. '000
31. INVESTMENT INCOME					
Interest Income	31.1	8,448,367	7,855,339	7,697,430	7,855,339
Dividends Income	31.2	1,337,454	1,436,041	1,646,244	1,816,390
Capital Gains/(Losses)	31.3	1,831,470	(437,595)	1,831,470	(437,595)
Rental Income from Investment Properties		91,328	41,428	41,428	41,428
		11,708,619	8,895,213	11,216,572	9,275,563

<i>For the year ended 31st December</i>		Consolidated		Company	
		2014 Rs. '000	2013 Rs. '000	2014 Rs. '000	2013 Rs. '000

31.1 INTEREST INCOME**Financial Investments at Held-To-Maturity (HTM)**

Treasury Bonds		3,119,130	2,138,965	3,119,130	2,138,965
Treasury Bills		22,637	33,583	22,637	33,583

Financial Investments at Loans and Receivables (L&R)

Development Bonds		176,165	219,588	176,165	219,588
Unlisted Debentures		161,128	280,024	161,128	280,024
Term Deposits		2,194,104	2,557,840	2,066,708	2,557,840
Commercial Papers		-	23,281	-	23,281
Trust Certificates		1,387	6,650	1,387	6,650

Financial Investments at Available-For-Sale (AFS)

Treasury Bonds		517,367	886,084	517,367	886,084
Treasury Bills		256,472	13,113	20,833	13,113
Listed Debentures		998,142	590,797	998,142	590,797

<i>For the year ended 31st December</i>	Consolidated		Company	
	2014 Rs. '000	2013 Rs. '000	2014 Rs. '000	2013 Rs. '000
Cash and Cash Equivalents				
Reverse Repurchase Agreements	995,145	1,101,754	609,735	1,101,754
Call & Savings Accounts	6,690	2,799	4,198	2,799
Other Fee Based Income				
Participation Fees – Listed Debentures	-	861	-	861
Total Interest Income	8,448,367	7,855,339	7,697,430	7,855,339

31.2 DIVIDEND INCOME

Financial Investments at Cost

Listed Subsidiaries	-	-	61,089	244,356
Unlisted Subsidiaries	-	-	247,701	135,993

Financial Investments at Available-For-Sale (AFS)

Listed Shares	1,082,309	1,161,635	1,082,309	1,161,635
Unlisted Shares	4,298	3,598	4,298	3,598
Unit Trusts	108,573	78,654	108,573	78,654

Financial Investments at Fair-Value-Through-Profit-or-Loss (FVTPL)

Listed Shares	142,274	192,154	142,274	192,154
Total Dividend Income	1,337,454	1,436,041	1,646,244	1,816,390

31.3 CAPITAL GAINS/(LOSSES)

Financial Investments at Available-For-Sale (AFS)

Listed Shares	18,070	-	18,070	-
Unit Trusts	389,772	-	389,772	-

Financial Investments at Fair-Value-Through-Profit-or-Loss (FVTPL)

Listed Shares	1,423,628	(437,595)	1,423,628	(437,595)
Total Capital Gains/(Losses)	1,831,470	(437,595)	1,831,470	(437,595)

<i>For the year ended 31st December</i>	Consolidated		Company	
	2014 Rs. '000	2013 Rs. '000	2014 Rs. '000	2013 Rs. '000
32. FEES AND COMMISSION INCOME				
Reinsurance Commission	46,612	25,087	46,612	25,087
Policy Fees	2,684	2,795	2,684	2,795
	49,296	27,881	49,296	27,881

<i>For the year ended 31st December</i>	Consolidated		Company	
	2014 Rs. '000	2013 Rs. '000	2014 Rs. '000	2013 Rs. '000
33. NET REALISED GAINS/(LOSSES)				
Foreign Currency Gains/(Losses)	(152,291)	39,906	(157,737)	39,906
	(152,291)	39,906	(157,737)	39,906

<i>For the year ended 31st December</i>	Consolidated		Company	
	2014 Rs. '000	2013 Rs. '000	2014 Rs. '000	2013 Rs. '000
34. OTHER INCOME				
Rent Income	84,360	46,438	74,410	57,363
Loans	301,733	309,229	301,733	309,229
Sundry Income	794,554	904,195	15,082	474,227
Gain/(Loss) on Disposal of Property, Plant & Equipment	(2,120)	8,588	(2,281)	4,298
	1,178,527	1,268,450	388,944	845,117

<i>For the year ended 31st December</i>	Consolidated		Company	
	2014 Rs. '000	2013 Rs. '000	2014 Rs. '000	2013 Rs. '000
35. NET BENEFIT AND CLAIMS				
(a) Gross Benefits and Claims Paid				
Non-Life Insurance				
Fire	230,196	228,919	230,196	228,919
Motor	4,126,087	4,104,179	4,126,087	4,104,179
Marine	164,245	166,597	164,245	166,597
Miscellaneous	2,048,359	1,841,183	2,048,359	1,841,183
Total	6,568,887	6,340,879	6,568,887	6,340,879
Life Insurance				
Death Claims	315,939	239,916	315,939	239,916
Policy Maturities	5,012,580	4,135,785	5,012,580	4,135,785
Surrenders	356,446	308,768	356,446	308,768
Disability, Ex-gratia, Annuities, Hospitalisation and Mortgage Protection	74,028	95,548	74,028	95,548
Total	5,758,993	4,780,017	5,758,993	4,780,017
Total Gross Benefits and Claims Paid	12,327,880	11,120,896	12,327,880	11,120,896
(b) Claims Ceded to Reinsurers				
Claims Recovered from Reinsurers	(436,246)	(461,340)	(436,246)	(461,340)
Total Claims Ceded to Reinsurers	(436,246)	(461,340)	(436,246)	(461,340)
(c) Gross Change in Contract Liabilities				
Change in Non-Life Insurance Contract Outstanding Claims Provision	(108,330)	(772,003)	(108,330)	(772,003)
Change in Premium Deficiency Provision	-	(428,805)	-	(428,805)
Total Gross Change in Contract Liabilities	(108,330)	(1,200,808)	(108,330)	(1,200,808)
(d) Change in Contract Liabilities Ceded to Reinsurers				
Change in Non-Life Insurance Contract Outstanding Claims Provision	156,016	345,735	156,016	345,735
Total Change in Contract Liabilities Ceded to Reinsurers	-	-	-	-
Total Change in Contract Liabilities Ceded to Reinsurers	156,016	345,735	156,016	345,735
Total Net Benefits and Claims	11,939,320	9,804,484	11,939,320	9,804,484

<i>For the year ended 31st December</i>	Consolidated		Company	
	2014 Rs. '000	2013 Rs. '000	2014 Rs. '000	2013 Rs. '000
36. UNDERWRITING AND NET ACQUISITION COSTS(INCLUDING REINSURANCE)				
Acquisition Cost	1,939,842	1,885,522	1,939,842	1,885,522
Net Change in Reserve for Deferred Acquisition Cost (DAC)	(9,704)	(10,094)	(9,704)	(10,094)
	1,930,138	1,875,428	1,930,138	1,875,428
Reinsurance Commission Received	311,636	306,135	311,636	306,135
Net Change in Reserve for Unearned Commission (UCR)	(5,260)	(15,366)	(5,260)	(15,366)
	316,896	321,500	316,896	321,500
Net Acquisition Costs and Underwriting	1,613,242	1,553,928	1,613,242	1,553,928

<i>For the year ended 31st December</i>	Consolidated		Company	
	2014 Rs. '000	2013 Rs. '000	2014 Rs. '000	2013 Rs. '000
37. OTHER OPERATING AND ADMINISTRATION EXPENSES				
Other Operating and Administration Expenses Includes Following:				
Audit Fees	7,289	6,609	3,900	3,600
Audit-Related Fees	1,239	1,762	1,000	1,400
Fees for Non-Audit Services	12,645	1,638	12,645	1,514
Depreciation	1,494,717	393,780	385,994	369,353
Amortisation of Intangible Assets	46,812	34,021	43,471	34,021
Amortisation of Advanced Lease Premium	4,766	4,907	-	-
Amortisation of Leasehold Land	848	493	269	269
Staff Benefits	3,988,233	2,493,786	2,093,475	2,093,475

For the year ended 31st December	Consolidated		Company	
	2014 Rs. '000	2013 Rs. '000	2014 Rs. '000	2013 Rs. '000
38. INCOME TAX EXPENSE				
Current Tax Expense				
Income Tax on Current Year Profit	2,822,581	3,470,436	1,308,460	1,761,639
Over Provision in Previous Years	(36,878)	(10,768)	-	-
	2,785,703	3,459,668	1,308,460	1,761,639
Deferred Tax Expense				
Origination/(Reversal) of Temporary Differences	27,751	198,720	(192,334)	(61,600)
Income Tax Expenses Reported in the Income Statement	2,813,454	3,658,388	1,116,126	1,700,039
Income Tax Expense Reported in the Statement of Changes in Equity	(35,313)	(338)	(34,205)	-
Income Tax Expense Reported in the Income Statement	2,778,141	3,658,050	1,081,921	1,700,039
38.1 RECONCILIATION OF EFFECTIVE TAX RATE				
Profit for the Year before Change in Contract Liabilities - Life Fund	16,529,538	18,906,728	9,749,555	11,464,419
Change in Contract Liabilities - Life Fund	(5,376,416)	(5,109,549)	(5,376,416)	(5,109,549)
Profit for the Year before Tax	11,153,122	13,797,179	4,373,139	6,354,870
Current Tax Expense (Including Deferred Tax on Revaluation)	(2,813,454)	(3,658,388)	(1,116,126)	(1,700,039)
Profit for the Year	8,339,668	10,138,791	3,257,013	4,654,830
At the Statutory Income Tax Rate (28%)	4,605,867	5,417,208	2,768,526	3,211,719
At the Statutory Income Tax Rate (12%)	62,636	-	-	-
Income Exempt from Tax	(1,014,813)	(927,042)	(624,737)	(596,143)
Aggregate Allowable Expenses	(1,368,623)	(1,022,848)	(1,058,598)	(1,005,882)
Aggregate Disallowable Expenses	617,698	3,602	223,269	151,946
Tax Loss Utilised during the Year	(80,183)	(484)	-	-
Over Provision for Income Tax in Respect of Prior Year	(36,878)	(10,768)	-	-
Deferred Taxation Charge/(Reversal)	27,751	198,720	(192,334)	(61,600)
Income Tax Expense Reported in the Statement of Changes in Equity	(35,313)	(338)	(34,205)	-
Current Tax Expense	2,813,454	3,658,388	1,116,126	1,700,039

<i>For the year ended 31st December</i>	Consolidated			
	2014		2013	
	Temporary Difference Rs. '000	Tax Effect Rs. '000	Temporary Difference Rs. '000	Tax Effect Rs. '000
38.2 DEFERRED TAXATION				
Deferred Tax Liability				
Capital Allowances for Tax Purposes	10,186,100	2,596,603	9,399,493	2,396,092
Revaluation Surplus/(Deficit) of Building	2,607,579	550,062	2,856,131	600,057
	12,794,810	3,143,630	12,255,624	2,996,149
Deferred Tax Assets				
Defined Benefits Obligations	(3,230,303)	(130,360)	(2,412,357)	(97,352)
Provision for Doubtful Debtors	(208,951)	(118,574)	(75,119)	(42,628)
Tax Loss Carried Forward	(214,528)	(60,068)	(162,950)	(45,626)
Provision for Stocks	-	-	(7,763)	(2,174)
	(3,653,781)	(309,002)	(2,658,189)	(187,779)
Net Deferred Tax Liability	9,141,028	2,834,628	9,597,435	2,808,369
Company				
<i>For the year ended 31st December</i>	2014		2013	
	Temporary Difference Rs. '000	Tax Effect Rs. '000	Temporary Difference Rs. '000	Tax Effect Rs. '000
	Deferred Tax Liability			
Capital Allowances for Tax Purposes	3,412,479	955,494	3,731,832	1,044,913
Revaluation Surplus/(Deficit) of Building	13,493	3,778	-	-
	3,425,971	959,272	3,731,832	1,044,913
Deferred Tax Assets				
Defined Benefit Obligations	(348,721)	(97,642)	(241,626)	(67,655)
Provision for Doubtful Debtors	423,479	118,574	148,579	41,602
	(772,200)	(216,216)	(390,205)	(109,257)
Net Deferred Tax Liability	2,653,771	743,056	3,341,628	935,656

The Company is liable to income tax of 28% in terms of Inland Revenue Act No. 10 of 2006 and amendments thereto. Current year tax charge consists of income tax charge on General Insurance and investment income in Life Insurance.

Litro Gas Terminal Lanka (Pvt) Ltd. and Litro Gas Lanka Ltd. business profits are exempted from income tax for a period of 15 years according to the agreement entered into by the Litro Gas Terminal Lanka (Pvt) Ltd. and Litro Gas Lanka Ltd. with the Board of Investment of Sri Lanka (BOI). The said exemption period commenced in 2000 and will expire in 2015. Accordingly, the current year income tax represents the income tax charge on interest income received during the year at the rate of 28% (2013 - 28%).

In accordance with and subject to the power conferred on the Board of Investment of Sri Lanka, under Section 17 of the BOI Law No. 4 of 1978, the operating profits and income accruing to The Lanka Hospitals Corporation PLC was exempt from tax for a period of 12 years from 2002. Accordingly, the tax exemption period ended in June 2014. After expiry of tax exemption period the business profit is taxable at a rate of 12%. However, in view of tax losses incurred on main business activities subsequent to the expiry of tax holiday period, the Company is liable for income tax for the period from July 2014 to December 2014.

Lanka Hospitals Diagnostics (Pvt) Ltd., is exempt from tax for a period of 7 years commencing from year in which the enterprise commences to make profits or any year of assessment not later than two years reckoned from the date of commencement of commercial operations whichever comes first.

Under the Strategic Development Projects Act No. 14 of 2008, the provisions of the Inland Revenue Act relating to income tax shall not apply to the profit from business of Sinolanka Hotels & Spa (Pvt) Ltd., for a period of 10 years.

Canowin Hotels and Spas (Pvt) Ltd., is liable to income tax of 28% in terms of Inland Revenue Act No. 10 of 2006 and amendments thereto.

39. BASIC EARNINGS PER SHARE

Basic earnings per share is calculated by dividing the net profit for the year attributable to ordinary shareholders by the weighted average number of ordinary shares outstanding during the year.

	Consolidated		Company	
	2014	2013	2014	2013
Amounts Used as the Numerators				
Net Profit Attributable to				
Ordinary Shareholders (Rs. '000)	8,037,407	9,681,178	3,257,013	4,654,830
Numbers of Ordinary Shares Used as Denominators				
Weighted Average Number of Ordinary Shares in Issue ('000)	599,743	600,000	599,743	600,000
Basic Earnings per Share (Rs.)	13.40	16.14	5.43	7.76

	Company	
	2014	2013
40. DIVIDEND PAID AND PROPOSED		
Dividend Paid/Proposed (Rs. '000)	2,003,141	1,002,000
Weighted Average Number of Ordinary Shares in Issue ('000)	599,743	600,000
Dividend per Share (Rs.)	3.34	1.67

41. FINANCIAL ASSETS AND LIABILITIES

41.1 ACCOUNTING CLASSIFICATIONS AND FAIR VALUE

The table below sets out the carrying amounts and fair values of the Company's financial assets and financial liabilities:

As at 31st December	Note	2014					Fair Value Total Rs. '000
		Fair-Value-Through-Profit-or-Loss Rs. '000	Available-For-Sale Rs. '000	Held-To-Maturity Rs. '000	Loans and Receivables Rs. '000	Carrying Value Total Rs. '000	
FINANCIAL ASSETS MEASURED AT FAIR VALUE							
Listed Shares	5	5,538,347	35,711,339	-	-	41,249,686	41,249,686
Unit Trusts	5	-	1,146,236	-	-	1,146,236	1,146,236
Listed Debentures	5	-	11,880,406	-	-	11,880,406	11,880,406
Treasury Bills and Bonds	5	-	4,387,187	-	-	4,387,187	4,387,187
Financial Assets Not Measured at Fair value **							
Treasury Bills and Bonds	5	-	-	26,076,867	-	26,076,867	29,832,970
Unlisted Debentures	5	-	-	-	1,367,206	1,367,206	1,364,944
Term Deposits	5	-	-	-	27,945,441	27,945,441	27,945,441
Development Bonds	5	-	-	-	2,428,326	2,428,326	2,428,326
Loans to Life Policyholders	11	-	-	-	1,510,067	1,510,067	1,510,067
Reinsurance Receivable	12	-	-	-	1,206,845	1,206,845	1,206,845
Premium Receivable	13	-	-	-	2,858,302	2,858,302	2,858,302
Other Receivables	15	-	-	-	6,684,373	6,684,373	6,684,373
Cash and Cash Equivalents	17	-	-	-	25,539,438	25,539,438	25,539,438
Total Financial Assets		5,538,347	53,125,168	26,076,867	69,539,998	154,280,380	158,034,221

As at 31st December		2014					
	Note	Fair-Value-Through-Profit-or-Loss Rs. '000	Available-For-Sale Rs. '000	Held-To-Maturity Rs. '000	Loans and Receivables Rs. '000	Carrying Value Total Rs. '000	Fair Value Total Rs. '000
Financial Liabilities Not Measured at Fair value**							
Reinsurance Creditors					1,013,511	1,013,511	1,013,511
Trade Payable	27	-	-	-	1,804,705	1,804,705	1,804,705
Bank Overdraft	28	-	-	-	599,328	599,328	599,328
Total Financial Liabilities		-	-	-	2,404,033	2,404,033	2,404,033
As at 31st December		2013					
	Note	Fair-Value-Through-Profit-or-Loss Rs. '000	Available-For-Sale Rs. '000	Held-To-Maturity Rs. '000	Loans and Receivables Rs. '000	Carrying Value Total Rs. '000	Fair Value Total Rs. '000
FINANCIAL ASSETS MEASURED AT FAIR VALUE							
Listed Shares	5	5,956,726	24,798,653	-	-	30,755,379	30,755,379
Unit Trusts	5	-	1,426,408	-	-	1,426,408	1,426,408
Listed Debentures	5	-	7,190,339	-	-	7,190,339	7,190,339
Treasury Bills and Bonds		-	5,902,342	-	-	5,902,342	5,902,342
Financial Assets Not Measured at Fair value**							
Treasury Bills and Bonds	5	-	-	19,324,293	-	19,324,293	20,708,066
Unlisted Debentures	5	-	-	-	1,890,781	1,890,781	1,886,621
Term Deposits	5	-	-	-	22,864,910	22,864,910	22,864,910
Development Bonds	5	-	-	-	5,254,857	5,254,857	5,254,857
Trust Certificates	5	-	-	-	37,481	37,481	37,481
Loans to Life Policyholders	11	-	-	-	1,578,196	1,578,196	1,578,196
Reinsurance Receivable	12	-	-	-	1,446,243	1,446,243	1,446,243
Premium Receivable	13	-	-	-	3,030,141	3,030,141	3,030,141
Other Receivables	15	-	-	-	1,222,834	1,222,834	1,222,834
Cash and Cash Equivalents	17	-	-	-	29,257,992	29,257,992	29,257,992
Total Financial Assets		5,956,726	39,317,742	19,324,293	66,583,435	131,182,196	132,561,809

As at 31st December		2013					
	Note	Fair-Value-Through-Profit-or-Loss Rs. '000	Available-For-Sale Rs. '000	Held-To-Maturity Rs. '000	Loans and Receivables Rs. '000	Carrying Value Total Rs. '000	Fair Value Total Rs. '000
Financial Liabilities Not Measured at Fair Value**							
Reinsurance Creditors					897,082	897,082	897,082
Trade Payable	27	–	–	–	2,477,590	2,477,590	2,477,590
Bank Overdraft	28	–	–	–	496,776	496,776	496,776
Total Financial Liabilities		–	–	–	3,871,448	3,871,448	3,871,448

* The fair value of quoted equity shares and unit trust are estimated based on quoted market prices.

* The fair values of financial assets Held-To-Maturity (Treasury Bills and Bonds) are estimated based on quoted market prices.

* The fair values of unlisted floating rate debentures and development bonds are estimated as equal to the carrying values.

* The fair values of unlisted fixed rate debentures are arrived at discounting the future cash flows at market yields of comparable newly issued corporate debt instruments carrying similar maturities and credit ratings.

* The fair values of commercial papers, term deposits, loans to policyholders, reinsurance receivable, premium receivable and loans to staff are estimated as equal to the carrying values as maturities do not exceed one year.

** The carrying amounts of financial assets classified as loans and receivable and financial liabilities that are not measured at fair value are reasonable approximation of fair value

41. FINANCIAL ASSETS AND LIABILITIES

41.2 FAIR VALUE HIERARCHY FOR ASSETS CARRIED AT FAIR VALUE

The following note shows an analysis of financial investments recorded at fair value by level of the fair value hierarchy.

The Group uses the following hierarchy in determining and disclosing the fair value of financial instruments by valuation techniques:

Level	Fair Value Measurement Method
Level 1	Quoted (unadjusted) prices in active markets for identical assets or liabilities.
Level 2	Techniques for which, all inputs that have a significant effect on the recorded fair value are observable, either directly or indirectly.
Level 3	Techniques, which use inputs that have a significant effect on the recorded fair value are not based on observable market data.

	Level 1	Level 2	Level 3	Total Fair Value
As at 31st December 2014	Rs. '000	Rs. '000	Rs. '000	Rs. '000
Available-For-Sale (AFS) Financial Assets				
Listed Shares	35,711,339	-	-	35,711,339
Unlisted Shares	-	-	143,257	143,257
Unit Trusts	1,146,236	-	-	1,146,236
Listed Debentures	11,880,406	-	-	11,880,406
Treasury Bonds	4,387,187	-	-	4,387,187
Total	53,125,168	-	143,257	53,268,424
Fair-Value-Through-Profit-or-Loss (FVTPL) Financial Assets				
Listed Shares	5,538,388	-	-	5,538,388
Total	5,538,388	-	-	5,538,388
Total Financial Assets	54,276,369	-	143,257	54,419,626
	Level 1	Level 2	Level 3	Total Fair Value
As at 31st December 2013	Rs. '000	Rs. '000	Rs. '000	Rs. '000
Available-For-Sale (AFS) Financial Assets				
Listed Shares	24,798,653	-	-	24,798,653
Unlisted Shares	-	-	124,480	124,480
Unit Trusts	1,426,408	-	-	1,426,408
Listed Debentures	7,190,339	-	-	7,190,339
Treasury Bills	483,700	-	-	483,700
Treasury Bonds	5,418,642	-	-	5,418,642
Total	39,317,743	-	124,480	39,442,223
Fair-Value-Through-Profit-or-Loss (FVTPL) Financial Assets				
Listed Shares	5,956,726	-	-	5,956,726
Total	5,956,726	-	-	5,956,726
Total Financial Assets	45,274,469	-	124,480	45,398,949

41.3 RECONCILIATION OF MOVEMENTS IN LEVEL 3 FINANCIAL ASSETS MEASURED AT FAIR VALUE

	As at 31st December 2013	Total Gains/ (Losses) in Income Statement	Total Gains/ (Losses) in OCI	Purchases	Sales	Transfers from Level 1 & 2	As at 31st December 2014	Total Gains/(Losses) for the Period Included in Profit or Loss for Assets held at 31st December 2013
	Rs. '000	Rs. '000	Rs. '000	Rs. '000	Rs. '000	Rs. '000	Rs. '000	Rs. '000
Available-For-Sale (AFS) Financial Assets								
Unlisted Stocks	124,480	4,298	18,777	-	-	-	143,257	23,074

	As at 31st December 2012	Total Gains/ (Losses) in Income Statement	Total Gains/ (Losses) in OCI	Purchases	Sales	Transfers from Level 1 & 2	As at 31st December 2013	Total Gains/(Losses) for the Period Included in Profit or Loss for Assets held at 31st December 2012
	Rs. '000	Rs. '000	Rs. '000	Rs. '000	Rs. '000	Rs. '000	Rs. '000	Rs. '000
Available-For-Sale (AFS) Financial Assets								
Unlisted Stocks	90,581	3,598	33,899	-	-	-	124,480	37,497

42. RELATED PARTY DISCLOSURES

42.1 TRANSACTIONS WITH KEY MANAGEMENT PERSONNEL

According to Sri Lanka Accounting Standard 24 (LKAS) – ‘Related Party Transaction’, Key Management Personnel, are those having authority and responsibility for planning, directing and controlling the activities of the entity. Accordingly, the Chairman and the Board of Directors have been classified as Key Management Personnel of the Group.

The following Directors who held office at 31st December 2014 ceased to be effective from 20th January 2015 from Sri Lanka Insurance Corporation Ltd:

Mr. H.K. Upali Dharmadasa

Mr. Piyadasa Kudabalage

Mr. H. Isuru Balapatabendi

Mr. Nayana D.P. Dehigama

Mr. S.V.R. Samarasinghe

Ms. K.M.A.N. Daulagala

The Secretary to the Treasury reconstituted the Board by appointing the following Directors with effect from 20th January 2015:

Mr. Hemaka D.S. Amarasuriya	}	Appointed with effect from 9th February 2015
Mr. T.M.R. Bangsa Jayah		
Mr. P.P.J. Perera		
Prof. L.G. Chandrasena		
Mr. H. Imal S. Fonseka		
Mr. P. Algama		

42.1.1 KEY MANAGEMENT PERSONNEL COMPENSATION

Emoluments and compensation paid to Key Management Personnel are as follows:

For the Year ended 31st December	Group		Company	
	2014 Rs. '000	2013 Rs. '000	2014 Rs. '000	2013 Rs. '000
Salaries and Short-Term Employee Benefits	119,864	142,569	21,085	27,803
Post-Employment Benefits	-	7,868	-	-
Consultation Fee	7,143	7,143	-	-
Guaranteed Payments to Directors	3,600	-	-	-

42.1.2 OTHER TRANSACTIONS WITH KEY MANAGEMENT PERSONNEL

For the Year ended 31st December	Group		Company	
	2014 Rs. '000	2013 Rs. '000	2014 Rs. '000	2013 Rs. '000
Sale of Goods and Services	-	-	-	179

42.2.1 TRANSACTIONS WITH SUBSIDIARY COMPANIES

Details of significant related party disclosures are as follows:

Name of the Company	Nature of the Relationship	Transaction	Amount Paid/Received	
			2014 Rs. '000	2013 Rs. '000
Management Services Rakshana (Pvt) Ltd.	Subsidiary	Loan granted	4,454	6,337
		Payment of Emoluments	295,904	287,187
		Advances Given	7,799	7,799
		Loans Outstanding	28,900	23,447
		Other Payables	26,216	38,069
		Investment in Equity Shares	0	0
The Lanka Hospitals Corporation PLC	Subsidiary	Investment in Equity Shares	2,925,567	2,925,567
		Insurance Premium Received	23,571	32,898
		Claims Paid	2,496	1,398
		Other Receivables	7,388	8,771
		Services	141,010	127,566
Litro Gas Lanka Ltd.	Subsidiary	Rent Charged	15,741	15,741
		Insurance Premium Received	35,063	31,744
		Claims Paid	4,621	53
		Other Receivables	22,829	37,488
		Investment in Equity Shares	3,510,063	3,510,063
Litro Gas Terminal Lanka Ltd.	Subsidiary	Insurance Premium Received	19,260	31,264
		Claims Paid	-	-
		Other Receivables	18,178	14,073
		Investment in Equity Shares	5,280,188	5,280,188
Canwill Holdings (Pvt) Ltd.	Subsidiary	Investment in Equity Shares	8,500,000	5,000,000
		Insurance Premium Received	2,928	1,968
		Claims Paid	-	-
Canowin Hotels and Spas (Pvt) Ltd.		Investment in Equity Shares	870,087	870,087
		Insurance Premium Received	885	868
		Claims Paid	-	-

42.2.2 TRANSACTIONS WITH OTHER RELATED COMPANIES

Details of significant related party disclosures are as follows:

Name of the Company	Nature of the Relationship	Transaction	Amount Paid/Received	
			2014 Rs. '000	2013 Rs. '000
Seylan Bank PLC	Affiliate	Insurance Premium Received	2,222	2,142
		Claims Paid	1,752	2,519
Ceybank Asset Management Ltd.	Affiliate	Investments in Unit Trusts	549,100	867,946
		Claims Paid	83	-
		Insurance Premium Received	2,555	2,438
		Investment in Equity Shares	99,925	83,227
Ceylon Asset Management Co. Ltd.	Affiliate	Investments in Unit Trusts	597,136	558,462
		Investments in Equity Shares	22,500	22,500

42.2.3 TRANSACTIONS OF GROUP COMPANIES**42.2.3.1 THE LANKA HOSPITALS CORPORATION PLC**

Name of the Company	Nature of the Relationship	Transaction	Amount Paid/Received	
			2014 Rs. '000	2013 Rs. '000
Lanka Hospitals Diagnostics (Pvt) Ltd.	Subsidiary	Reimbursement of Expenses and the Rent Income Receivable by the Company	3,150	-
		Services Provided to Company	125,000	-
		Share Issued	300,000	-
SRL Ltd.	Affiliate	Technical Services Provided to Lanka Hospitals Diagnostics (Pvt) Ltd.	33,230	-

42.2.3.2 LITRO GAS LANKA LTD.

Name of the Company	Nature of the Relationship	Transaction	Amount Paid/Received	
			2014 Rs. '000	2013 Rs. '000
Litro Gas Terminal Lanka (Pvt) Ltd.	Affiliate	Sale of Services		
		Reimbursement of Staff Costs	8,266	10,821,622
		Reimbursement of Costs on Other Utilities	1,476	1,534,936
		Purchase of LPG Pump	54,895	-
		Purchase of Services		
		Throughput Fee (Excluding VAT and NBT)	1,141,033	932,613
		Amounts Payable to Marine Service Provider	18,995	19,174
		Fuel for Tanks	2,108	25,919
		Other	20,339	2,601
Canwill Holdings Lanka (Pvt) Ltd.	Affiliate	Other	513	1,067
Helanco Hotels & Spa (Pvt) Ltd.	Affiliate	Other	181	-
People's Bank	Affiliate	Investments Made	579,480	2,312,458
		Trade Services	1,046,506	249,458
		Bank Charges	399	1,921
		Others	22,110	2,134

42.2.3.3 LITRO GAS TERMINAL LANKA (PVT) LTD.

Name of the Company	Nature of the Relationship	Transaction	Amount Paid/Received	
			2014 Rs. '000	2013 Rs. '000
People's Bank	Affiliate	Investments Made	173,187	806,133
		Bank Charges	81	11
		Trade	7,470	1,217

42.2.3.4 CANWILL HOLDINGS (PVT) LTD.

Name of the Company	Nature of the Relationship	Transaction	Amount Paid/Received	
			2014 Rs. '000	2013 Rs. '000
Canowin Hotels and Spas (Pvt) Ltd.	Affiliate	Staff Related Cost	2,883	-
Inreach Hotels & Spa (Pvt) Ltd.	Affiliate	Expenses Paid	279	38
Nilyan Hotels & Spa (Pvt) Ltd.	Affiliate	Expenses Paid	350	-
Helanco Hotels & Spa (Pvt) Ltd.	Subsidiary	Staff Related Cost	11,530	-
		Expenses Paid	544	659
Sinolanka Hotels & Spa (Pvt) Ltd.	Subsidiary	Staff-Related Cost	50,174	47,100

42.2.3.5 CANOWIN HOTELS AND SPAS (PVT) LTD.

Name of the Company	Nature of the Relationship	Transaction	Amount Paid/Received	
			2014 Rs. '000	2013 Rs. '000
Sinolanka Hotels & Spa (Pvt) Ltd.	Affiliate	Expenses Paid	35	35

42.2.3.6 SINOLANKA HOTELS & SPA (PVT) LTD.

Name of the Company	Nature of the Relationship	Transaction	Amount Paid/Received	
			2014 Rs. '000	2013 Rs. '000
Litro Gas Lanka Ltd.	Affiliate	Cash Settlement	20	20
Helanco Hotels & Spa (Pvt) Ltd.	Affiliate	Expenses Paid	12,186	2,470
		Cash Settlement	14,429	
Canowin Hotels and Spas (Pvt) Ltd.	Affiliate	Cash Settlement	35	50,700
Inreach Hotels & Spa (Pvt) Ltd.	Affiliate	Expenses Paid	15	-
Nilyan Hotels & Spa (Pvt) Ltd.	Affiliate	Expenses Paid	5	-

42.2.3.7 HELANCO HOTELS & SPA (PVT) LTD.

Name of the Company	Nature of the Relationship	Transaction	Amount Paid/Received
			2014 Rs. '000
Management Services Rakshana (Pvt) Ltd.	Affiliate	Staff Salaries & Allowances	1,357

43. All the transactions with Government-related entities which are significant for the users of this Annual Report are listed below:

43.1 OUTSTANDING BALANCES AS AT 31ST DECEMBER 2014

Nature of the Transaction/ Name of the Company/Entity	Bank of Ceylon	People's Bank	National Savings Bank	Regional Development Bank	People's Leasing & Finance PLC	Merchant Bank of Sri Lanka PLC
	Rs. '000	Rs. '000	Rs. '000	Rs. '000	Rs. '000	Rs. '000
Reverse Repos	15,585	-	3,631,940	-	-	-
Listed Debentures	1,377,402	-	-	-	1,664,300	106,660
Unlisted Debentures	-	-	-	-	-	-
Fixed Deposits	9,613,466	9,756,344	5,863,385	50,418	-	-
Unit Trusts	-	-	-	-	-	-
Unlisted Shares	-	-	-	-	-	-
Listed Shares	-	-	-	-	-	-
	11,006,452	9,756,344	9,495,325	50,418	1,664,300	106,660

43.2 OUTSTANDING BALANCES AS AT 31ST DECEMBER 2013

Nature of the Transaction/ Name of the Company/Entity	Bank of Ceylon	People's Bank	National Savings Bank	Regional Development Bank	People's Leasing & Finance PLC	Merchant Bank of Sri Lanka PLC
	Rs. '000	Rs. '000	Rs. '000	Rs. '000	Rs. '000	Rs. '000
Reverse Repos	49,536	-	6,480,024	-	-	-
Listed Debentures	870,726	-	-	-	123,960	148,245
Unlisted Debentures	-	-	-	-	515,375	-
Fixed Deposits	9,042,908	6,222,796	5,577,267	50,752	-	-
Unit Trusts	-	-	-	-	-	-
Unlisted Shares	-	-	-	-	-	-
Listed Shares	-	-	-	-	-	-
	9,963,169	6,222,796	12,057,291	50,752	639,335	148,245

Urban Development Authority Rs. '000	People's Merchant Finance PLC Rs. '000	Sri Lanka Telecom PLC Rs. '000	Ceybank Asset Management Ltd. Rs. '000	HDFC Bank Rs. '000	Associated Newspapers of Ceylon Ltd. Rs. '000	Lanka Cement PLC Rs. '000
-	-	-	-	-	-	-
774,833	-	-	-	119,540	-	-
-	-	-	-	-	-	-
-	-	-	-	-	-	-
-	-	-	549,100	-	-	-
-	-	-	99,925	-	5,671	-
-	38	1,000,315	-	-	-	3,415
774,833	38	1,000,315	649,025	119,540	5,671	3,415

Urban Development Authority Rs. '000	People's Merchant Finance PLC Rs. '000	Sri Lanka Telecom PLC Rs. '000	Ceybank Asset Management Ltd. Rs. '000	HDFC Bank Rs. '000	Associated Newspapers of Ceylon Ltd. Rs. '000	Lanka Cement PLC Rs. '000
-	-	-	-	-	-	-
893,808	-	-	-	103,970	-	-
-	-	-	-	-	-	-
-	-	-	-	-	-	-
-	-	-	867,946	-	-	-
-	-	-	83,227	-	4,784	-
-	17	767,600	-	-	-	3,364
893,808	17	767,600	951,174	103,970	4,784	3,364

44. MANAGEMENT OF INSURANCE, FINANCIAL AND REGULATORY RISKS

INTRODUCTION TO THE OVERVIEW

The Group is mainly exposed to the Financial Risks, Insurance Risks and Regulatory Risks. This note provides the Group's policies and procedures in measuring, managing and mitigating such risks. The Group has implemented a risk management framework and the Board of Directors has the overall responsibility for the establishment and oversight of the Group's risk management functions.

44.1 INSURANCE RISK MANAGEMENT – LIFE

44.1.1 LIFE INSURANCE CONTRACTS

The following paragraph describes the concentration of life insurance-based on the nature of the contract:

CONCENTRATION OF INSURANCE RISK

Concentration risk is defined as the risk of exposure to increased losses associated with inadequately diversified portfolios of assets or obligations. Concentration risk for a life insurer may arise with respect to investments in a geographical area, economic sector, or individual issuers, or due to a concentration of business written within a geographical area, of a policy type or of underlying risks covered.

1. From a market risk perspective, although we have invested significantly in the financial sector, our portfolio is diversified and contains huge margins.
2. From an insurance risk perspective, the main factors that would affect concentration risk include mortality risk, morbidity risk, longevity risk, policyholder behaviour risk (lapse, anti-selection) and expense risk. There is diversification across geographical regions, lines of business and even across the different insurance risk factors such that SLIC is not exposed to significant concentrations of insurance risk.

The risks associated with life insurance include -

- 'Mortality risk' is the risk that actual policyholder death experience on life insurance policies is higher than expected.
- 'Longevity risk' is the risk that annuitants live longer than expected.
- 'Morbidity risk' is the risk that policyholder health-related claims are higher than expected.
- 'Policyholders' behaviour risk' is the risk that policyholders' behavior in discontinuing and reducing contributions or withdrawing benefits prior to the maturity of the contract is worse than expected. Poor persistency rates may lead to fewer policies remaining on the books to defray future fixed expenses and reduce the future positive cash flows from the business written, potentially impacting its ability to recover deferred acquisition expenses.
- 'Expense risk' is the risk that expenses incurred in acquiring and administering policies are higher than expected.

- Market risk is the risk associated with the Group's Balance Sheet positions where the value or cash flow depends on financial markets, which is analysed in the 'Market Risk' section in the Risk Review.
- Credit risk is the risk associated with a loss or potential loss from counterparties failing to fulfil their financial obligations, which is analysed in the 'Credit Risk' section in the Risk Review.

SENSITIVITIES ANALYSIS FOR LIFE INSURANCE RISK

Provide assumptions used in determining life insurance contract liability:

Assumption	Description
Mortality	Guidelines provided by RII Act No. 43 of 2000, which are: - A67/70 for non-annuity business - a(90)m for male annuitants and (90)f for female annuitants
Investment Return	Guidelines provided by RII Act No. 43 of 2000, minimum interest used for 31st December 2013 valuation is 3.5% which is consistent with last 5 years valuation.

The total liability set-up under the above guidelines is Rs. 60,107 million excluding cost of bonus.

SLIC participated in the RBC parallel run during 2014 and results as at 31st December 2014 are as follows. The total net liability set-up under RBC guidelines for best estimated assumption is Rs. 20,905 million.

Assumption	Change in Assumption %	Impact on Liability million
Mortality	10	785
	-10	(792)
Investment Return	Up Shock Scenario under RBC	(6,009)
	Down Shock Scenario under RBC	8,837

SEGREGATION OF POLICY LIABILITY BASED ON PRODUCT CATEGORY

31st December	2014			2013		
	Insurance Liabilities (with Profits)	Insurance Liabilities (without Profits)	Total Gross Insurance Liabilities	Insurance Liabilities (with Profits)	Insurance Liabilities (without Profits)	Total Gross Insurance Liabilities
	Rs. '000	Rs. '000	Rs. '000	Rs. '000	Rs. '000	Rs. '000
Whole Life	59,752	37,203	96,955	52,740	30,909	83,649
Endowment Assurance	38,338,641	1,327,033	39,665,674	35,421,598	1,935,148	37,356,746
Term Assurance	-	1,061,883	1,061,883	-	646,181	646,181
Annuity	17,799,408	436,238	18,235,646	15,870,030	617,318	16,487,347
Rider Benefits	1,005,940	41,361	1,047,301	856,936	34,043	890,979
Total	57,203,741	2,903,718	60,107,459	52,201,303	3,263,599	55,464,902

The following table shows the participating and non-participating fund position of the Group. During the last quarter of the 2014, Group introduced 'Yasas' single premium investment policy which boosted the non-participating portfolio.

PARTICIPATING FUND VS NON-PARTICIPATING FUND

	Participating Rs. '000	Non-Participating Rs. '000	Total Rs. '000
2014	71,802,345	2,903,718	74,706,063
Percentage	96.11	3.89	
2013	63,248,008	3,263,599	66,511,606
Percentage	95.09	4.91	100.00

44.2 INSURANCE RISK MANAGEMENT - NON-LIFE

44.2.1 GENERAL INSURANCE RISK

General insurance risk includes the reasonable possibility of significant loss due to uncertainty in the frequency of the occurrence of the insured events as well as in the severity of the resulting claims.

The following provides an overview of the Group's main lines of business:

- Motor includes automobile physical damage, loss of the insured vehicle and automobile third-party liability insurance.
- Property includes fire risks (for example – fire, explosion and business interruption), natural perils (for example – earthquake, windstorm and flood), engineering lines (for example – boiler explosion, machinery breakdown and construction) and marine (cargo and hull).
- Liability includes general/public and product liability, excess and umbrella liability, professional liability including medical malpractice and errors and omissions liability.
- Special lines include Directors and officers, credit and surety, crime and fidelity, accident and health and crop.
- Worker injury includes workers compensation and employers liability.

44.2.1 The Group's underwriting strategy is to take advantage of the diversification of general insurance risks across industries and geographic regions in which the Group operates. The Group seeks to optimise shareholder value by achieving its mid-term return on equity goals. Doing so necessitates a prudent, stable underwriting philosophy that aims to take advantage of its competitive strengths while avoiding risks with disruptive volatility. At the core of the Group's underwriting is a robust governance process.

In addition to the specific risks insured, each line of business could expose the Group to losses that could arise from natural and man-made catastrophes. The main concentrations of risks arising from such potential catastrophes are regularly reported to the senior management.

The table below shows the Group's concentration of risk within the General Insurance Business by line of business based on direct written premiums before reinsurance and after reinsurance:

2014

Class	GWP Rs. '000	Reinsurance Rs. '000	NWP Rs. '000	%
Motor	7,205,255	164,882	7,040,373	71.58
Fire	1,553,151	1,394,799	158,352	1.61
Marine	402,134	280,430	121,704	1.24
Other	3,384,285	868,905	2,515,380	25.57
	12,544,825	2,709,016	9,835,809	100.00

2013

Class	GWP Rs. '000	Reinsurance Rs. '000	NWP Rs. '000	%
Motor	7,332,414	170,004	7,162,410	72.91
Fire	1,867,397	1,688,446	178,951	1.82
Marine	377,535	275,849	101,686	1.04
Other	3,375,804	995,367	2,380,437	24.23
	12,953,150	3,129,666	9,823,484	100.00

44.2.2 REINSURANCE RISK

The Group purchases reinsurance as a part of its risks mitigation programme. Reinsurance ceded is placed on both proportional and non-proportional basis. Proportional reinsurance arrangement includes both Quota Share and Facultative Treaty programmes which is taken out to reduce the overall exposure of the Group to certain classes of business. Non-proportional reinsurance programmes, which are primarily excess-of-loss reinsurance arrangements, are designed to mitigate the Group net exposure to large single and catastrophic losses. Retention limits on the excess-of-loss reinsurance programmes vary by product line.

The following table shows the credit ratings of the reinsurance companies with whom the Group has arrangements:

Name of the Company	Debit FSS Rating	Credit Rating	Rating Agency
Zurich Insurance Company – Australian	A+	A+	S & P
UNIQA Österreich Versicherungen AG	A	A	S & P
Trust International Insurance and Reinsurance	A-	A-	A.M.Best
Aviabel S.A. Brussels, Belgium	A-	A-	S & P
AXA Corporate Solutions Assurance SA, Aviation Division, Paris, France	A+	A	S & P
Generali Osiguranje d.d.	BBB+	BBB+	S & P
HDI Gerling Insurance Company Hannover, Germany	A	A+	A.M.Best
HDI – Gerling Industrie Versicherung AG,	A	A+	A.M.Best
International Insurance Company of Hannover Ltd.	A+	AA-	A.M.Best
Württembergische Versicherung AG	A-	A-	S & P
TM Tryggingamidstodin hf	BBB-	BBB-	S & P
General Insurance Corporation of India, Mumbai, India	A-	A-	A.M.Best
The New India Assurance Company Ltd., Mumbai, India	A-	A-	A.M.Best
Partner Reinsurance Europe SE, Dublin, Ireland per Zurich branch	A+	AA-	A.M.Best
Tokio Marine & Nichido Fire Insurance Co. Ltd., Tokyo, Japan	A++	AA+	A.M. Best
Malaysian Re	A-	A-	A.M.Best
African Reinsurance Corporation, Lagos, Nigeria per Mauritius branch	A-	A-	A.M.Best
Delta Lloyd Schadeverzekering N.V.	A	A	S & P
Korean Reinsurance Company, Seoul, Korea	A	A	A.M.Best
Samsung Fire & Marine Insurance Co., Ltd., Seoul, Korea	A++	AA+	A.M.Best
Allianz GCS	A++	AA-	A.M.Best
Asia Capital Reinsurance Group Pte. Ltd.	A-	A-	A.M.Best
Catlin Singapore Pte Ltd.	A	A	A.M.Best
First Capital Insurance Ltd.	A	A	A.M.Best
India International	A-	A-	S & P
Starr International Insurance Singapore Pte. Ltd.	A	A	A.M.Best
XL Insurance Co. Ltd.	A	A+	A.M.Best
Markel Syndicate Management Ltd.	A	A+	A.M.Best

Name of the Company	Debit FSS Rating	Credit Rating	Rating Agency
Sirius International Insurance Corporation (publ) Stockholm, Sweden per Zurich branch	A	A	A.M.Best
Helvetia Schweizerische Versicherungsgesellschaft AG	A	A	S & P
Zurich Insurance Company – Switzerland	A+	AA-	A.M.Best
Abu Dhabi National Insurance Company – UAE	A	A	A.M.Best
American Home Assurance Co. – Dubai	A	A	A.M.Best
Oman Insurance Co. (PSC)–Dubai, UAE	A	A	A.M.Best
Royal and Sun Alliance	A-	A-	S & P
ACE European Group Ltd., London, England	AA	AA	S & P
ACE Underwriting Agencies Ltd.	A	A+	A.M.Best
AEGIS Managing Agency Ltd.	A	A+	A.M.Best
AIG Europe Ltd.	A	A	A.M.Best
Allianz Global Corporate & Speciality SE Munich, Germany per London Branch	A+	AA-	A.M.Best
Amlin Underwriting Ltd.	A	A+	A.M.Best
Antares Managing Agency Ltd.	A	A+	A.M.Best
Ascot Underwriting Ltd.	A	A+	A.M.Best
Aspen Managing Agency Ltd.	A	A+	A.M.Best
Assicurazioni Generali S P A, Global Risk, Trieste, Italy per London branch	A	A	A.M.Best
Asta Managing Agency Ltd.	A	A+	A.M.Best
Atrium Underwriters Ltd.	A	A+	A.M.Best
AXIS Specialty Europe SE, Dublin Ireland per London branch	A+	A+	S & P
Barbican Managing Agency Ltd.	A	A+	A.M.Best
Beazley Furlonge Ltd.	A	A+	A.M.Best
Brit Syndicates Ltd.	A	A+	A.M.Best
Catlin Insurance Company (UK) Ltd., London,England	A	A	A.M.Best
Catlin Underwriting Agencies Ltd.	A	A+	A.M.Best
Chubb Managing Agent Ltd.	A	A+	A.M.Best
Global Aerospace Underwriting Managers Limited, ‘A’ London, England	A	A+	A.M.Best
Hardy (Underwriting Agencies) Ltd.	A	A+	A.M.Best
Liberty Syndicate Management Ltd.	A	A+	A.M.Best
Mitsui Sumitomo Insurance Underwriting at Lloyd's Ltd.	A	A+	A.M.Best

Name of the Company	Debit FSS Rating	Credit Rating	Rating Agency
Novae Syndicates Ltd.	A	A+	A.M.Best
QBE Underwriting Ltd.	A	A+	A.M.Best
Talbot Underwriting Ltd.	A	A+	A.M.Best
The Channel Managing Agency Ltd.	A	A+	A.M.Best
Torus Underwriting Management Ltd.	A	A+	A.M.Best
Travelers Syndicate Management Ltd.	A	A+	A.M.Best
W R Berkley Syndicate Management Ltd.	A	A+	A.M.Best
XL London Market Ltd.	A	A+	A.M.Best
Arab Insurance Group	B++	BBB+	A.M.Best
Emirates Retakaful Ltd.	B++	BBB+	A.M.Best
Saudi Reinsurance Company	BBB+	BBB+	S & P
CBL Insurance Ltd.	B+	BBB-	A.M.Best
National Insurance Trust Fund	Owned by Government of Sri Lanka		
Chaucer Syndicates Ltd.	A	A+	A.M.Best

44.3 FINANCIAL RISK MANAGEMENT

The investment activities of the Group are exposed to the financial risks which include the Credit Risks, Liquidity Risks and Market Risks. The Investment Committee of the Company is responsible in mitigating those risks and optimising investment returns.

Investment risk management is of paramount importance in current turbulent markets characterised by high volatility of asset returns, reduced diversification benefits due to high correlations and wider dispersion in market sentiments and views.

The aim of Investment Risks Management is to promptly identify, measure, manage, report and monitor risks that affect the achievement of investment objectives. This includes taking, avoiding, mitigating and adjusting the risk profile to maintain the appropriate balance among asset growth as well as income to meet the obligations of the Fund, based on prudent risk management principles within the context of applicable (IBSL) insurance regulations.

44.3.1 MARKET RISKS

Market risk is the risk of losses in positions arising from movements in market prices. This mainly impacts the stock prices being volatile in the market. Market risks comprises foreign exchange rate, interest rate and market price risks.

The Company is maintaining the maximum exposure limit for the equity in managing the investment portfolio. Further, the Company has diversified the investment portfolio into different sectors to mitigate the unsystematic risks.

	Rise of Market		Fall of Market	
	Impact on Profit	Impact on OCI	Impact on Profit	Impact on OCI
	Rs. '000	Rs. '000	Rs. '000	Rs. '000
As at 31st December 2014				
Shock Level				
5%	276,917	1,785,567	(276,917)	(1,785,567)
10%	553,835	3,571,134	(553,835)	(3,571,134)
	830,752	5,356,701	(830,752)	(5,356,701)
As at 31st December 2013				
Shock Level				
5%	297,836	1,239,933	(297,836)	(1,239,933)
10%	595,673	2,479,865	(595,673)	(2,479,865)
	893,509	3,719,798	(893,509)	(3,719,798)

44.3.2 INTEREST RATE RISKS

Interest rate risk is the risk of loss resulting from changes in interest rates, including changes in the shape of yield curves while credit spread risk describes the sensitivity of the values of assets and liabilities due to changes in the level or the volatility of credit spreads over the risk-free interest rate yield curve.

Interest rate risk is managed over each major maturity bucket and adherence to the aggregated positions with risk limits. The Investment Committee proactively managed the fixed income portfolio by strategically shifting from low-yielding investments to relatively high-yielding ones, mitigating the pressure on interest income while closely monitoring the duration mismatches.

Further the Group has adopted the following policies to mitigate the interest rate risks:

1. A considerable portion of the investments are made in risk free investments of Government Securities with adherence to the circulations issued by the IBSL in maintaining the risk-free investments.
2. A major part of the investment portfolio is made in the rated financial institutions or in rated instruments.
3. Investment Committee of the Company is making the investment decisions and approval from the Board of Directors is sought wherever necessary.

Following table summarises the exposure to the interest rate risk by the Group:

31st December 2014	100bps Upward Parallel Shift of Yield Curve		100bps Downward Parallel Shift of Yield Curve	
	Impact on Interest Income	Impact on Equity	Impact on Interest Income	Impact on Equity
	Rs. '000	Rs. '000	Rs. '000	Rs. '000
Financial Investments				
Held-To-Maturity (HTM)	-	-	-	-
Loans and Receivables (L & R)	33,158	-	(33,158)	-
Available-For-Sale (AFS)	3,481	(125,828)	(3,481)	765,548
Fair-Value-Through-Profit-or-Loss (FVTPL)	-	-	-	-
	36,639	(125,828)	(36,639)	765,548

31st December 2013	100bps Upward Parallel Shift of Yield Curve		100bps Downward Parallel Shift of Yield Curve	
	Impact on Interest Income	Impact on Equity	Impact on Interest Income	Impact on Equity
	Rs. '000	Rs. '000	Rs. '000	Rs. '000
Financial Investments				
Held-To-Maturity (HTM)	-	-	-	-
Loans and Receivables (L & R)	68,310	-	(68,310)	-
Available-For-Sale (AFS)	3,481	(325,428)	(3,481)	343,198
Fair-Value-Through-Profit-or-Loss (FVTPL)	-	-	-	-
	71,791	(325,428)	(71,791)	343,198

* In case of a shift in yield curve, there is -

No impact to the Interest Income or to the Equity for the fixed rate debt instruments classified under HTM and L&R.

An impact to the Interest Income but no impact to the Equity for the floating rate debt instruments classified under HTM and L&R.

No impact to the Interest Income but there is an impact to the Equity for the fixed rate debt instruments classified under AFS.

An impact to the Interest Income but no impact to the Equity for the floating rate debt instruments classified under AFS.

* No floating rate debt instruments have been classified under HTM as at 31st December 2014.

* No debt instruments have been classified under FVTPL as at 31st December 2014.

CARRYING AMOUNTS OF FOREIGN CURRENCY DENOMINATED FINANCIAL ASSETS

For the year ended 31st December	2014 Carrying Value Rs. '000	2013 Carrying Value Rs. '000
Development Bonds:		
USD	2,428,326	5,254,857
Fixed Deposits:		
USD	4,616,334	1,350,280
GBP	998,116	1,010,769
AUD	1,888,969	1,957,012
EUR	8,012	-
MVR	93,682	90,919
	10,033,438	9,663,837

EXCHANGE RATE SENSITIVITY

As at 31st December 2014

	Exchange Rate Shock Level		
	1.0% Rs. '000	1.5% Rs. '000	2.0% Rs. '000
Impact on Forex Gain/Loss			
USD	70,213	105,320	140,427
GBP	9,981	14,972	19,962
AUD	18,890	28,335	37,779
EUR	80	120	160
MVR	937	1,405	1,874
	100,101	150,152	200,202
Impact on Interest Income			
USD	2,130	3,195	4,260
GBP	38	56	75
AUD	80	120	161
EUR	0	0	0
MVR	28	41	55
	2,275	3,413	4,551

As at 31st December 2013	Exchange Rate Shock Level		
	1.0% Rs. '000	1.5% Rs. '000	2.0% Rs. '000
Impact on Forex Gain/Loss			
USD	65,323	97,984	130,646
GBP	10,108	15,162	20,215
AUD	19,570	29,355	39,140
EUR	-	-	-
MVR	909	1,364	1,818
	95,910	143,865	191,820
Impact on Interest Income			
USD	2,346	3,518	4,691
GBP	52	78	103
AUD	98	147	196
EUR	-	-	-
MVR	21	31	41
	2,516	3,774	5,032

MARKET RATE RISK

The Company is maintaining the maximum exposure limit for the equity in managing the investment portfolio. Further the Company has diversified the investment portfolio into different sectors to mitigate the unsystematic risks.

PORTFOLIO DIVERSIFICATION OF EQUITY RISK

SRI LANKA INSURANCE CORPORATION LTD. - LIFE INSURANCE BUSINESS

Sector	2014		2013	
	Carrying Value Rs. '000	%	Carrying Value Rs. '000	%
Bank, Finance and Insurance	22,100,123	78.09	15,052,913	69.69
Hotel and Travel	2,376,721	8.40	2,125,682	9.84
Healthcare*	1,457,914	5.15	1,457,914	6.75
Telecommunication	894,544	3.16	768,564	3.56
Construction and Engineering	693,362	2.45	682,584	3.16
Manufacturing	283,420	1.00	503,682	2.33
Diversified Holdings	154,376	0.55	399,240	1.85
Trading	151,438	0.54	122,820	0.57
Land and Property	91,321	0.32	64,238	0.30
Motors	50,578	0.18	199,739	0.92
Investment Trusts	47,926	0.17	46,705	0.22
Information Technology	263	-	526	0.00
Power and Energy	158	-	9,066	0.04
Chemicals and Pharmaceuticals	-	-	163,661	0.76
Plantation	-	-	2,534	0.01
Footwear and Textiles	-	-	875	-
Total	28,302,143	100.00	21,600,741	100.00

*Including the The Lanka Hospitals Corporation PLC which is a subsidiary of SLIC.

SRI LANKA INSURANCE CORPORATION LTD. - GENERAL INSURANCE BUSINESS

Sector	2014		2013	
	Carrying Value Rs. '000	%	Carrying Value Rs. '000	%
Bank Finance and Insurance	13,171,309	82.42	9,208,522	75.56
Healthcare*	1,575,156	9.86	1,575,156	12.92
Construction and Engineering	693,449	4.34	682,670	5.60
Manufacturing	338,416	2.12	308,595	2.53
Telecommunication	105,771	0.66	112,191	0.92
Diversified Holdings	45,997	0.29	173,487	1.42
Chemicals and Pharmaceuticals	34,485	0.22	85,132	0.70
Trading	10,316	0.06	15,798	0.13
Investment Trusts	5,558	0.03	18,249	0.15
Power and Energy	158	-	111	-
Beverages, Food and Tobacco	-	-	3,740	0.03
Motors	-	-	2,807	0.02
Hotel and Travel	-	-	1,250	0.01
Total	15,980,614	100.00	12,187,708	100.00

*Including the The Lanka Hospitals Corporation PLC which is a subsidiary of SLIC.

44.3.3 CREDIT RISKS

The credit risk is the risk of investee companies, reinsurers and other counter party defaulting to meet its contractual obligation. Accordingly, it refers to the risk that a borrower will default on any type of debt by failing to make payments which it is obligated to do. The risk is primarily that of the lender and include lost principal and interest, disruption to cash flows and increased collection costs.

The Group has established its own limits on concentration in investments by single issuers and certain asset classes and also limits investments in illiquid instruments.

No investment has been made in term deposits other than in Licensed Commercial Banks and Licensed Specialised Banks.

Investment grade credit rating for both the entity and the instrument by a recognised credit rating agency is expected for all investments in corporate debentures and commercial papers.

No debt investment has been made in any of the related companies.

A comprehensive credit analysis is carried out internally prior to making any investment in a debt security.

As at 31st December	2014 Rs. '000	% of Allocation	2013 Rs. '000	% of Allocation
Financial Investments				
Debt Securities – Loans and Receivables	19,485,506	62.54	18,659,562	72.39
Debt Securities – Available-For-Sale	11,671,181	37.46	7,116,244	27.61
	31,156,687	100.0	25,775,807	100.0

CREDIT RISK EXPOSURE - GENERAL INSURANCE BUSINESS

As at 31st December	2014 Rs. '000	% of Allocation	2013 Rs. '000	% of Allocation
Financial Investments				
Debt Securities – Loans and Receivables	9,827,141	97.92	6,133,611	98.81
Debt Securities – Available-For-Sale	209,225	2.08	74,095	1.19
	10,036,367	100.0	6,207,706	100.0

DEBT SECURITIES ALLOCATION ACCORDING TO CREDIT RATINGS
LIFE INSURANCE BUSINESS

As at 31st December Rating	2014		2013	
	Rs. million	% of Total	Rs. million	% of Total
AAA	4,454	14.16	4,258	16.90
AA+	12,968	41.22	11,666	46.31
AA	1,393	4.43	871	3.46
AA-	4,273	13.58	1,630	6.47
A+	3,157	10.03	2,441	9.69
A	206	0.65	461	1.83
A-	1,070	3.40	717	2.85
BBB+	1,515	4.82	697	2.77
BBB	307	0.97	205	0.81
BBB-	38	0.12	245	0.97
Unrated	2,078	6.60	2,002	7.95
Total	31,457	100.00	25,192	100.00

Credit Risk on Fixed Deposits is based on Credit Risk of the Bank.

GENERAL INSURANCE BUSINESS

As at 31st December	2014		2013	
	Rs. million	% of Total	Rs. million	% of Total
AAA	1,422	14.17	1,319	21.25
AA+	6,402	63.79	3,600	57.99
AA	141	1.40	12	0.20
AA-	964	9.61	487	7.84
A+	174	1.73	174	2.80
A-	733	7.30	327	5.27
BBB+	200	1.99	251	4.04
Unrated	-	-	37	0.60
Total	8,614	100.00	6,208	100.00

Credit Risk on Fixed Deposits is based on Credit Risk of the Bank.

44.3.4 THE MAXIMUM CREDIT EXPOSURE

The carrying amount of the financial assets represent the maximum credit exposure. The maximum credit exposure to credit risk at the end of the reporting period was as follows:

For the year ended 31st December	Notes	Consolidated		Company	
		2014 Rs. '000	2013 Rs. '000	2014 Rs. '000	2013 Rs. '000
Available-For-Sale	5	11,880,406	7,190,339	11,880,406	7,190,339
Loans and Receivables	5	29,312,647	24,793,173	29,312,647	24,793,173
Loans to Policyholders	11	1,510,067	1,578,196	1,512,067	1,578,196
Reinsurance Receivable	12	1,206,845	1,446,243	1,206,845	1,446,243
Premium Receivable from Policyholders	13.1	2,858,302	3,030,141	2,858,302	3,030,141
Premium Receivable from Agents, Brokers and Intermediaries	13.2	-	-	-	-
Other Receivables	15	6,684,328	1,222,834	3,577,063	1,222,834
		51,942,528	37,682,730	51,942,528	37,682,730

LIQUIDITY RISK

The risk of the Company being unable to meet obligations due to inadequate availability of liquid assets is referred to as liquidity risk.

The table below summarises the maturity profile of the financial investments of the Company based on remaining contractual obligations, including interest payable and receivable:

Maturity Analysis

Company	Carrying Value	Up to 1 Year	1 to 2 Years	2 to 5 Years	5 to 10 Years	Over 10 Years	Total
As at 31st December 2014	Rs. '000	Rs. '000	Rs. '000	Rs. '000	Rs. '000	Rs. '000	Rs. '000
Financial Investments							
Held-To-Maturity							
(HTM) Financial Assets	26,076,867	1,150,000	400,000	15,936,230	2,000,000	6,900,000	26,386,230
Loans and Receivables							
(L&R) Financial Assets	31,740,973	34,997,660	525,000	455,000	-	-	35,977,660
Available-For-Sale (AFS)							
Financial Assets	53,268,424	2,321,480	1,584,548	9,649,987	2,935,191	-	16,491,206
Fair-Value-Through-Profit-or-Loss (FVTPL)							
Financial Assets	5,538,347	-	-	-	-	-	-
	116,624,612	38,469,140	2,509,548	26,041,217	4,935,191	6,900,000	78,855,096

Company	Carrying Value	Up to 1 Year	1 to 2 Years	2 to 5 Years	5 to 10 Years	Over 10 Years	Total
As at 31st December 2013	Rs. '000	Rs. '000	Rs. '000	Rs. '000	Rs. '000	Rs. '000	Rs. '000
Financial Investments							
Held-To-Maturity							
(HTM) Financial Assets	19,324,293	900,000	650,000	15,336,230	3,385,000	2,400,000	22,671,230
Loans and Receivables							
(L&R) Financial Assets	30,048,030	26,145,623	2,735,000	525,000	-	-	29,405,623
Available-For-Sale (AFS)							
Financial Assets	39,442,223	1,840,000	2,321,480	6,925,865	1,572,397	1,362,794	14,022,536
Fair-Value-Through-Profit-or-Loss (FVTPL)							
Financial Assets	5,956,726	-	-	-	-	-	-
	94,771,272	28,885,623	5,706,480	22,787,095	4,957,397	3,762,794	66,099,389

45. COMMITMENTS, CONTINGENCIES AND GUARANTEES

45.1 COMMITMENTS

The Group does not have significant capital commitments as at the reporting date other than described below:

(A) LITRO GAS LANKA LTD.

There were capital commitments of Rs. 250,907,700/- for new empty cylinders: Mabima tank requalification, tank for Volvo bowser and highway filling station.

(B) LITRO GAS TERMINAL LANKA (PVT) LTD.

Financial commitments:

- (i) Litro Gas Terminal Lanka (Pvt) Ltd. has an annual commitment to pay Rs. 16,843,750/- (excluding taxes) as lease rental for the use of land.
- (ii) Litro Gas Terminal Lanka (Pvt) Ltd. has paid Rs. 30,720,225/- (excluding taxes) as lease rental for the use of storage facility at Hambanthota Port as year one rental.

Litro Gas Terminal Lanka (Pvt) Ltd. has capital commitments of Rs. 20,935,460/- at the reporting date.

(C) THE LANKA HOSPITALS CORPORATION PLC

Commitment on Land Lease

The Lanka Hospitals Corporation PLC has entered into a 99-year lease agreement with the Urban Development Authority. In terms of this agreement, annual lease premiums payable are as follows:

Year	Annual Lease Premiums Rs. '000
1999 to 2003	9,273 (Excluding Taxes)
2004 to 2025	18,547 (Excluding Taxes)
2026	9,273 (Excluding Taxes)

Premiums paid on each installment is carried forward and amortised over the 99-year period, in accordance with the said agreement.

From the year 2027, Rs. 7,000/- per annum is payable as nominal ground rent for 5-years. Thereafter, the said ground rent will be revised every 5 years on the basis of an annual increase no greater than the average weighted deposit rate published by the Central Bank of Sri Lanka prevailing at the end of each year or 10% per annum whichever is lower.

The future aggregate minimum lease payments under non-cancellable operating lease by 2026 are as follows:

	2014 Rs. '000	2013 Rs. '000
Not Later than 1 Year	18,546	185,467
Later than 1 Year and not Later than 5 Years	74,186	74,186
Later than 5 Years	120,552	139,099
	213,284	398,752

	2014 Rs. '000	2013 Rs. '000
--	------------------	------------------

(D) APPROXIMATE AMOUNT CONTRACTED FOR BUT NOT INCURRED

Sinolanka Hotels & Spa (Pvt) Ltd.	4,299,627	4,624,912
Helanco Hotels & Spa (Pvt) Ltd.	462,777	-
The Lanka Hospitals Corporation PLC	43,000	-

45.2 CONTINGENT LIABILITIES AND GUARANTEES

There were no significant contingent liabilities and guarantees which no provision has been made in the accounts or approved by the Board but not contracted as at the reporting date that would require adjustments to or disclosure in the Financial Statements, other than described below:

45.2.1 CONTINGENT LIABILITIES

VALUE ADDED TAX ASSESSMENTS ISSUED BY THE COMMISSIONER GENERAL OF INLAND REVENUE

In 2006, the Commissioner General of Inland Revenue has issued Value Added Tax Assessments on Reinsurance claims received from foreign reinsurers, for the years of assessments 2004/05 and 2005/06 amounting to Rs. 318,099,913/- and Rs. 26,903,739/- respectively.

The Company has filed valid appeals against these assessments. The Board of Review by the letter dated 21st July 2010 determined that the assessments are valid. The Company has made an appeal to the Court of Appeal contesting the determination made by the Board of Review. The Company has provided the Liability of Rs. 345 million pending the decision of the Court of Appeal.

On 2nd April 2013, the Commissioner General of Inland Revenue has issued a Value Added Tax Assessments on Financial Services for the Taxable Periods from 1st January 2010 to 31st December 2010 amounting to Rs. 2,363 million. The Company has already made valid appeals against the assessments by the letter dated 3rd May 2013. Appeals have been lodged against the assessments issued on incorrect reasons; and the Commissioner General has determined the above liability as valid on 10th April 2015 and informed on 5th May 2015. The Company has notified to the Tax Appeal Commission of the intention of preferring an appeal to the Commission against the determination of the Commissioner General on 13th May 2015.

INCOME TAXES

On 28th November 2014 the Commissioner General of Inland Revenue has issued an Assessment on Income Tax for Life Insurance for the year of Assessment 2011/12 amounting to Rs. 524 million. Company has already made valid appeal against the assessment by our letter dated 24th December 2014 have been lodged against the assessment issued on incorrect reasons.

45.2.2 GUARANTEES

LITRO GAS TERMINAL LANKA (PVT) LTD.

OPERATING LEASE WITH LAND RECLAMATION BOARD

According to LKAS 17, the Standard requires lease payments under an operating lease to be recognised as an expense on a straight-line basis over the lease term unless another systematic basis is more representative of the time pattern of the user's benefit. Litro Gas Terminal Lanka (Pvt) Ltd. has an operating lease arrangement with Land Reclamation Board where the lease term is 50 years and the rental increases by 175% in every five years. However, the Litro Gas Terminal Lanka (Pvt) Ltd., does not recognise the said lease on a straight-line basis since the Directors are of the view that this represents a more systematic basis of the time pattern of the benefit.

46. EVENTS AFTER THE REPORTING DATE

There were no significant events after the reporting date other than disclosed below:

46.1 SUPER GAIN TAX

The interim budget proposal presented by the Minister of Finance on 29th January 2015 and the pursuant bill gazette on 30th March 2015, imposed a one-off tax of 25% on taxable profits for the year of assessment 2013/14 on any company or each company in a group of companies, if the Company's profit before income tax exceeds Rs. 2,000 million. In the absence of applicability and measurement criteria for the computation of this tax at the time of publishing these Financial Statements, the Company is not in a position to assess the impact of this one-off tax on these financials for the year ended 31st December 2014 and therefore no provision has been made on account of the said tax in these Financial Statements.

CHANGE IN BOARD OF DIRECTORS

The following Directors who held office at 31st December 2014 ceased to be effective with effect from 20th January 2015 from Sri Lanka Insurance Corporation Ltd.:

Mr. H.K. Upali Dharmadasa

Mr. Piyadasa Kudabalage

Mr. H. Isuru Balapatabendi

Mr. Nayana D.P. Dehigama

Mr. S.V.R. Samarasinghe

Ms. K.M.A.N. Daulugala

The Secretary to the Treasury reconstituted the Board by appointing the following Directors:

Mr. Hemaka D.S. Amarasuriya (9th February 2015)

Mr. T.M.R. Bangsa Jayah (9th February 2015)

Mr. P.P.J. Perera (9th February 2015)

Prof. L.G. Chandrasena (20th January 2015)

Mr. H. Imal S. Fonseka (20th January 2015)

Mr. P. Algama (20th January 2015)

47. THE SEGREGATION OF THE LIFE AND GENERAL INSURANCE BUSINESS

As stipulated in the Amendment to the Insurance Act No. 03 of 2011, composite insurance companies are required to segregate the long-term insurance business and the general insurance business carried on by it, into two separately established companies and the said compliance was to be effective by 11th February 2015. The Company is currently discussing with the Ministry of Finance to agree a methodology to satisfy the legal framework. Since the Company has not been able to segregate the composite business due to the aforementioned facts, the disclosure requirements of the 'Guidelines on the presentation and disclosure of the long-term and general business under Section 53 of the Regulation of Insurance Industry (Amendment) Act No. 3 of 2011 issued by The Institute of Chartered Accountants of Sri Lanka' are not applicable.

48. USE OF TERMINAL FACILITY BY LITRO GAS LANKA LTD.

Litro Gas Lanka Ltd. obtains bulk storage facilities of LPG from Litro Terminal Lanka (Pvt) Ltd. In obtaining this services, the Company uses the latter's own storage tanks, pipelines and pumping stations and pays a 'throughput fee' to Litro Terminal for the facilities obtained. This throughput arrangement contains a lease arrangement identified under IFRIC 4 and, thus, constitute a finance lease arrangement as per the terms of the contract. However, in view of the storage facility of the terminal being available for other importers as well as the management's intention to enter into contracts with other importers to store the LPG, the said storage facilities have not been recognised in the books of account of the Company. However, during the year under review Litro Terminal had not entered into an agreement to lease out the facilities in absence of any favourable proposal from the prospective importers.

49. PRINCIPLE SUBSIDIARIES AND SUB-SUBSIDIARIES

Company	Principal Activities	Class of Shares Held	Proportion of Class Held %	Group Interest %	Non-Controlling Interest %
The Lanka Hospitals Corporation PLC	Healthcare and Laboratory Services	Ordinary	54.61	54.61	45.39
Lanka Hospitals Diagnostics (Pvt) Ltd.	Healthcare and Laboratory Services	Ordinary	100.00	54.61	45.39
Litro Gas Lanka Ltd.	Import, Process, Store, Distribute and Sell Liquid Petroleum Gas (LPG) and Provide Other Incidental Services	Ordinary	100.00	100.00	0.00
Litro Gas Terminal Lanka (Pvt) Ltd.	Provide Bulk Storage Facilities for Liquid Petroleum Gas	Ordinary	100.00	100.00	0.00
Canowin Hotels and Spas (Pvt) Ltd	Hoteliering	Ordinary	100.00	100.00	0.00
Canwill Holdings (Pvt) Ltd.	Investment Promotion in Relation to Leisure Sector	Ordinary	72.97	72.97	27.03
Sinolanka Hotels & Spa (Pvt) Ltd.	Hoteliering	Ordinary	100.00	72.97	27.03
Helanco Hotels & Spa (Pvt) Ltd.	Hoteliering	Ordinary	100.00	72.97	27.03
Management Services Rakshana (Pvt) Ltd.	Management Services	Ordinary	100.00	100.00	0.00

50. NON-CONTROLLING INTEREST

The Group has not identified any non controlling interest which is material to the Group on qualitative and quantitative basis.

ACQUISITION OF NON-CONTROLLING INTEREST

In March 2014, the Group increased its shareholding in Canwill Holdings (Pvt) Ltd. and its subsidiaries [Sinolanka Hotels & Spa (Pvt) Ltd. and Helanco Hotels & Spa (Pvt) Ltd.] from 58.33% to 72.97% [representing a increase in shares held to 350,000,000 of Canwill Holdings (Pvt) Ltd.].

8.0
Supplementary Information

*ADDITIONAL INFORMATION
THAT IS SUPPORTIVE OF THE
CHAPTERS FOUND ELSEWHERE
IN THE REPORT*

8.1.0 STATEMENT OF FINANCIAL POSITION OF THE LIFE INSURANCE

As at 31st December	Note	2014 Rs.	2013 Rs.
Assets			
Financial Investments	A	91,456,550	73,643,020
Investment in Subsidiaries	B	1,457,914	1,457,914
Loans to Life Policyholders	C	1,510,067	1,578,196
Premium Receivable		270,208	327,754
Reinsurance Receivable		29,080	39,978
Deferred Tax Assets		86,630	56,469
Other Assets	D	1,606,799	2,373,771
Property, Plant & Equipment	E	42,172	55,969
Cash and Cash Equivalents		2,638,102	6,663,628
Total Assets		99,097,521	86,196,699
Equity and Liabilities			
Equity			
Revaluation Reserve		27,877	40,892
Available-For-Sale Reserve	F	17,493,276	10,272,074
Revenue Reserves	G	4,434,340	4,570,968
Policyholder Reserve Fund	H	(3,328,929)	(510,888)
		18,626,565	14,373,045
Liabilities			
Insurance Contract Liabilities - Life	I	77,254,498	69,079,061
Reinsurance Payable		-	18,467
Employee Benefits		319,660	221,490
Current Tax Liabilities		800,664	852,393
Other Liabilities	J	1,925,815	1,523,134
Financial Liabilities		170,319	129,109
Total Liabilities		80,470,956	71,823,654
Total Equity and Liabilities		99,097,521	86,196,699

8.2.0 NOTES TO THE FINANCIAL STATEMENTS - LIFE INSURANCE FUND

	Note	2014		2013	
		Carrying Value Rs. '000	Fair Value Rs. '000	Carrying Value Rs. '000	Fair Value Rs. '000
A. FINANCIAL INVESTMENTS					
Held-To-Maturity (HTM)	A.1	26,029,372	29,781,688	18,746,003	20,123,228
Loans and Receivables (L & R)	A.2	21,697,982	21,695,721	20,626,183	20,622,023
Available-For-Sale (AFS)	A.3	38,606,810	38,606,810	28,886,521	28,886,521
Fair-Value-Through-Profit-or-Loss (FVTPL)	A.4	5,122,386	5,122,386	5,384,313	5,384,313
		91,456,550	95,206,605	73,643,020	75,016,084

A.1 HELD-TO-MATURITY (HTM)

Treasury Bills		487,576	490,450	-	-
Treasury Bonds		25,541,796	29,291,238	18,746,003	20,123,228
		26,029,372	29,781,688	18,746,003	20,123,228

A.2 LOANS AND RECEIVABLES (L & R)

Unlisted Debentures	A.2.1	1,067,143	1,064,882	1,590,689	1,586,528
Fixed Deposits		18,418,363	18,418,363	17,068,873	17,068,873
Development Bonds		2,212,476	2,212,476	1,966,621	1,966,621
		21,697,982	21,695,721	20,626,183	20,622,023

	Maturity Date	2014			2013			
		Face Value Rs. '000	Carrying Value Rs. '000	Fair Value Rs. '000	Maturity Date	Face Value Rs. '000	Carrying Value Rs. '000	Fair Value Rs. '000
A.2.1 UNLISTED DEBENTURES								
Commercial Bank of Ceylon PLC	15.05.2016	125,000	141,608	134,834	15.05.2016	125,000	141,608	131,784
People's Leasing & Finance PLC	-	-	-	-	26.04.2014	500,000	515,375	515,375
Singer Sri Lanka PLC	30.04.2015	250,000	254,040	254,040	30.04.2015	250,000	255,327	255,327
Central Finance PLC	24.05.2015	500,000	521,138	521,138	24.05.2015	500,000	528,015	528,015
Siyapatha Finance PLC	17.12.2015	50,000	50,336	54,848	17.12.2015	50,000	50,336	55,999
National Development Bank PLC	30.06.2016	100,000	100,021	100,021	30.06.2016	100,000	100,028	100,028
		1,025,000	1,067,143	1,064,882		1,525,000	1,590,689	1,586,528

	Note	2014		2013	
		Carrying Value Rs. '000	Fair Value Rs. '000	Carrying Value Rs. '000	Fair Value Rs. '000
A.3 AVAILABLE-FOR-SALE (AFS)					
Listed Stocks	A.3.1	21,721,843	21,721,843	14,758,515	14,758,515
Unit Trusts	A.3.2	900,350	900,350	1,209,103	1,209,103
Listed Debentures	A.3.3	11,671,181	11,671,181	7,116,244	7,116,244
Treasury Bills		-	-	483,700	483,700
Treasury Bonds		4,313,436	4,313,436	5,318,958	5,318,958
		38,606,810	38,606,810	28,886,521	28,886,521

	No. of Shares	2014		No. of Shares	2013	
		Carrying Value Rs. '000	Fair Value Rs. '000		Face Value Rs. '000	Carrying Value Rs. '000
A.3.1 LISTED STOCKS						
Bank, Finance and Insurance						
Commercial Bank of Ceylon PLC	40,851,867	6,985,669	6,985,669	40,219,594	4,870,593	4,870,593
DFCC Bank PLC	26,509,832	5,805,653	5,805,653	26,509,832	3,433,023	3,433,023
Seylan Bank PLC	8,798,869	835,893	835,893	8,798,869	571,047	571,047
Hatton National Bank PLC	31,503,954	6,143,271	6,143,271	31,503,954	4,631,081	4,631,081
National Development Bank PLC	7,805,426	1,951,357	1,951,357	7,805,426	1,252,771	1,252,771
		21,721,843	21,721,843		14,758,515	14,758,515

A.3.2 UNIT TRUSTS

Ceybank Unit Trust	17,000,000	549,100	549,100	33,035,291	852,641	852,641
Ceylon Income Fund	25,000,000	351,250	351,250	27,004,714	356,462	356,462
		900,350	900,350		1,209,103	1,209,103

As at 31st December	2014				2013			
	Maturity Date	Face Value Rs. '000	Carrying Value Rs. '000	Fair Value Rs. '000	Maturity Date	Face Value Rs. '000	Carrying Value Rs. '000	Fair Value Rs. '000
A.3.3 LISTED DEBENTURES								
Banks, Finance and Insurance								
Bank of Ceylon	29.11.2017	500,000	507,014	507,014	29.11.2017	500,000	507,014	507,014
Bank of Ceylon	24.10.2018	287,970	294,944	294,944	24.10.2018	287,970	294,944	294,944
Bank of Ceylon	21.09.2019	500,000	510,768	510,768	-	-	-	-
Bank of Ceylon	24.10.2023	67,050	80,381	80,381	24.10.2023	67,050	68,768	68,768
Hatton National Bank PLC	12.06.2018	316,717	341,256	341,256	12.06.2018	316,717	341,256	341,256
Hatton National Bank PLC	14.12.2019	500,000	501,805	501,805	-	-	-	-
Hatton National Bank PLC	31.03.2021	478,459	249,130	249,130	31.03.2021	478,459	224,437	224,437
Hatton National Bank PLC	30.08.2023	126,888	92,435	92,435	30.08.2023	126,888	90,506	90,506
Hatton National Bank PLC	31.03.2024	1,362,794	508,121	508,121	31.03.2024	1,362,794	456,742	456,742
Commercial Bank of Ceylon PLC	18.12.2016	250,000	285,032	285,032	18.12.2016	250,000	285,032	285,032
National Development Bank PLC	19.12.2023	750,000	984,600	984,600	19.12.2023	750,000	753,713	753,713
Seylan Bank PLC	21.02.2018	449,520	473,905	473,905	21.02.2018	449,520	473,905	473,905
Seylan Bank PLC	22.12.2019	500,000	501,060	501,060	-	-	-	-
Sampath Bank PLC	11.10.2017	36,600	45,201	45,201	11.10.2017	36,600	45,201	45,201
Sampath Bank PLC	04.12.2018	340,190	362,484	362,484	04.12.2018	340,190	343,583	343,583
Sampath Bank PLC	14.12.2019	500,000	501,886	501,886	-	-	-	-
Nations Trust Bank PLC	04.08.2016	200,000	209,041	209,041	04.08.2016	200,000	209,041	209,041
DFCC Vardhana Bank PLC	07.09.2016	74,074	74,090	74,090	07.09.2016	74,074	74,095	74,095
Pan Asia Banking Corporation PLC	18.03.2017	200,000	205,647	205,647	18.03.2017	200,000	207,784	207,784
The Housing Development Finance Corporation Bank of Sri Lanka	23.10.2018	100,000	122,470	122,470	23.10.2018	100,000	103,970	103,970
Merchant Bank of Sri Lanka PLC	-	-	-	-	15.11.2014	140,000	148,245	148,245
Merchant Bank of Sri Lanka PLC	11.12.2019	113,520	114,892	114,892	-	-	-	-
People's Leasing & Finance PLC	23.09.2017	750,000	767,800	767,800	-	-	-	-
People's Leasing & Finance PLC	26.03.2018	105,900	135,863	135,863	26.03.2018	105,900	123,960	123,960
People's Leasing & Finance PLC	23.09.2018	750,000	769,580	769,580	-	-	-	-
LB Finance PLC	28.11.2018	220,670	236,800	236,800	28.11.2018	220,670	223,563	223,563
Lanka ORIX Leasing Company PLC	30.06.2015	100,000	105,846	105,846	30.06.2015	100,000	105,846	105,846
Senkadagala Finance PLC	10.12.2018	100,000	100,853	100,853	10.12.2018	100,000	100,863	100,863
Citizens Development Business Finance PLC	19.12.2018	37,350	37,556	37,556	19.12.2018	37,350	37,556	37,556
Softlogic Finance PLC*	29.08.2019	12,600	13,061	13,061	-	-	-	-

* Guaranteed by Guarant Co. Ltd. which is ultimately owned by multilateral G10 governments.

As at 31st December	2014				2013			
	Maturity Date	Face Value Rs. '000	Carrying Value Rs. '000	Fair Value Rs. '000	Maturity Date	Face Value Rs. '000	Carrying Value Rs. '000	Fair Value Rs. '000
Diversified Holdings								
Hayleys PLC	09.07.2016	80,800	83,702	83,702	09.07.2016	80,800	80,800	80,800
Hemas Holdings PLC	29.04.2019	119,970	125,900	125,900	-	-	-	-
Richard Pieris and Company PLC	16.05.2017	29,580	30,739	30,739	-	-	-	-
Healthcare								
Nawaloka Hospitals PLC	30.09.2021	150,000	155,425	155,425	30.09.2021	150,000	155,484	155,484
Trading								
Abans PLC	20.12.2018	400,000	481,798	481,798	20.12.2018	400,000	401,907	401,907
Beverages, Food and Tobacco								
The Lion Brewery Ceylon PLC	17.06.2016	105,600	109,193	109,193	17.06.2016	105,600	109,193	109,193
The Lion Brewery Ceylon PLC	17.06.2017	105,600	109,260	109,260	17.06.2017	105,600	109,260	109,260
The Lion Brewery Ceylon PLC	17.06.2018	140,800	145,769	145,769	17.06.2018	140,800	145,769	145,769
The Lion Brewery Ceylon PLC	08.12.2019	400,000	402,065	402,065	-	-	-	-
Land and Property								
Urban Development Authority*	05.10.2015	871,480	893,808	893,808	05.10.2015	871,480	893,808	893,808
		12,134,132	11,671,181	11,671,181		8,098,462	7,116,244	7,116,244

* Treasury Guaranteed.

	Note	2014		2013	
		Carrying Value Rs. '000	Fair Value Rs. '000	Carrying Value Rs. '000	Fair Value Rs. '000

A.4 FAIR-VALUE-THROUGH PROFIT-OR-LOSS (FVTPL)

Listed Stocks	A.4.1	5,122,386	5,122,386	5,384,313	5,384,313
		5,122,386	5,122,386	5,384,313	5,384,313

FVTPL Investments and AFS Investments are valued at fair value. HTM and L&R Investments are valued at amortised cost.

	2014			2013		
	No. of Shares	Carrying Value Rs. '000	Fair Value Rs. '000	No. of Shares	Carrying Value Rs. '000	Fair Value Rs. '000
A.4.1 LISTED STOCKS						
Bank, Finance and Insurance						
Sampath Bank PLC	287,487	67,559	67,559	387,487	66,609	66,609
Seylan Bank PLC (NV)	-	-	-	359,000	11,057	11,057
Pan Asia Banking Corporation PLC	-	-	-	1,394,666	21,617	21,617
LB Finance PLC	1,842,900	305,921	305,921	1,842,900	188,160	188,160
Nation Lanka Finance PLC	979,500	4,800	4,800	979,500	6,954	6,954
Investment Trusts						
Renuka Holdings PLC	1,526,316	47,926	47,926	1,526,316	46,705	46,705
Diversified Holdings						
Hemas Holdings PLC	-	-	-	5,160,700	175,464	175,464
John Keells Holdings PLC	611,176	152,794	152,794	611,176	137,515	137,515
Vallibel One PLC	65,900	1,582	1,582	65,900	1,081	1,081
Colombo Fort Land & Building PLC	-	-	-	3,020,600	85,181	85,181
Footwear and Textiles						
Hayleys MGT Knitting Mills PLC	-	-	-	78,800	875	875
Hotel and Travel						
Aitken Spence Hotel Holdings PLC	5,518,727	435,979	435,979	7,268,727	543,701	543,701
Asian Hotels & Properties PLC	10,055,900	688,829	688,829	10,055,900	653,634	653,634
John Keells Hotels PLC	71,622,800	1,231,912	1,231,912	72,747,800	909,348	909,348
Anilana Hotels & Properties Ltd.	2,500,000	20,000	20,000	2,500,000	19,000	19,000
Manufacturing						
Sierra Cables PLC	-	-	-	800	1	1
Lanka Cement PLC	509,700	3,415	3,415	509,700	3,364	3,364
ACL Cables PLC	558,557	42,618	42,618	2,100,200	136,513	136,513
Tokyo Cement Company (Lanka) PLC	-	-	-	2,013,412	57,382	57,382
Tokyo Cement Company (Lanka) PLC (NV)	-	-	-	3,207,320	75,372	75,372
Royal Ceramics PLC	1,353,186	158,323	158,323	2,183,279	187,762	187,762
Lanka Walltiles PLC	807,600	79,064	79,064	807,600	43,287	43,287

	2014			2013		
	No. of Shares	Carrying Value Rs. '000	Fair Value Rs. '000	No. of Shares	Carrying Value Rs. '000	Fair Value Rs. '000
Trading						
Brown & Company PLC	906,990	97,048	97,048	906,990	77,094	77,094
TESS Agro PLC	33,993,806	54,390	54,390	35,173,600	45,726	45,726
Motors						
C M Holdings PLC	392,076	50,578	50,578	571,428	48,000	48,000
Diesel & Motor Engineering PLC	-	-	-	315,466	151,739	151,739
Telecommunications						
Dialog Axiata PLC	-	-	-	12,572,823	113,155	113,155
Sri Lanka Telecom PLC	17,713,735	894,544	894,544	17,713,735	655,408	655,408
Plantations						
Talawakelle Tea Estates PLC	-	-	-	105,600	2,534	2,534
Power and Energy						
Lanka IOC PLC	-	-	-	271,362	8,955	8,955
Laugfs Gas PLC	3,900	158	158	3,900	111	111
Information Technology						
PC House PLC	876,700	263	263	876,700	526	526
Chemicals and Pharmaceuticals						
CIC Holdings PLC	-	-	-	3,409,594	163,661	163,661
Land and Property						
Overseas Reality (Ceylon) PLC	3,472,300	91,321	91,321	3,472,300	64,238	64,238
Construction and Engineering						
Colombo Dockyard PLC	3,592,548	693,362	693,362	3,592,548	682,584	682,584
		5,122,386	5,122,386		5,384,313	5,384,313

	2014 Rs. '000	2013 Rs. '000
--	------------------	------------------

B. INVESTMENTS IN SUBSIDIARIES

	1,457,914	1,457,914
--	------------------	-----------

	Note	2014		2013	
		Carrying Value Rs. '000	Fair Value Rs. '000	Carrying Value Rs. '000	Fair Value Rs. '000

AT COST

Listed Subsidiaries	B.1	1,457,914	3,172,673	1,457,914	2,676,943
		1,457,914	3,172,673	1,457,914	2,676,943

	2014		2013	
	No. of Share	Carrying Value Rs. '000	No. of Share	Carrying Value Rs. '000

B.1 LISTED SUBSIDIARIES

The Lanka Hospitals Corporation PLC	66,097,350	1,457,914	66,097,350	1,457,914
		1,457,914		1,457,914

	2014 Rs.	2013 Rs.
--	-------------	-------------

C. LOANS TO LIFE POLICYHOLDERS

Policyholder Loans	1,510,067	1,578,196
	1,510,067	1,578,196

D. OTHER ASSETS

Inventories	10,743	10,573
Other Debtors and Receivables	662,905	1,131,210
Other Loans	773,391	734,994
Investment Receivables	-	-
Amount Due from General Division	-	275,611
Prepaid Benefit on Loans	159,759	221,383
	1,606,799	2,373,771

E. PROPERTY, PLANT AND EQUIPMENT

	Land Rs. '000	Building Rs. '000	Equipment Rs. '000	Furniture & Fittings Rs. '000	Generator Rs. '000	Electrical Fixtures Rs. '000	Others Rs. '000	Total Rs. '000
Cost								
Balance as at 01.01.2014	36,153	20,859	218,077	50,361	8,681	9,376	87	343,595
Additions	-	-	-	-	-	-	-	-
Revaluation	(4,250)	(10,590)	-	-	-	-	-	(14,840)
Balance as at 31.12.2014	31,903	10,269	218,077	50,361	8,681	9,376	87	328,755
Depreciation								
Balance as at 01.01.2014	-	1,043	218,077	50,361	8,681	9,376	87	287,625
Depreciation charge for the period	-	1,043	-	-	-	-	-	1,043
Transferred to Revaluation Reserve		(2,086)						(2,086)
Balance as at 31.12.2014	-	-	218,077	50,361	8,681	9,376	87	286,582
Carrying Amount								
As at 31st December 2013	31,903	10,269	-	-	-	-	-	42,172

F. AVAILABLE-FOR-SALE RESERVE

Life Policyholders are entitled to Rs. 8,692,622,741/- and Shareholders are entitled for Rs. 1,579,451,199/- respectively.

	2014 Rs.	2013 Rs.
G. REVENUE RESERVE		
General Reserve	42,101	42,101
Reserve on Actuarial Gain/(Loss) on Retirement Benefit	(58,424)	-
Surplus from Life Insurance (Note G.1)	4,450,664	4,528,867
	4,434,340	4,570,968

G.1 SURPLUS FROM LIFE INSURANCE

Balance as at 1st January	4,528,867	8,268,739
Surplus Attributable to Shareholders from Life Insurance	1,612,402	1,721,809
Other Comprehensive Income for the Year	-	-
Transferred to Shareholders	(1,690,605)	(5,461,681)
Balance as at 31st December	4,450,664	4,528,867

	2014 Rs.	2013 Rs.
H. POLICYHOLDER RESERVE FUND		
Balance as at 1st January	(510,888)	806,271
Change in Fair Value Measurements Applicable to Life Contract Liability	(2,818,040)	(1,317,160)
Balance as at 31st December	(3,328,929)	(510,888)
I. INSURANCE CONTRACT LIABILITIES - LIFE		
Life Assurance Fund	66,511,608	60,084,899
Movement of the Fund	6,988,818	6,831,358
Other Comprehensive Income for the Year	-	-
Transferred from Life Policyholders Reserve Fund	2,818,040	1,317,160
Transfers of Surplus from Long-Term Insurance Business	(1,612,402)	(1,721,809)
	74,706,065	66,511,608
Policyholder Outstanding claims	2,548,432	2,567,453
	77,254,498	69,079,061
J. OTHER LIABILITIES		
Agency Commission Payable	166,251	134,690
Premium Received in Advance	373,422	241,263
Amount Due to General Division	92,630	-
Trade Creditors and Accrued Expenses	1,293,512	1,147,181
	1,925,815	1,523,134

8.3.0 TEN YEAR SUMMARY

8.3.1 STATEMENT OF INCOME

	2014 Rs. '000	SLFRSs/LKASs		
		2013 Rs. '000	2012 Restated Rs. '000	2011 Restated Rs. '000
Non-Life				
Gross Written Premium	12,544,828	12,953,151	12,803,592	11,477,600
Net Earned Premiums	9,820,149	9,504,974	9,487,217	7,828,645
Net Claims Incurred	(6,205,796)	(4,934,074)	(6,194,011)	(4,970,962)
Operating and Administration Expenses	(3,977,372)	(2,851,002)	(2,008,724)	(2,129,682)
Investment and Other Income	2,224,733	2,516,799	2,064,835	(245,498)
Profit before Taxation	1,861,713	3,736,069	2,829,411	158,513
Taxation	(217,101)	(803,033)	(900,971)	(407,432)
Profit after Taxation	1,644,613	2,933,035	1,928,440	(248,919)
Long Term				
Gross Written Premium	8,121,159	8,397,718	7,369,032	6,743,073
Net Written Premium	7,984,758	8,300,082	7,281,225	6,593,457
Investment and Other Income	9,272,341	7,658,997	6,811,040	3,236,025
Claims Incurred	(5,733,524)	(4,870,410)	(4,089,232)	(3,592,818)
Commission Expenses	(485,323)	(1,053,299)	(1,088,644)	(933,627)
Management Expenses	(2,507,803)	2,307,020	(2,146,961)	(2,129,210)
Increase in Life Fund Before Taxation	7,887,842	7,728,350	6,767,312	3,173,803
Taxation	(899,025)	(897,006)	(726,442)	(813,114)
Increase in Life Fund	6,988,817	6,831,344	6,040,870	2,360,689

SLASs					
2010	2009	2008	2007	2006	2005
Rs. '000	Rs. '000	Rs. '000	Rs. '000	Rs. '000	Rs. '000
9,266,637	8,764,542	9,140,844	8,845,352	6,643,634	6,621,006
6,034,185	6,592,541	6,478,099	5,262,586	4,031,808	4,280,599
(2,885,793)	(5,379,207)	(4,819,146)	(3,866,706)	(3,509,847)	(2,313,991)
(1,917,877)	(2,188,042)	2,022,975	(2,217,357)	(1,443,369)	(1,467,795)
10,112,693	1,940,038	1,202,306	974,643	1,475,458	715,804
11,343,207	965,330	838,283	153,167	554,051	1,214,617
(843,740)	(233,096)	(254,598)	83,336	5,652	(134,189)
10,499,467	732,232	583,685	236,503	559,703	1,080,428
6,009,859	4,819,860	4,497,919	4,477,632	3,923,374	3,550,511
5,945,561	4,769,590	4,381,490	4,356,180	3,848,363	3,438,723
13,026,350	7,227,092	5,398,818	4,480,740	3,908,694	3,267,900
(4,957,675)	(3,831,985)	(3,289,846)	(2,502,466)	(2,188,818)	(2,064,039)
(648,033)	(547,848)	(552,689)	(492,431)	(395,926)	(346,135)
(1,483,218)	(1,317,279)	(2,037,946)	(1,679,168)	(1,294,991)	(1,033,132)
11,882,985	6,299,570	3,899,827	4,162,855	3,877,322	3,263,316
(1,151,175)	(1,075,883)	(793,213)	(634,884)	(556,641)	(312,587)
10,731,810	5,223,687	3,106,614	3,527,971	3,320,681	2,950,729

	SLFRSs/LKASs			
	2014	2013	2012	2011
	Rs. '000	Rs. '000	Restated Rs. '000	Restated Rs. '000
Total Business				
Revenue	32,163,061	31,526,665	25,644,316	17,207,927
Gross Written Premium	20,665,987	21,350,869	20,172,624	18,220,673
Net Earned Premiums	17,804,907	17,805,056	16,768,442	14,422,101
Benefits, Losses and Expenses	(18,928,978)	(16,467,961)	(15,625,260)	(7,718,624)
Investment and Other Income	11,497,074	10,175,796	8,875,874	2,785,827
Operating and Administrative Expenses	(6,970,498)	(6,211,321)	(4,155,798)	(4,054,218)
Profit Before Taxation	4,373,139	6,354,869	5,863,255	5,435,086
Taxation	(1,116,126)	(1,700,039)	(1,627,413)	(1,220,547)
Profit After Taxation	3,257,014	4,654,830	4,235,842	4,214,539

SLASs					
2010	2009	2008	2007	2006	2005
Rs. '000	Rs. '000	Rs. '000	Rs. '000	Rs. '000	Rs. '000
43,777,495	22,306,632	17,460,713	15,074,148	13,264,324	11,703,025
15,239,001	13,584,399	13,638,763	13,322,984	10,567,008	10,171,517
11,942,251	11,362,130	10,859,589	9,618,766	7,880,171	7,719,321
(22,203,564)	(16,673,008)	(13,450,368)	(12,537,143)	(10,683,110)	(8,867,951)
28,538,494	10,945,554	6,601,124	5,455,383	5,384,152	3,983,705
(3,185,346)	(2,776,014)	(2,248,664)	(1,748,956)	(1,470,521)	(1,307,872)
15,130,395	2,851,431	1,631,497	788,051	1,110,692	1,527,203
(1,860,560)	(1,322,893)	(1,047,811)	(551,548)	(550,989)	(446,776)
13,269,836	1,528,566	583,685	236,503	559,703	1,080,427

8.3.2 STATEMENT OF FINANCIAL POSITION

	2014	SLFRSs/LKASs		
		2013	2012	2011
	Rs. '000	Rs. '000	Restated Rs. '000	Restated Rs. '000
Assets				
Property, Plant & Equipment	37,143,633	32,337,013	27,909,258	16,531,061
Investments	116,624,657	94,771,272	88,784,965	93,335,443
Other Assets	41,314,624	45,113,975	36,136,924	21,494,742
Total Assets	195,082,914	172,222,260	152,831,147	131,361,246
Equity and Liabilities				
Share Capital	6,000,000	6,000,000	6,000,000	6,000,000
Capital Reserve	9,346,422	8,738,238	9,161,368	4,638,021
General Reserve	643,442	643,442	643,442	643,442
Available-For-Sale Reserve	26,525,252	15,364,711	12,521,041	13,190,776
Revenue Reserve	36,856,370	32,635,520	25,022,161	19,046,744
Non-Controlling Interest	7,246,077	7,054,574	1,647,284	1,522,687
Total Capital and Reserves	86,596,534	70,453,741	54,995,296	45,041,670
Liabilities				
Insurance Provision – Long Term	77,254,496	69,079,061	62,526,048	58,494,522
Insurance Provision – Non-Life	13,195,783	13,288,956	14,297,803	13,132,830
Other Liabilities	18,036,101	19,400,502	21,012,000	14,692,223
Total Liabilities	108,486,380	101,768,519	97,835,851	86,319,575
Total Equity and Liabilities	195,082,914	172,222,260	152,831,147	131,361,245

SLASs					
2010 Restated Rs. '000	2009 Rs. '000	2008 Rs. '000	2007 Rs. '000	2006 Rs. '000	2005 Rs. '000
15,955,573	6,926,428	4,748,020	3,785,584	3,826,497	3,118,738
98,061,820	56,626,575	43,191,685	40,303,650	32,919,361	21,532,711
25,282,852	11,545,918	16,818,869	14,008,393	15,813,698	21,905,509
139,300,245	75,098,921	64,758,574	58,097,627	52,559,556	46,556,958
6,000,000	6,000,000	6,000,000	6,000,000	6,000,000	6,000,000
5,359,282	1,457,507	1,448,135	536,339	536,339	
643,442	643,442	601,342	601,342	601,342	601,342
25,704,419	-	-	-	-	-
20,990,007	3,481,934	1,487,222	1,095,375	1,258,871	1,099,169
2,041,104	911,246	-	-	-	-
60,738,254	12,494,129	9,536,699	8,233,056	8,396,552	7,700,511
52,573,602	43,956,012	39,470,887	35,654,300	31,947,127	28,496,288
11,772,953	11,804,983	10,636,192	9,887,724	8,342,175	6,255,057
14,215,436	6,843,796	5,114,796	4,322,547	35,820,829	3,912,201
78,561,991	62,604,792	55,221,875	49,864,571	44,163,004	38,856,447
139,300,245	75,098,921	64,758,574	58,097,627	52,559,556	46,556,958

	2014	SLFRSs/LKASs		
		2013	2012	2011
	Rs. '000	Rs. '000	Restated Rs. '000	Restated Rs. '000
Long Term – Supplemental				
Assets				
Property, Plant & Equipment	42,172	55,969	57,012	46,553
Investments	92,914,463	73,643,020	73,029,822	72,799,868
Other Assets	5,640,884	12,553,679	9,497,112	4,850,532
Total Assets	98,597,519	86,196,699	82,583,945	77,696,953
Liabilities				
Long-Term Insurance Fund	75,368,621	69,079,806	62,526,048	58,494,521
Other Liabilities	5,764,890	2,743,847	2,510,653	2,575,067
Equity Attributable to Shareholders				
Capital Reserve	27,877	40,892	40,892	16,106
Revenue Reserve	17,436,131	14,332,153	17,506,352	16,611,259
Total Liabilities	98,597,519	86,196,699	82,583,945	77,696,953

SLASs					
2010 Restated Rs. '000	2009 Rs. '000	2008 Rs. '000	2007 Rs. '000	2006 Rs. '000	2005 Rs. '000
53,343	63,305	107,748	134,488	140,960	151,205
74,540,011	42,219,092	30,815,851	28,201,706	21,325,082	18,113,080
11,865,314	6,216,560	11,054,551	9,079,332	11,993,334	11,876,465
86,458,668	48,498,957	41,978,150	37,415,526	33,459,376	30,140,750
52,573,602	43,956,013	39,470,892	35,654,300	31,947,127	28,496,288
2,589,100	2,978,417	2,516,258	1,761,226	1,512,249	1,644,462
16,106	9,372	-	-	-	-
31,279,861	1,555,156	-	-	-	-
86,458,669	48,498,957	41,987,150	37,415,526	33,459,376	30,140,750

8.4.0 GLOSSARY

This Glossary was developed basically based on the definitions given in the Statement of Recommended Practice for Insurance Contracts issued by The Institute of Chartered Accountants of Sri Lanka.

Actuary

Actuary is a person who provides solutions to insurance-related problems using mathematics, statistics and financial theory. The actuary will study significant data such as mortality, sickness, injury and disability rates and use that information to assist those involved with insurance.

Acquisition Expenses

All expenses mainly incurred in acquiring new business premiums and conservation of renewal business. Broad in scope, it includes cost of soliciting business, issuance of policies, collection of premiums, agents' compensation, field supervision, advertising and any other expenses reasonably attributable to acquisition and conservation of written premiums.

Admissible Assets

Assets that may be included in determining an insurer's statutory solvency. Such assets are specified under the rules made by the Insurance Board of Sri Lanka under the Regulation of Insurance Industry Act No. 43 of 2000.

Approved Assets

Assets that represent the technical reserves and the long-term insurance fund as per the Determination made under the Regulation of Insurance Industry Act No. 43 of 2000.

Bancassurance

A partnership between a bank and an insurance company whereby the insurance company uses the bank sales channel to sell its insurance products.

Beneficiary

In life insurance business, the person named in the policy by the policyholder (insured) to whom the insurance money is paid at the death of the insured.

Claim

The amount payable under a contract of insurance arising from the concurrence of an insured event.

Claims Incurred

A claim is incurred when the event giving rise to the claim occurs. Claims incurred include paid claims and movements in outstanding claims.

Claims Incurred but not Reported

Claims arising out of events which have occurred by the reporting date, but have not reported to the insurer at that date.

Claims Outstanding – Non-Life Insurance Business

The amount provided to cover the estimated ultimate cost of settling claims arising out of events which have occurred by the reporting date including IBNR claims and claims handling expenses, less amounts already paid in respect of those claims.

Claims Outstanding – Life Insurance Business

The amount provided to cover the estimated ultimate cost of settling claims arising out of events which have been notified by the reporting date being the sums due to beneficiaries together with claims handling expenses, less amounts already paid in respect of those claims.

Co-Insurance

An arrangement whereby two or more insurance undertakings enter into a single contract with the insured to cover a risk in agreed proportions at a specified premium.

Commissions

A payment made to a broker or a sales agent in return for selling and servicing an insurer's products.

Deferred Acquisition Costs – Non-Life Insurance Business

Under the annual basis of accounting, acquisition costs relating to the unexpired period of risk of contracts in force at the reporting date which are carried forward from one accounting period to subsequent accounting periods.

Deferred Acquisition Costs – Life Insurance Business

Acquisition costs relating to contracts in force at the reporting date which are carried forward from one accounting period at subsequent accounting periods in the expectation that they will be recoverable out of future margins within insurance contracts after providing for contractual liabilities.

8.5.0 BRANCH OFFICES

- | | | | |
|---|---|--|---|
| <p>1. Akkaraipattu
143, Main Street
Akkaraipattu - 2
Tel: 067-2279627</p> | <p>11. Balangoda
60/1/1, Barns Ratwatte
Mawatha
Tel: 045-2287670
045-5678445</p> | <p>22. Chilaw
431/1, Kurunegala Road
Tel: 032-2222371
032-5671749</p> | <p>32. Embilipitiya
67, Pallegama
Tel: 047-2230389
047-5672205</p> |
| <p>2. Akuressa
40 2/1, Matara Road
Tel: 041-2283590
041-5674482</p> | <p>12. Bambalapitiya
316, Galle Road,
Tel: 011-5632790
011-5673296</p> | <p>23. City Office
288, Union Place,
Colombo 02
Tel: 011-2357562
011-5677136</p> | <p>33. Fort
96/1-6B, Front Street,
Consistory Building,
1st Floor, Colombo 11
Tel: 011-5741820</p> |
| <p>3. Ambalangoda
299, Wickramasuriya Road
Tel: 091-2258339
091-5678298</p> | <p>13. Bandaragama
72, Jayakody Building,
Horana Road
Tel: 038-2293940</p> | <p>24. Dambulla
642, Anuradhapura Road
Tel: 066-2284616
066-5671624</p> | <p>34. Galewela
59-A, Kurunegala Road
Tel: 066-2289285,
066-5671651</p> |
| <p>4. Ambalantota
156/8, Tissa Road
Tel: 047-2223235
047-5670906</p> | <p>14. Bandarawela
250/1/A,
Badulla Road
Tel: 057-2223526
057-5670703</p> | <p>25. Dehiattakandiya
256, Mahaweli Uyana
Tel: 027-2250318</p> | <p>35. Galgamuwa
121, Anuradhapura Road,
Tel: 037-2254141
037-5673406</p> |
| <p>5. Ampara
01, Inginiyagala Road
Tel: 063-2222073
063-5670307</p> | <p>15. Batticaloa
30, Pioneer Road
Tel: 065-2224470</p> | <p>26. Dehiwala
121 1/1,
Ramanayaka Auto Mobile
(Pvt) Ltd.
121 1/1, Galle Road
Tel: 011-2713702
011-5744962</p> | <p>36. Galle
50 A, Havelock Road
Tel: 091-2234531
091-2224029</p> |
| <p>6. Anamaduwa
70, Puttalam Road
Tel: 032-2263033
032-5675227</p> | <p>16. Battaramulla
119, Pannipitiya Road
Tel: 011-2866357
011-5634629</p> | <p>27. Deniyaya
122, Rathna Mahal,
Main Street
Tel: 041-2273565
041-5674483</p> | <p>37. Gampaha
14, Holy Cross Road
Tel: 033-2222676
033-5675786</p> |
| <p>7. Anuradhapura
248, Maithripala
Senanayaka Mawatha
Tel: 025-2222167</p> | <p>17. Beliatta
74, Tangalle Road
Tel: 047-2243211
047-5670908</p> | <p>28. Dikwella
95, Matara Road
Tel: 041-2255630
041-5674476</p> | <p>38. Gampola
176/A, Kandy Road
Tel: 081-2351709
081-5675128</p> |
| <p>8. Avissawella
77, Ratnapura Road
Tel: 036-2222311
036-5672324</p> | <p>18. Beruwala
167/1, Galle Road
Tel: 034-2276409
034-5674655</p> | <p>29. Digana
42, Gonawala Road,
Digana, Rajawella
Tel: 081-5630744,
081-2376814</p> | <p>39. Giriulla
90, Negombo Road
Tel: 037-2288304
037-5673405</p> |
| <p>9. Baddegama
60/1/1, Galle Road
Tel: 091-2292303
091-5624502</p> | <p>19. Bibile
Opposite R.S. Office
Tel: 055-5675673</p> | <p>30. Eheliyagoda
281, Fancy Mahal Building,
Main Street
Tel: 036-2259014</p> | <p>40. Hakmana
95, Kosgahawatte,
Matara Road
Tel: 041-5670600</p> |
| <p>10. Badulla
14, R.H. Gunawardena
Mawatha
Tel: 055-2230972
055-2230972</p> | <p>20. Chankanai
45, Ponnalai Road
(Main Street)
Tel: 021-2250462</p> | <p>31. Elpitiya
1st Floor,
Royal Building,
Ambalangoda Road
Tel: 091-2291365,
091-5673672</p> | <p>41. Hatton
175/1/1, Dambulla Road
Tel: 051-2222196
051-5670202</p> |

- 42. Hambantota**
59, Main Street
Tel: 047-2222572
- 43. Hingurakgod**
59, 3rd Cross Street
Tel: 027-2246345
027-5672038
- 44. Homagama**
64, High Level Road
Tel: 011-2893426
011-5634670
- 45. Horana**
50/09/C,
Graceland Circular Road
Tel: 034-2261351
034-5674512
- 46. Horowpothana**
Rest House Junction
Tel: 025-2278600
- 47. Ja-Ela**
205/1/1, Negombo Road
Tel: 011-2233169
011-5639270
- 48. Jaffna**
571, Hospital Road
Tel: 021-2222023
- 49. Kadawatha**
151/5, Kandy Road
Tel: 011-2921567
- 50. Kaduruwela**
399, Main Street
Tel: 027-2222954
027-5672041
- 51. Kaduwela**
482/8, Colombo Road
Tel: 011-2579976
011-5628269
- 52. Kahawatta**
46/1A, Walauwatta Road
Tel: 045-2270160
045-5674248
- 53. Kalawana**
56, Sampath Bank Building,
Matugama Road, Manana
Tel: 045-2255930
- 54. Kalmunai**
102/1, Police Station Road
Tel: 067-2229912
067-5670168
- 55. Kalutara**
55 1/1, Paranagama
Building, Galle Road
Tel: 034-2222474
034-5674535
034-5620770
- 56. Kandana**
54, Negombo Road
Tel: 011-2228848
011-5649536
- 57. Kandy - 1**
25, Hill Street
Tel: 081-2234954
081-2228172
081-2234296
081-2224036
- 58. Kandy - FBD**
No. 6, Wadugodapitiya Road
Tel: 081-5627274
- 59. Kandy - 2**
06, Wadugodapitiya Street
Tel: 081-2224246
- 60. Kantale**
62/P, Main Street
Tel: 026-2234043
- 61. Katunayaka -EPZ**
Unit - No. 03, BOI Plaza
Building, EPZ Katunayaka
Tel: 011-2251394
- 62. Kegalle**
450 A, Meepitiya
Tel: 035-2222531
- 63. Kekirawa**
81, Thalawa Road
Tel: 025-2264573
025-5673430
- 64. Kilinochchi**
31, A-09 Road,
Karadippokka
Tel: 021-2280031
- 65. Kiribathgoda**
101/1, Galaha Junction,
Kandy Road
Tel: 011-5554485
011-5635483
- 66. Kirulapone**
88, 1/1, 1st Floor,
High Level Road
Tel: 011-2514348
011-5649541
- 67. Kochchikade**
96, Chilaw Road
Tel: 031-2274626
031-5677135
- 68. Kotahena**
4th Floor, 178, Gold Tower,
George R. De Silva Mawatha
Tel: 011-5673345
- 69. Kuliypatiya**
74/A, Hettipola Road
Tel: 037-2281304
037-5673401
- 70. Kurunegala**
16/1, Dambulla Road
Tel: 037-2222376
037-2227433
- 71. Kurunegala City**
63/1, Rajapihilla Road
Tel: 037-2234176
- 72. Maharagama**
128, Opposite Elhena Road
Tel: 011-2843563
011-5635465
- 73. Mahiyanganaya**
14, Samanala Building,
1st Floor, Kandy Road
Tel: 055-2257179
055-5670344
- 74. Malabe**
821/3C, New Kandy Road
Tel: 011-2762312
011-5651612
- 75. Mannar**
Station Road
(Opposite Pakiya Studio)
Tel: 023-2223236
- 76. Marawila**
83A, Negombo Road
Tel: 032-2254297
032-5672090
- 77. Matale**
134, Dharmapala Mawatha
Tel: 066-2233989
066-5671653
- 78. Matara**
5A, Hakmana Road
Tel: 041-2227962
041-2222352
- 79. Matara - FBD**
5A, Hakmana Road
Tel: 041-2222227
041-5620528
- 80. Mathugama**
79/1/1, Kalutara Road
Tel: 034-2247510
034-5674654
- 81. Mawanella**
238 1/1, Kandy Road
Tel: 035-2249335,
035-5672981
- 82. Melsiripura**
197/1, Dambulla Road,
Melsiripura
Tel: 037-2250459
- 83. Minuwangoda**
21/B, M.P. De Z.
Siriwardhana Mawatha
Tel: 011-2280870
011-5667822
- 84. Monaragala**
114/1, Wellaway Road
Tel: 055-2276145,
055-5670525
- 85. Moratuwa**
710, Idama, Galle Road
Tel: 011-5554451
011-5644634
- 86. Mullaitivu**
Main Street
Tel: 021-2290089

- 87. Narammala**
159/A, Supper City Building, U.B. Wijekoon Mawatha, Kurunegala Road
Tel: 037-2248920
- 88. Nawalapitiya**
79, Kotmale Road
Tel: 054-2222019
- 89. Negombo**
20, Rajapaksha Broadway
Tel: 031-2231374
031-2235235
- 90. Nelliadi**
Main Street
(Opposite People's Bank)
Tel: 021-2264686
- 91. Nikaweratiya**
196, Puttalam Road
Tel: 037-2260279
037-5673441
- 92. Nittambuwa**
New Super Market Complex
Tel: 033-2289709
033-5671351
- 93. Nugegoda**
Sausiri Building, 4th Floor, High Level Road
Tel: 011-2817739,
011-2826364
011-5635464
- 94. Nuwara Eliya**
60/1, Park Street
Tel: 052-2222759
052-5670529
- 95. Panadura**
534, Galle Road
Tel: 038-2234736
038-5671547
- 96. Pilimathalawa**
211/C, Colombo Road
Tel: 081-2575444
081-5630070
- 97. Piliyandala**
34, Vidyala Mawatha
Tel: 011-2613976
- 98. Pitakotte**
463, Kotte Road
Tel: 011-2866755
- 99. Puttalam**
80, Kurunegala Road
Tel: 032-2265324,
032-5672749
- 100. Ratmalana**
143/2/4, Mount City, Galle Road
Tel: 011-2715992
011-5635475
- 101. Ratnapura**
258, Main Street
Tel: 045- 2222433
- 102. Rikillagaskada**
68, Ragala Road
Tel: 081-2365279
081-5674793
- 103. Talgaswala**
New Town
Tel: 091-5676789
- 104. Thambuttegama**
137, Rajina Junction, Kurunegala Road
Tel: 025-2275088
- 105. Thangalle**
12, Indipokunagoda Road,
Tel: 047-5676144
- 106. Tissamaharama**
211B, Kachcheriyagama
Tel: 047-2237152
047-5670905
- 107. Trincomalee**
46, Main Street
Tel: 026-2222434
026-5675025
- 108. Udugama**
Pasans New Building, Mavi Dola, Bar Junction
Tel: 091-2285097
091-5674987
- 109. Vavuniya**
119/1, Kandy Road
Tel: 024-2222380
024-5670021
- 110. Veyangoda**
166, Negombo Road
Tel: 033-2288027
033-5676037
- 111. Warakapola**
459, Main Street
Tel: 035-2267747
035-5671938
- 112. Wariyapola**
29/1, Adhikari Mawatha
Tel: 037-2267451
037-5673407
- 113. Wattala**
396, Negombo Road
Tel: 011-5355531
011-5355532
- 114. Weligama**
352/2,
Galle - Matara Middle Road
Tel: 041-2250647
041-5673167
- 115. Welimada**
15 2/1, 2nd Floor, New Shopping Complex, Badulla Road,
Tel: 057-2245174
057-5670702
- 116. Wellawaya**
145/1/1, Hambantota Road
Tel: 055-2274874
055-5673345
- 117. Wennappuwa**
236/3/A, Chilaw Road
Tel: 031-2253319,
031-5672447
- 4. Hikkaduwa**
231, Galle Road
Tel: 091-2277124
- 5. Imaduwa**
New Shopping Complex, Main Street
Tel: 091-5678781
- 6. Kamburupitiya**
154 A/1, Matara Road
Tel: 041-5670291
- 7. Karapitiya**
Hirimbura Road
Tel: 091-5620286
091-224719
- 8. Kirindiwela**
27/8/1, Colombo Road
Tel: 033-5621192
- 9. Medirigiriya**
Main Street
Tel: 071-8600247
- 10. Middeniya**
Walasmulla Road
Tel: 047-5670437
- 11. Mirigama**
Opposite Police Station
Tel: 033-2273441
- 12. Narahenpita**
Department of Motor Traffic, P.O. Box 533, Elvitigala Mawatha Colombo 05
- 13. Pugoda**
40/1, Kospitiyana
Tel: 033-5621223
- 14. Thanipolgaha**
97/1B, H.K. Edmond Mawatha
Tel: 091-2227041
- 15. Urubokka**
2nd Floor, Shopping Complex, Main Street
Tel: 041-5670420
- CUSTOMER SERVICE CENTRES - 15**
- 1. Divulapitiya**
56, Kurunegala Road
Tel: 031-5674774
- 2. Ganemulla**
187/A/8, Main Street
Tel: 033-5621208
- 3. Habaraduwa**
10/1, Matara Road
Tel: 091-2282605

8.6.0 CORPORATE INFORMATION

NAME OF THE COMPANY AND REGISTERED OFFICE

Sri Lanka Insurance Corporation Ltd.
No. 21, Vauxhall Street, Colombo 2.
Tel: +94 11 2357457
Fax: +94 11 2447742
Web: www.srilankainsurance.com

COMPANY REGISTRATION NUMBER

Company was incorporated on 3rd February 1993 under the Companies Act No. 17 of 1982 bearing No. N(PBS/CGB)/159 and re-registered under the Companies Act No. 07 of 2007 on 17th April 2008 bearing No. PB 289.

BOARD OF DIRECTORS

The following Board members ceased to be effective w.e.f. 20th January 2015:

Mr. H.K. Upali Dharmadasa
Mr. P. Kudabalage
Mr. H. Isuru Balapatabendi
Mr. S.V.R. Samarasinghe
Mr. Nayana D.P. Dehigama
Ms. K.M.A.N. Daulagala

The following members were appointed w.e.f. 20th January 2015:

Prof. L.G. Chandrasena
Mr. H. Imal S. Fonseka
Mr. P. Algama

The following members were appointed w.e.f. 9th February 2015:

Mr. Hemaka D.S. Amarasuriya
Mr. T.M.R. Bangsa Jayah
Mr. P.P.J. Perera

LEGAL FORM

Sri Lanka Insurance Corporation Ltd. was established under the provisions of Insurance Corporation Act No. 2 of 1961 as a State-Owned Corporation. In 1993, the Corporation was converted to a fully Government-owned limited liability company of which the sole shareholder of 100% shares was the Secretary to the Treasury, under the Conversion of Public Corporations or Government-owned Business Undertakings into Public Companies Act No. 23 of 1987. Under the privatisation programme of the Government, the Company was privatised in 2003 and was under the private management for a brief period of six years. The Corporation was re-registered under the Companies Act No. 07 of 2007. Pursuant to the Supreme Court Judgment on 04th June 2009, annulling the privatisation, 99.97% shares are vested with the Secretary to the Treasury on behalf of the Government of Sri Lanka.

TAX PAYER IDENTIFICATION NUMBER (TIN)

294001590

VAT REGISTRATION NUMBER

294001590-7000

COMPANY SECRETARIES

Varners International (Pvt) Ltd.
Level 14, West Tower,
World Trade Center,
Echelon Square,
Colombo 01.

SUBSIDIARIES

Management Services Rakshana (Pvt) Ltd.
The Lanka Hospitals Corporation PLC
Litro Gas Lanka Ltd.
Litro Gas Terminal Lanka (Pvt) Ltd.
Canwill Holdings (Pvt) Ltd.
Canowin Hotels and Spas (Pvt) Ltd. (Formerly known as Sri Lanka Insurance Resorts and Spas (Pvt) Ltd.)

SUB-SUBSIDIARIES

Lanka Hospitals Diagnostics (Pvt) Ltd.
Helanco Hotels & Spa (Pvt) Ltd.
Sinolanka Hotels & Spa (Pvt) Ltd.

AUDITORS

KPMG (Chartered Accountants)
32A, Sir Mohamed Macan Marker Mawatha,
Colombo 03.

BANKERS

People's Bank
Commercial Bank of Ceylon PLC
Nations Trust Bank
Development Finance Corporation of Ceylon (DFCC Bank)
Hatton National Bank PLC
Hongkong and Shanghai Banking Corporation Ltd. (HSBC)

Seylan Bank PLC
Sampath Bank PLC
Standard Chartered Bank
Bank of Ceylon
National Savings Bank
Citi Bank
Deutsche Bank

In addition to above operational banks, SLIC has made investments in the following banks:

Rural Development Bank
Citizen Development Bank PLC
Pan Asia Bank PLC
National Development Bank PLC
Housing Development Finance Corporation Bank of Sri Lanka

ACTUARY - LIFE

Messrs Towers Watson Singapore Pte Ltd.
63, Chulia Street
#09-01 OCBC Centre East
Singapore 049514

ACTUARY - NON-LIFE

Messrs NMG Financial Services Consulting
65, Chulia Street
#37-07/08 OCBC Centre
Singapore 049513

8.7.0 NOTICE OF ANNUAL GENERAL MEETING

NOTICE IS HEREBY GIVEN that the ANNUAL GENERAL MEETING of SRI LANKA INSURANCE CORPORATION LTD. will be held at the Auditorium of the Company at its Registered Office at No. 21, Vauxhall Street, Colombo 02 on Tuesday, 30th June 2015 at 10.00 a.m. for the following purposes:

1. To receive and consider the Report of the Directors and the Financial Statements for the year ended 31st December 2014 and the Report of the Auditors thereon.
2. To declare a First and Final Dividend of Rs. 3.34 per share (Totalling a sum of Rs. 2,003,142,288/-) for the year ended 31st December 2014, as recommended by the Directors.
3. To elect Mr. Hemaka D.S. Amarasuriya, Director who retires in terms of Article 98 of the Articles of Association of the Company and to consider and, if thought fit, to pass the following Ordinary Resolution pertaining to the appointment of Mr. Hemaka D.S. Amarasuriya, as a Director of the Company:

That the age limit of seventy years stipulated in Section 210 of the Companies Act No. 07 of 2007 shall not apply to Mr. Hemaka D.S. Amarasuriya, who at the date of this resolution, is 71 years of age (having reached 70 years of age on 19th November 2013), and that Mr. Hemaka D.S. Amarasuriya be and is hereby appointed as a Director of Sri Lanka Insurance Corporation Ltd., in terms of Section 211 of the Companies Act No. 07 of 2007.

4. To elect Mr. T.M.R. Bangsa Jayah, Director who retires in terms of Article 98 of the Articles of Association of the Company.
5. To elect Mr. P.P.J. Perera, Director who retires in terms of Article 98 of the Articles of Association of the Company.
6. To elect Prof. L.G. Chandrasena, Director who retires in terms of Article 98 of the Articles of Association of the Company.
7. To elect Mr. H. Imal S. Fonseka, Director who retires in terms of Article 98 of the Articles of Association of the Company.

8. To elect Mr. P. Algama, Director who retires in terms of Article 98 of the Articles of Association of the Company.
9. To reappoint Messrs KPMG, the retiring Auditors subject to the appointment of a new Audit Partner of the said Firm, in line with the Code of Best Practice on Corporate Governance and to authorise the Directors to determine their remuneration.
10. To authorise the Directors to determine donations for the year 2015 and upto the date of the next Annual General Meeting.
11. Any other business of which due notice has been given.

By Order of the Board,



Varners International (Pvt) Ltd.

Level 14, West Tower,
World Trade Center,
Echelon Square,
Colombo 01.

1st June 2015
Colombo

FORM OF PROXY

I/We*
of
being a member/members* of Sri Lanka Insurance Corporation Ltd. hereby appoint:
.....
of of failing him/her*

Mr. Hemaka D.S. Amarasuriya	of Colombo or failing him
Mr. T.M.R. Bangsa Jayah	of Colombo or failing him
Mr. P.P.J. Perera	of Colombo or failing him
Prof. L.G. Chandrasena	of Colombo or failing him
Mr. H. Imal S. Fonseka	of Colombo or failing him
Mr. P. Algama	of Colombo

As my/our* proxy to represent me/us* and to vote as indicated hereunder for me/us* and on my/our* behalf at the Forty-First Annual General Meeting of the Company to be held on 30th June 2015 and at every poll which may be taken in consequence of the aforesaid meeting and at any adjournment thereof.

RESOLUTIONS

- | | | |
|---|--------------------------|--------------------------|
| 1. To receive and adopt the Report of the Directors and the Financial Statements for the year ended 31st December 2014 with the Report of the Auditors thereon. | <input type="checkbox"/> | <input type="checkbox"/> |
| 2. To declare a First and Final Dividend of Rs. 3.34 per Share (Totalling a sum of Rs. 2,003,142,288/-) for the year ended 31st December, 2014 as recommended by the Directors. | <input type="checkbox"/> | <input type="checkbox"/> |
| 3. To reappoint Mr. Hemaka D.S. Amarasuriya, Director who retires in terms of Article 98 of the Articles of Association and Section 210 of the Companies Act as a Director of the Company and to pass the Ordinary Resolution set out in the Notice specifically declaring that the age limit of 70 years shall not apply to him. | <input type="checkbox"/> | <input type="checkbox"/> |
| 4. To elect Mr. T.M.R. Bangsa Jayah, Director who retires in terms of Article 98 of the Articles of Association of the Company. | <input type="checkbox"/> | <input type="checkbox"/> |
| 5. To elect Mr. P.P.J. Perera, Director who retires in terms of Article 98 of the Articles of Association of the Company. | <input type="checkbox"/> | <input type="checkbox"/> |
| 6. To elect Prof. L.G. Chandrasena, Director who retires in terms of Article 98 of the Articles of Association of the Company. | <input type="checkbox"/> | <input type="checkbox"/> |
| 7. To elect Mr. H. Imal S. Fonseka, Director who retires in terms of Article 98 of the Articles of Association of the Company. | <input type="checkbox"/> | <input type="checkbox"/> |
| 8. To elect Mr. P. Algama, Director who retires in terms of Article 98 of the Articles of Association of the Company. | <input type="checkbox"/> | <input type="checkbox"/> |
| 9. To reappoint Messrs KPMG, the retiring Auditors, subject to the appointment of a new Audit Partner of the said Firm, in line with the Code of Best Practice on Corporate Governance, and to authorise the Directors to determine their remuneration. | <input type="checkbox"/> | <input type="checkbox"/> |
| 10. To authorise the Directors to determine donations for the year 2015 and upto the date of the next Annual General Meeting. | <input type="checkbox"/> | <input type="checkbox"/> |

Signed this day of 2015.

.....
Signature of Shareholder/s

*Please delete the inappropriate words.

NOTE:

1. *A member entitled to attend and vote at the meeting is entitled to appoint a proxy to attend and vote instead of him.*
2. *A proxy need not be a member of the Company.*
3. *The completed Form of Proxy must be deposited at the Registered Office of the Company at the Company Secretariat, Sri Lanka Insurance Corporation Ltd., 8th Floor, No. 21, Vauxhall Street, Colombo 02, not less than 48 hours before the time fixed for the meeting.*







www.srilankainsurance.com